

INVITATION TO BID
TRUCKEE MEADOWS WATER AUTHORITY
INNOVATION WELL AND ARMY AVIATION WELL DRILLING, CONSTRUCTION,
DEVELOPMENT AND TESTING
TWMA CAPITAL PROJECT NO.: 15-0018
PUBLIC WORKS CONTRACT NO. PWP #WA-2015-235

RANGE FOR ENGINEER'S ESTIMATE: \$1,224,100.00 - \$1,496,100.00

PROJECT SCOPE: Truckee Meadows Water Authority (TMWA) is accepting sealed bids for all labor, materials, equipment, and incidentals required for the Innovation Well and Army Aviation Well, Drilling, Construction, Development and Testing. The two work sites are located on TMWA property at 6995 Longley Lane, Reno, Nevada, and 20100 Army Aviation Drive, Reno, Nevada. The Work consists of completing all activities to drill, construct, develop, and test two production wells at each project site.

TMWA will provide coordinates for the well head locations.

Project Control provided by TMWA.

MANDATORY PRE-BID CONFERENCE: NOT REQUIRED FOR THIS PROJECT.

BID DOCUMENTS: All bid documents may be downloaded from TMWA's website at http://tmwa.com/about_us/doingbusinesswithtmwa

BID SUBMITTAL: Sealed bids must be submitted to TMWA by mail to P.O. Box 30013, Reno, Nevada 89520-3013 or in person to 1355 Capital Boulevard, Reno, NV 89502, and must be **RECEIVED BY TMWA NOT LATER THAN 11:00 A.M. on July 31, 2015**. Bids received after the date and time set for receipt will be **REJECTED**.

BID OPENING: **July 31, 2015, at 11:05 a.m.** at the TMWA Conference Room, 1355 Capital Blvd., Reno, NV 89502. TMWA reserves the right to reject any or all bids, including without limitation the right to reject any or all nonconforming, non-responsive, unbalanced, or conditional bids, and to reject the bid of any bidder if TMWA believes that it would not be in the best interest of TMWA to make an award to that bidder. TMWA also reserves the right to waive informalities. Bids will be evaluated as prescribed in Nevada Revised Statute 338.147.

ANTICIPATED START DATE: To be Determined on or Before October 1, 2015

COMPLETION DEADLINE: Eighty-Four (84) days following Notice to Proceed.

PLANS AND SPECIFICATIONS:

Not Applicable

Bidders are to complete all Bid Submittal Forms, contained on pages 2-18 in the Bid Proposal Form Section of the Bid Documents. The complete Contract Documents must be submitted to comprise a responsive and responsible bid. Each bid shall be accompanied by a certified or cashier's check or bid bond in the amount of not less than five percent of the amount bid in the proposal. Addenda, if any, shall be posted on the TMWA web-site at:

http://www.tmwa.com/about_us/doingbusinesswithtmwa/

It is each bidder's sole responsibility to ensure that they have received all addenda prior to submission of their bid.

QUESTIONS: Questions may be submitted in writing to the Contract Administrator up to three (3) business days before Bid Opening.

Maria I. Dufur, Contract Administrator
Truckee Meadows Water Authority
1355 Capital Boulevard
Reno, NV 89502
(775) 834-8056
Fax (775) 834-8153: e-mail: mdufur@tmwa.com

BIDDING PROCEDURES TABLE OF CONTENTS

Section 1

Invitation to Bid

Table of Contents

Instructions to Bidders

Bid Proposal Forms

Bid Bond

Bid Schedule

Debarment Certification

List of Subcontractors

Acknowledgement and Execution Page

Prevailing Wage Attachment (Copy of Current Prevailing Wage Rates in Washoe County)

Section 2

Construction Contract

Contract ("Sample")

Performance Bond

Labor and Material Payment Bond

General Conditions

Supplementary Conditions

Special Provisions

TMWA Standard Construction Standards

(Incorporated by reference but not attached)

Portions of the Standard Specifications for Public Works Construction (2012 Orange Book)

(Portions Incorporated by reference pursuant to General Conditions but not attached)

Section 3

Water Supply Wells Drilling and Construction

INSTRUCTIONS TO BIDDERS

I. BIDDING PROCEDURES

A. Pre-bid Conference – NOT REQUIRED FOR THIS PROJECT.

B. Designated Contacts

The designated contact for questions pertaining to the Contract Documents, Specifications and/or Drawings is the designated Contract Administrator. All questions should be submitted in writing, and will receive a written response from the Contract Administrator.

Maria I. Dufur
Truckee Meadows Water Authority
P.O. Box 30013
Reno, NV 89502
775-834-8056
FAX No. 775-834-8153
E-mail: mdufur@tmwa.com

C. Interpretations and Addenda

Bidders shall take no advantage of any apparent error or omission in the Bidding Documents. In the event a Bidder discovers such an error or omission, it shall immediately notify the Contract Administrator in writing. Truckee Meadows Water Authority will then make such corrections and interpretations as may be deemed necessary for fulfilling the intent of the Bidding Documents. Any Addendum or written clarification supplementing the Plans, Specifications, and Contract Documents issued prior to the time set for the submittal of Bid Proposal shall be made part of the Contract.

If it becomes necessary to issue a written addendum, a copy will be provided on Truckee Meadows Water Authority Web Site for free download at http://tmwa.com/about_us/doingbusinesswithtmwa Truckee Meadows Water Authority is not bound by any oral representations, clarifications, or changes made by employees, or representatives, unless such clarification or change is provided to all Bidders in written form. No significant Addendum shall be issued by Truckee Meadows Water Authority less than one (1) working day prior to the advertised date and time for Bid submittal unless the bid date is extended.

Prior to submission of the Bid, each Bidder shall ascertain that it has received all Addenda issued. The Bidder shall acknowledge receipt of all Addenda by completing the acknowledgment space provided on the Bid Schedule.

D. Bid Preparation and Submission

1. Bid proposals are to be submitted on the Bid Schedule provided and must be manually signed by pen by an officer or authorized agent (with attached power of attorney) of the Bidder. All figures must be written in ink or typewritten. Figures written in pencil or erasures are not acceptable. Any interlineation or alteration must be initialed in ink by a person authorized to bind the Bidder to a Contract. If the person making said interlineation or alteration is not the same person who signs the Bid Proposal, such person must write his/her signature and print his/her name and title on each page of the Bid Proposal where initials appear. Written delegation of signature authority to an agent acting on behalf of the Bidder must accompany the sealed Bid and cannot contain any language which states the Bidder retains final approval of acceptance of any of the terms conditions, specifications and/or finalized Contract.
2. Each Bid shall be submitted in a sealed envelope and the envelope must be prominently marked on the lower left corner as follows:

PWP CONTRACT NO.: PWP-WA-2015-235

OPENING: July 31, 2015

COMPANY NAME:

Truckee Meadows Water Authority will not consider a Bid that fails to comply with the above stated requirements. Truckee Meadows Water Authority will not be responsible for the premature opening of a Bid not properly addressed or identified. All Bids must be received prior to the time and date specified in the Invitation to Bid at the following address:

**Truckee Meadows Water Authority
P.O. Box 30013, Reno, NV 89520-3013
or
1355 Capital Boulevard, Reno, NV 89502
Attn: Maria Dufur**

3. If forwarded by mail, the sealed envelope containing the Bid must be enclosed in another envelope addressed as specified. Mailed Bids must be received by Truckee Meadows Water Authority prior to the closing time for receipt of Bids to receive consideration. Email or Facsimile Bids will not be accepted or considered.

E. Documents Necessary For Submittal

The Bid Bond, Bid Schedule Form, and Bid Preference Certificate of Eligibility (if applicable) comprise the Bid Proposal and all shall be included in the sealed envelope. Truckee Meadows Water Authority will not consider a Bid received if there is an omission of or failure to complete any portion of the required documents prior to the time of Bid Opening. Do not submit the entire bid book. A separate (loose) Bid bond and Bid Schedule Form are provided in the bid document for bid submission.

F. Bid Security

1. Each Bidder's Proposal must be accompanied by a Cashier's check, Certified Check, or Bid Bond acceptable to Truckee Meadows Water Authority in an amount equal to at least five percent (5%) of the Bidder's "Base Bid" Proposal. Bid Security shall be payable without condition to Truckee Meadows Water Authority as a guarantee that the Bidder, if awarded the Contract, will promptly execute the Contract in accordance with the Bid Proposal and in the manner and form required by the Contract Documents, and will furnish the required Performance and Payment bonds. Should the Bidder refuse to enter into such Contract or fail to furnish such bonds, the amount of the Bid security may be forfeited to Truckee Meadows Water Authority as liquidated damages, not as penalty. All checks must indicate the Payee as "Truckee Meadows Water Authority" and reflect the Bid number. Failure to enclose Bid security with the sealed Bid will cause the Bid to be rejected and not considered.
2. Surety companies issuing bid bonds must be licensed to issue surety by the State of Nevada Insurance Division. Bonds issued by an individual surety are not acceptable to Truckee Meadows Water Authority.
3. Truckee Meadows Water Authority will have the right to hold the Bid security of Bidders to whom an award is being considered until either (a) the Contract has been executed and bonds have been furnished, or (b) the specified time has elapsed so that Bids may be withdrawn, or (c) all Bids have been rejected.

G. Quantities

The quantities given in the Contract Documents or indicated by the unit Bid items are approximate quantities and are intended to illustrate Scope of Work. The Contractor shall be responsible for verifying the exact quantities involved each month through the measurement and payment provisions of the Contract Documents.

H. Compensation

The Total Bid Price shall cover all Work required by the Contract Documents and necessary or reasonably inferable to achieve completion of the Work. All costs in connection with the proper and successful completion of the Work, including furnishing all materials, equipment, supplies, and appurtenances; providing all construction equipment, tools and temporary utilities; and performing all necessary labor and supervision to fully complete the Work, shall be included in the unit and lump sum prices Bid. All Work not specifically identified as a pay item in the Bid Schedule shall be considered a non-compensatory obligation of the Contractor, and all costs in connection therewith shall be deemed included in the prices otherwise Bid.

I. Schedule of Values

The purpose of the Schedule of Values shall serve Truckee Meadows Water Authority in two (2) distinct areas:

1. PRIOR TO AWARD OF BIDS - Truckee Meadows Water Authority may request a Schedule of Values for any or all item(s) included in the Bid schedule for the purpose of determining an unbalanced Bid. The analysis shall be conducted by Truckee Meadows Water Authority. All prospective Bidders may be required to prepare a Schedule of Values, and it shall be the Bidder's responsibility to verify the quantities as shown on the Drawings before preparing his Bid. The schedule as shown in the Bid Schedule does not constitute a complete outline of the Work to be performed by the Contractor in accordance with the Contract Drawings and Specifications. This list is intended to include all major items, and the Bid computed there from will be the maximum compensation for all work and materials furnished by the Contractor in order to comply with the Contract Drawings and Specifications, whether or not indicated in the approximate quantities or pertaining to the items of Work listed therein
2. AFTER AWARD OF BID - Truckee Meadows Water Authority will request a Schedule of Values for any or all item(s) included in the Bid schedule for the purpose of making partial payments to the Contractor.

Under no circumstances may any Bid item reflected as LUMP SUM or otherwise be increased or decreased as a result of the Lump Sum Bid breakdown analysis.

J. Validity of Bid

Truckee Meadows Water Authority reserves the right to withhold award of this Contract for a period of thirty (30) days from the date of the Bid opening. The Bidder acknowledges in submitting his/her Bid that all prices listed in the Bid Proposal are valid for a period of not less than thirty (30) days from the date of the Bid Opening.

K. Bidders Preference

Bidders submitting a proposal to a public body for a Public Work shall bear the responsibility to ascertain the relevancy of the "preference for certain contractors" referenced in NRS Chapter 338. Bidders claiming preference shall submit with their Bid Proposal 1) the "Certificate of Eligibility" issued by the State of Nevada Contractor's Board and 2) the Affidavit of Local Bidders Preference as proof of Contractor's compliance with the provisions of NRS Section 338. Failure to submit the Certificate of Eligibility and Affidavit with your Bid shall result in a waiver of any Bidder preference.

Note: The provisions in NRS 338 regarding the Bidder's Preference Certificate issued by the State Contractors Board and the Local's Preference Affidavit (provided in this bid document) do not apply to any Contract for a Public Work which is expected to cost less than \$250,000.

L. Bidders Representation

Each Bidder by submitting its Bid represents and warrants that:

1. The Bidder, by submission of his Bid, confirms it has familiarized itself with the Invitation to Bid, Notice To Contractors, Plans, Specifications, and Contract Documents and has found them fit and sufficient for the purpose of preparing his Bid. Bidder agrees to all the terms and conditions of the Contract and further agrees that no claim will be made against Truckee Meadows Water Authority, the Project Representative, or the Design Consultant for any damage that he or his subcontractors may have suffered due to the inadequacy of his Bid on account of any alleged errors, omissions, or other deficiencies in the Notice To Contractors, Plans, Specifications, or Contract Documents supplied to him by Truckee Meadows Water Authority.

2. The submission of a Bid shall constitute an acknowledgment upon which Truckee Meadows Water Authority may rely that the Bidder has thoroughly examined and is familiar with the Contract Documents. The Bidder shall in no way be relieved from any obligation with respect to its proposal or to the Contract. ***No claim for additional compensation will be allowed which is based upon a lack of knowledge of the Contract Documents.***

3. The Bidder has inspected the site(s) of the Work and is fully satisfied, by personal examination or by other means, of the locations of the proposed Work, of the actual conditions, including subsurface conditions, of and at the site(s) of the Work. If, during the course of its examinations, a Bidder finds facts or conditions which appear to be in conflict with the letter or spirit of the Bidding documents before submitting his/her bid, the Bidder shall request Truckee Meadows Water Authority, in writing, to provide additional information and explanation.

4. Submission of a Bid by a Bidder shall constitute conclusive evidence that the Bidder has relied solely and exclusively on its own examination of (1) the site of the Work, (2) access to the site, (3) all other data and matters requisite to the fulfillment of the Work and on its own knowledge of existing facilities on and in the vicinity of the site of the Work to be constructed under the Contract, (4) the conditions to be encountered, (5) the character, quality and scope of the proposed Work, (6) the quality and quantity of the materials to be furnished, and (7) the requirements of the Bid, the Drawings and Specifications. The Bidder is aware that soil classifications do not represent any particular stability or drainability characteristics, and are aware that water table levels can vary. ***No claim for additional compensation will be allowed which arises because of Bidder's failure to examine or become fully aware of the items in this paragraph.***

5. The information provided by Truckee Meadows Water Authority is provided for informational purposes only, without representation or warranty of any kind with respect to its accuracy or completeness, and is not intended to and shall not be relied upon as a substitute for, or a supplement to, the independent investigation by the Bidder of site conditions.

6. The Bidder, by signing the Bid Schedule, agrees that all material and workmanship on this Project shall meet or exceed OSHA standards and NOSHA standards.

7. The Bidder is qualified and possesses, at the time of the Bid submittal, a valid contractor's license for this particular Work (both as to type and available dollar limit) issued by the Nevada State Contractor's Board. Nevada Contractor's License type, number, expiration date and dollar limit must be indicated on the Bid Schedule. The Bidder and their subcontractors shall comply with all provisions of NRS Chapter 624 and Nevada Administrative Code, Chapter 624. Truckee Meadows Water Authority will not consider any Bid that fails to comply with these requirements.

8. The Bidder has a valid Business License and shall submit a copy with the bonds and Contract after award of contract.

9. The Bidder has appropriate work experience to be qualified to construct the Work. Bidder has successfully constructed at least three similar projects of equal or greater size, scope, type, cost, and complexity within the previous seven years. A similar project is one of the same category as this Project, defined for purposes of this paragraph as production wells. Bidders must have such prior work experience in order to be deemed responsive or responsible for purposes of bid evaluations. TMWA considers it critical to public health and safety and in the best interests of TMWA that this work only be performed by contractors holding such prior experience.

a. Evidence of the Contractor's required project experience shall be provided in the reference section of the Proposal Summary section (additional sheets may be attached as necessary).

b. The requirements for submittal of required project experience also apply to proposed Subcontractors performing specialty work, including piping, control valve, electrical, power, telemetry, and equipment control work. Subcontractor experience shall be provided with submission of the final subcontractor list.

Project categories to be evaluated consist of: treatment facilities, booster pump stations, wells, storage tanks, distribution pipelines, transmission pipelines, meter and regulator stations, and trenchless installation.

The storage tank category is further subdivided into steel, prestressed concrete, and reinforced concrete tanks.

1. The pipeline category is further subdivided as follows:

- i. Distribution pipelines: Pipes carrying potable water; generally smaller than 18 inches in diameter; constructed of ductile iron pipe or PVC pipe using appurtenances typically stocked at supply houses; design pressures are 150 psi or less. Storm drain, sewer, and gas pipelines are not distribution pipelines.
- ii. Transmission pipelines: Pipes carrying either potable water, partially treated water, or raw water; typically 18 inches and larger in diameter; constructed of ductile iron pipe, concrete cylinder pipe, or steel pipe; design pressures are often higher than 150 psi. May utilize materials that are manufactured specifically for the project. Storm drain, sewer, and gas pipelines are not transmission pipelines.

TMWA will determine in its sole and absolute discretion whether a Contractor is responsible, properly licensed, and has the requisite work experience required above to be eligible to construct this Project. Bids by Contractors that lack the proper license or requisite work experience set forth above will be rejected as non-responsible, non-responsive, and/or not in the best interests of TMWA.

M. Subcontracting

The Bidder shall be bound by and comply with NRS Section 338.141 to limit the practice of shopping for Bids and shall provide Subcontractors Lists required by NRS 338.141 with the submission of their Bid. The Bid must include a completed Five Percent List (in the form attached) identifying the name each first tier subcontractor who will be paid an amount exceeding five percent (5%) of the Bid amount, along with a description of the labor or portion of the work the subcontractor will perform. Within two (2) hours after the opening of Bids, the bidders who submitted the three lowest Bids must submit a completed Two Hour List (in the form attached) identifying the names of each first tier subcontractor who will provide labor or a portion of the Work or improvement to the Contractor for

which he will be paid (a) an amount exceeding \$250,000; AND (b) an amount exceeding one percent (1%) of the Bid amount or Fifty Thousand Dollars (\$50,000), whichever is greater, and for all subcontractors listed a description of the labor or portion of the work the subcontractor will perform, the subcontractor's license number and classification, and anticipated amount of the subcontract.

The Bidder must include the Bidder's name in the Five Percent List and Two Hour List. If the Bidder intends to self-perform any portion of the Work exceeding 1% of the Bid amount, the Bidder must also include in the Five Percent List and Two Hour List required by NRS 338.141a description of the labor or portion of the Work the Bidder will self-perform or a statement that the prime contractor will perform all work other than that being performed by a subcontractor listed in the Five Percent List and the Two Hour List required by NRS 338.141. If a Bidder fails to submit such lists within the required time, the Bid shall be deemed non-responsive.

The Bidder shall verify prior to submitting their Bid that all subcontractors specified are properly licensed. Substitutions of subcontractors specified in the Bid shall comply with the requirements of NRS Section 338.141. Should no firms be indicated on the Subcontractor Lists, the Bidder represents that all personnel performing services under any phases, shall be carried on the Bidder's payroll.

Bidder agrees that if awarded the Contract, he will assume responsibility and defend, protect, and indemnify Truckee Meadows Water Authority as set forth in the General Conditions for acts or omissions of subcontractors and of persons either directly or indirectly employed by them, as they are responsible for the acts or omissions of persons directly employed by the Bidder. Nothing contained in the Contract Documents shall create any contractual relationship between any subcontractor and Truckee Meadows Water Authority.

Each Contractor engaged on a public works project shall report to the Labor Commissioner and TMWA the name and address of each Subcontractor, regardless of tier, whom he engages for work on the project within ten (10) days after the Subcontractor commences work on the contract.

As used herein, the term "subcontractor" means a person who:

- (a) Is licensed pursuant to the provisions of chapter 624 of NRS or performs such work that the person is not required to be licensed pursuant to chapter 624 of NRS; and
- (b) Contracts with a contractor, another subcontractor or a supplier to provide labor, materials or services for a construction project."

II. OPENING OF BIDS

A. Opening of Bids.

All Bids received on time and that comply with these requirements will be opened and publicly read aloud at the time and place set forth in the Invitation to Bid. Bidders, their representatives, and all other interested persons may be present at the opening and reading of Bids. Any Bids received after the time for receiving and opening Bids, as set forth in the Notice To Bidders and any Addendum, will not be considered. Any such Bids will be returned unopened to the Bidder.

B. Mistake In Bid

A request for withdrawal of a Bid due to a purported error shall not be considered unless it is given in writing to the Contract Administrator by the Bidder within forty-eight (48) hours after opening of the bid. Any such request shall contain a full explanation of any purported error and shall be supported by the original calculations on which the Bid was computed, together with a certification and notarization thereon that such calculation is the original as prepared by the Bidder or his agent.

In the case of a difference between written words and figures, the amount stated in written words shall govern for a Lump Sum Bid.

In the case of a difference between Unit Price and the extended price, the Unit Price shall govern.

C. Withdrawal of Bid

Before Bid Opening - A Bidder may request withdrawal of his/her posted, sealed Bid prior to the scheduled Bid opening time provided the request is submitted to the Contract Administrator's Office in writing or an authorized representative must present himself with proper identification to the Contract Administrator's office and verbally request that the Bid be withdrawn.

After Bid Opening - No Bids may be withdrawn for a period of thirty (30) calendar days after the date of Bid opening, except as set forth in A above. All responsive and responsible Bids received are considered firm offers for the time period specified above and may be considered for award. The Bidder's offer will expire at the time specified above or upon acceptance by Truckee Meadows Water Authority, which occurs when the successful Bidder provides the bonds, insurance, and submits the signed Contract to Truckee Meadows Water Authority for execution and Truckee Meadows Water Authority executes the Contract.

III. AWARD OF CONTRACT/REJECTION OF BIDS/DISQUALIFICATION OF BIDDERS

A. Award of Contract

Truckee Meadows Water Authority will award the Contract pursuant to the provisions of State law including but not limited to:

- (a) Chapter 332 (Purchasing: Local Governments)
- (b) Chapter 338 (Public Works Projects)
- (c) Chapter 339 (Contractor's Bonds on Public Works)
- (d) Chapter 624 (Contractors).

B. Rejection of Bids

Truckee Meadows Water Authority reserves the right to waive any informality or irregularity in any Bid received, and to reject any or all Bids. In the case of rejection of all Bids, Truckee Meadows Water Authority reserves the right to advertise for new Bids or to proceed to do the Work otherwise if it is in the best interest of Truckee Meadows Water Authority.

C. Irregular Bid

A Bid shall be considered irregular for the following reasons, any one or more of which may be cause for rejection:

- 1. If the Bid Schedule furnished by Truckee Meadows Water Authority is not used or is altered.
- 2. If there are unauthorized additions, conditional or alternate Bids, or omissions or irregularities of any kind which may tend to make the Bid incomplete, indefinite or ambiguous as to its meaning, or give the Bidder submitting the same an unfair competitive advantage over other Bidders.
- 3. If the Bid submitted contains any erasure, interlineations, or other corrections unless each such correction is prepared and authenticated in acceptance with the provisions of Paragraph IB.1.E (1).

D. Unbalanced Bid

If the Unit Bid Item prices and/or schedule of values of a prospective Bidder's Bid are obviously unbalanced, either in excess or below the reasonable cost analysis values, the Bid may be rejected.

All Bids with separately priced line items shall be analyzed to determine if the prices are unbalanced. A bid may be rejected if Truckee Meadows Water Authority determines that the lack of balance poses an unacceptable risk to Truckee Meadows Water Authority.

A Bid with unbalanced pricing may increase performance risk and could result in payment of unreasonably high prices. Unbalanced pricing exists when, despite an acceptable total evaluated price, the price of one or more bid items is significantly over or understated as indicated by the application of cost or price analysis techniques. The greatest risks associated with unbalanced pricing occur when:

1. Over pricing of startup work, mobilization, or early items of work (front end loading) would cause a bidder to receive substantial up-front payment;
2. Base quantities and option quantities are separate line items;
3. The quantities as bid are incorrect and the contract cost will be increased when quantities are corrected; or
4. On items where the quantities may vary, if the anticipated variation in quantity would result in the lower Bidder not remaining as the low Bidder.

E. Disqualification of Bidders

Any one or more of the following may be considered as sufficient for the disqualification of a prospective Bidder and the rejection of the Bid:

1. The Bidder is not responsive or responsible;
2. The quality of the services, materials, equipment or labor offered does not conform to the approved Contract plans and specifications;
3. Evidence of collusion among prospective Bidders; (Participants in such collusion will receive no recognition as Bidders)
4. Lack of contractor's license classification required by Truckee Meadows Water Authority for this Work;
5. More than one Bid for the same work from an individual, firm, or corporation under the same or different name;
6. Lack of competency, understanding of the scope of the Work, adequate machinery, plant and/or equipment as revealed by the requested experience or subcontractor information;
7. Unsatisfactory performance record as shown by past work for Truckee Meadows Water Authority, judged from the standpoint of workmanship, progress, and quality of services/goods provided;
8. Uncompleted work which, in the judgment of Truckee Meadows Water Authority, might hinder or prevent the prompt completion of additional work, if awarded;
9. Failure to pay or satisfactorily settle all bills due for labor and material on any contract(s);
10. Failure to comply with any requirements of Truckee Meadows Water Authority;
11. Failure to list, as required, all subcontractors who will be employed by the Bidder;
12. Negative actions against the Contractor's license by the Nevada State Contractor's

Board; or

13. Any other reason determined, in good faith, to be in the best interest of Truckee Meadows Water Authority.

IV. BID PROTESTS

The Truckee Meadows Water Authority Contracts Division will post the recommendation for award of this Contract on the website: http://www.tmh2o.com/about_us/doingbusinesswithtmwa/ . Any Bidder which submitted a bid to TMWA may protest the recommendation for award in accordance with the procedures set forth in NRS 338.142. The protest must be submitted in writing to TMWA's Purchasing and Contracts Administrator. In addition to any other information required by law, the protest shall include the following information:

1. The alleged violation(s) of: (a) Contract Documents referencing page number, item, and paragraph; (b) Nevada Revised Statutes referencing the specific chapter, section, and subsection; or (c) Local codes or ordinances referencing section number; and
2. Supporting documentation such as Nevada State Contractors Board licensing information or other detailed proof to substantiate the protest.

The Bidder filing the protest shall, at the time the protest is filed, post a bond with a good and solvent surety authorized to do business in the state of Nevada, or submit a cashier's check, money order, or certified check, to TMWA who will hold the bond or other security until a determination is made on the protest. The bond or other security submitted with the protest shall be in an amount equal to the lesser of 25 percent of the total Base Bid submitted by the Bidder filing the protest, or \$250,000.00.

If the protest is upheld, the bond or other security will be returned to the Bidder who submitted the protest. If the protest is rejected, a claim may be made by TMWA against the bond or other security in an amount equal to the expenses incurred by TMWA because of the unsuccessful protest. Any money remaining after the claim has been satisfied will be returned to the Bidder who posted the bond or submitted the security.

The protest filed in accordance with these provisions operates as a stay of action in relation to award of the Contract until a determination is made by TMWA on the protest.

An unsuccessful Bidder may not seek any type of judicial intervention until TMWA has made a determination on the protest and awarded the Contract.

TMWA will not be liable for any costs, expenses, attorney's fees, loss of income, or other damages sustained by a Bidder, whether or not the Bidder files the protest.

TMWA's Administrator of Purchasing and Contracts will promptly issue a decision in writing to the protester and any other party intervening. If the protester or any other intervening party wishes to appeal the decision rendered by TMWA's Administrator of Purchasing and Contracts to the TMWA Board, such appeal shall be made within 48 hours from receipt of the decision by submitting a notice of appeal in writing to TMWA's Administrator of Purchasing and Contracts.

An award recommendation will be made and presented to the Truckee Meadows Water Authority for a final decision. TMWA will not consider protests unless the procedures specified in this Section are followed.

V. BID PREPARATION EXPENSES

By accepting the Bid Proposal of the Bidder, Truckee Meadows Water Authority assumes no

obligation to reimburse the Bidder for Bid preparation expenses. No Bidder shall have any right or claim against Truckee Meadows Water Authority for reimbursement of Bid preparation expenses.

VI. COLLUSION, DISCRIMINATION, AND/OR PRICE FIXING

The Bidder certifies that any and all prices which he may charge under the terms of the Contract do not, and will not, violate any existing federal, state or municipal laws or regulations concerning discrimination and/or price fixing. The Bidder agrees to indemnify, exonerate and hold Truckee Meadows Water Authority harmless from liability for any such violation now and throughout the term of the Contract.

VII. CONTRACT AWARD

A. Method of Award. The Bid, if awarded, will be awarded to the lowest responsive and responsible Bidder (contracts less than \$100,000) or to the best bidder for contracts in excess of \$250,000 based on the Total Base Bid amount, plus or minus any or all Additive or Deductive Alternates, that is most advantageous to Truckee Meadows Water Authority. Bidder must bid all items to be responsive and considered for award.

B. Time of Award. The award, if made, will be within thirty (30) calendar days after the opening of Bids. Truckee Meadows Water Authority reserves the right to accept or reject any or all Bids received.

C. Bonds. The successful contractor will be required to provide the Bonds as indicated in Article 5 of the General Conditions.

D. Insurance. Insurance as described in the General Conditions shall be required of the Contractor not later than ten (10) calendar days after receipt of the Notice of Award. The Contractor shall procure and maintain, at its own expense, all the insurance required as stated herein, and shall submit coverage verification (certificates) for review and approval by Truckee Meadows Water Authority. A Notice to Proceed may be issued prior to receipt of the required insurance, bonds, and signed contracts starting the time for contract performance on the project, however, the Contractor will not be permitted to work prior to Truckee Meadows Water Authority's receipt and approval of the insurance, bonds and signed contract. Said certificates shall be specific to the project and all notices regarding insurances shall be delivered to:

Truckee Meadows Water Authority
Attn: Maria Dufur, Purchasing and Contracts Administrator
P. O. Box 30013
Reno, NV 89520

The Notice to Proceed shall not be issued and Contractor shall not commence work, until such insurance has been approved by Truckee Meadows Water Authority. The Contractor shall not allow any subcontractors to commence work on its subcontract until all similar insurance required of the subcontractor has been obtained and verified by Contractor. Such insurance shall remain in full force and effect at all times during the execution of the Work and until the final completion and acceptance thereof and at all times thereafter as dictated in this Contract and the General Conditions.

If the Contractor fails to maintain any of the insurance coverages required herein, Truckee Meadows Water Authority will have the option to declare the Contractor in breach, or may purchase replacement insurance or pay the premiums that are due on existing policies in order that the required coverages may be maintained. The Contractor is responsible for any expenses paid by Truckee Meadows Water Authority to maintain such insurance and Truckee Meadows Water Authority may collect the same from the Contractor or deduct the amount paid from any sums due the Contractor under the Contract.

The insurance requirements specified herein do not relieve the Contractor of responsibility or limit the amount of liability to Truckee Meadows Water Authority or other persons, and the Contractor is encouraged to purchase such additional insurance as he deems necessary.

E. Penalty for Collusion. If, at any time, it is found that the Contractor has, in presenting any bid or bids, colluded with any other party or parties, then the Contract shall be null and void, and the Contractor and its sureties shall be liable for loss or damage which Truckee Meadows Water Authority may suffer thereby, and Truckee Meadows Water Authority may advertise for new bids for said Work. The Contractor further certifies that any and all prices which he may charge under the terms of the Contract do not, and will not, violate any existing Federal, State or Municipal laws or regulations concerning discrimination and/or price fixing.

F. Copeland Anti-Kickback Law. The Contractor shall comply with the Copeland Anti-Kickback Act (19 U.S.C. 874) as supplemented in the Department of Labor Regulations (29 CFR Part 3). This act provides that each Contractor or subcontractor shall be prohibited from inducing by any means, any person employed in the construction, completion or repair of public work, to give up any part of the compensation to which he is otherwise entitled.

G. Media Contact. The Contractor shall immediately contact the TMWA Project Manager assigned to them, if they are approached by the media while working on any TMWA project.

END OF INSTRUCTIONS TO BIDDERS

BID PROPOSAL FORMS

BID BOND

KNOW ALL MEN BY THESE PRESENTS, that I/We _____

as Principal, hereinafter called Contractor, and

a corporation duly organized or authorized to do business under the laws of the State of Nevada, as Surety, hereinafter called the Surety, are held and firmly bound unto Truckee Meadows Water Authority, a joint powers authority created pursuant to NRS Chapter 277, for the sum of \$ _____ Dollars

(state sum in words)

for the payment whereof Contractor and Surety bind themselves, their heirs, executors, administrators, successors and assigns, jointly and severally, firmly by these presents. This bond shall be governed by the laws of the State of Nevada.

WHEREAS, the Principal has submitted a bid, identified as **PWP No: WA-2015-235** and titled "**Innovation Well and Army Aviation Well Drilling, Construction, Development and Testing.**"

NOW, THEREFORE if Truckee Meadows Water Authority shall accept the bid of the Principal and the Principal shall enter into a contract with Truckee Meadows Water Authority in Accordance with the terms of such bid, and give such bond or bonds as may be specified in the bidding or Contract Documents with good and sufficient surety for the faithful performance of such Contract and for the prompt payment of labor and material furnished in the prosecution thereof, or in the event of the failure of the Principal to enter such Contract and give such bond or bonds, if the Principal shall pay to Truckee Meadows Water Authority the difference not to exceed the penalty hereof between the amount specified in said bid and such larger amount for which Truckee Meadows Water Authority may in good faith contract with another party to perform work covered by said bid or an appropriate liquidated amount as specified in the Invitation for Bids then this obligation shall be null and void, otherwise to remain in full force and effect.

Executed on this _____ day of _____, 20____

(Signature of Principal)

Name: _____

Title: _____

(Seal)

Firm: _____

Address: _____

City/ State / Zip Code: _____

Written Name of Principal: _____

(Signature of Notary)

ATTEST NAME: _____

Subscribed and sworn before me this _____ day of _____, 20____

(printed name of notary)

Notary Public for the State of _____

Claims Under This Bond May Be Addressed To:	
Name of Surety	
Address	
City	
State/Zip Code	
Name	
Title	
Phone	
Surety's Acknowledgment	

NOTICE: No substitution or revision to this bond form will be accepted. Sureties must be authorized to do business in and have an agent for service of process in the State of Nevada. Certified copy of Power of Attorney must be attached.

BID SCHEDULES
(Cont)

BID SCHEDULES

PWP #: PWP-WA-2015-235

BID TITLE: Innovation Well and Army Aviation Well Drilling, Construction, Development and Testing

NOTICE: No substitution or revision to this Bid Schedule form will be accepted. Truckee Meadows Water Authority will reject any Bid that is received that has changes or alterations to this document. Although the Prevailing Wages are provided in this bid document, the bidder is responsible to verify with the Labor Commissioner if any addendums have been issued. If different, the successful bidder will be required to provide the current Prevailing Wages used in preparation of their bid within 24 hours of bid submission.

PRICES must be valid for 30 calendar days after the bid opening.

A COPY OF THE "CERTIFICATE" of eligibility to receive a preference in bidding on public works issued to him/her by the State Contractors' Board and (if claiming Locals Preference) the Local's Preference Affidavit (provided above) must be submitted with his/her bid to the Contracts Division for the preference to be considered. These Statutes do not apply to projects expected to cost less than \$250,000.

COMPLETION of this project is expected **PURSUANT TO CONTRACT DOCUMENTS**.

BIDDER acknowledges receipt of _____ Addendums.

Item pricing on this schedule is for use in preparing the schedule of values that will be used as a basis for partial payment during construction and for internal TMWA use. Item descriptions are not intended to be all inclusive. Bidders shall include costs for work not specifically mentioned in the most appropriate item.

Refer to Article 7 of the General Conditions for a list of items that may be included in the mobilization bid item. TMWA reserves the right to perform extra work using time and expense or negotiated lump sum procedures.

The Contract Sum will be adjusted (increased or decreased) for actual quantities per unit price items. Lump sum items will not be adjusted.

Compliance with all permit and environmental requirements is incidental to the Work. No separate bid item, or additional payment provisions, shall be made for operational constraints or conditions placed on the Work by permitting agency requirements.

(signature)

SUMMARY

Description	Scheduled Value	Unit	Unit Price	Total Price
INNOVATION WELL				
1. Mobilization / demobilization: Innovation well site	1	\$ Lump Sum		

BID SCHEDULES
(Cont)

Description	Scheduled Value	Unit	Unit Price	Total Price
2. Drill 30-inch borehole from ground surface to 40 feet, using auger rig or direct mud rotary drilling technique.	40	\$ Per Foot		
3. Furnish and install 24-inch, 0.312-inch wall steel blank well casing.	40	\$ Per Foot		
4. Furnish and install cement in the annulus between the casing and the borehole wall.	3	\$ Per Cubic Yard		
5. Drill nominal 24-inch diameter from 40 to a depth of 310 feet.	270	\$ Per Foot		
6. Provide geophysical logging services: spontaneous potential, resistivity, and caliper.	1	\$ Lump Sum		
7. Furnish and install nominal 14-inch 0.312-inch wall stainless steel blank well casing. Casing shall be stainless steel, type 304L, in accordance with applicable parts of ASTM A778.	200	\$ Per Foot		
8. Furnish and install nominal 14 inch, 0.312-inch wall, 0.080-inch-slot wire-wrap stainless steel screen. The stainless steel screen shall be type 304L in accordance with applicable parts of ASTM A778.	100	\$ Per Foot		
9. Furnish and install stainless steel casing centering guides at 40-foot intervals from 40 feet to total depth. (4 centering guides per interval).	7	\$ Per Interval		
10. Furnish and install one nominal 3-inch, stainless steel gravel feed tube with surface cap. The bottom opening of the tube shall be at 124 feet below ground surface.	126	\$ Per Foot		
11. Furnish and install one nominal 3-inch, stainless steel water injection tube. The pipe shall be attached to a Roscoe Moss entrance chamber box welded to the 14-inch blank casing at 90 feet below ground surface.	92	\$ Per Foot		
12. Furnish and install one nominal 2-inch diameter stainless steel water level sounding tube in annular space between 24-inch borehole and 14-inch casing from ground surface to 210 ft. The tube shall be attached to the blank casing using stainless steel bands and attached to the Roscoe Moss entrance chamber box.	212	\$ Per Foot		

BID SCHEDULES
(Cont)

Description	Scheduled Value	Unit	Unit Price	Total Price
13. Furnish and install 1/8-inch X 1/4-inch gravel pack in the annulus between 24-inch borehole and 14 inch casing from 120 feet to 310 feet.	15	\$ Per Cubic Yard		
14. Furnish and install bentonite pellet seal in the annulus between 24-inch borehole and 14 inch casing from 116 feet to 120 feet.	0.5	\$ Per Cubic Yard		
15. Furnish and install neat cement seal in the annulus between 24-inch borehole and 14 inch casing from ground surface to 116 feet.	10	\$ Per Yard ³		
16. Initial well development by a combination of methods including isolated swabbing with simultaneous airlift pumping, using high capacity compressor, 350 CFM and 150 psi.	40	\$ Per Hour		
17. Furnish and install approximately 1,200 feet of temporary discharge pipe (of adequate size to discharge up to 1,200 gpm to Dry Creek) and all other water decanting and conveyance equipment during well development and testing.	1,200	\$ Per Foot		
18. Hauling borehole cuttings approximately 5 miles to Glendale treatment facility.	6	\$ Per Trip		
19. Furnish, install and remove 1,200 gpm test pump. Pump setting is estimated to be 125 feet below ground surface.	125	\$ Per Foot		
20. Well development by surging and pumping with the test pump.	40	\$ Per Hour		
21. Perform 8-hour step test and 72-hour constant flow pump test.	80	\$ Per Hour		
22. Furnish, install and remove 3-inch steel pipe to 130 feet for running down the spinner flow tool	130	\$ Per Foot		
23. Re-install the test pump to 125 feet and pump the well for spinner flow survey. TMWA will contract with the spinner survey contractor	10	\$ Per Hour		
24. Perform video camera survey to check the integrity and exact depths of the casing and screen.	1	\$ Lump Sum		

BID SCHEDULES
(Cont)

Description	Scheduled Value	Unit	Unit Price	Total Price
25. Well cleaning, disinfection, and capping with steel plate. Steel plate shall have a 1" bushing and plug to measure the groundwater level.	1	\$ Lump Sum		
26. Temporary on-site waste facilities at the Innovation well site for two weeks.	1	\$ Lump Sum		
27. Temporary on-site office during pumping tests at the Innovation well site for two weeks.	1	\$ Lump Sum		
28. Stand-by hours for drilling and construction of the Innovation well, if requested by Owner.	10	\$ Per Hour		
29. Perform plumbness and alignment test in the constructed Innovation well as per AWWA A100-97. A Gyroscopic Deviation survey Drift-Pac analysis or equivalent shall be performed by a contractor experienced in such surveys. A well which fails to meet AWWA A100-97 requirements for alignment or plumbness as specified herein may be rejected at TMWA's discretion.	1	\$ Lump Sum		
TOTAL BID PRICE OF ITEMS 1 THROUGH 29 FOR THE INNOVATION WELL				
ARMY AVIATION WELL				
1. Mobilization / demobilization: from Innovation well site to Army Aviation well site.	1	\$ Lump Sum		
2. Drill 36-inch borehole from ground surface to 40 feet, using auger rig or direct mud rotary drilling technique.	40	\$ Per Foot		
3. Furnish and install 30-inch, 0.312-inch wall steel blank well casing.	40	\$ Per Foot		
4. Furnish and install cement in the annulus between the casing and the borehole wall.	4	\$ Per Cubic Yard		

BID SCHEDULES
(Cont)

Description	Scheduled Value	Unit	Unit Price	Total Price
5. Drill nominal 26-inch diameter from 40 to a depth of 620 feet.	580	\$ Per Foot		
6. Conduct borehole geophysical survey: spontaneous potential, resistivity, and caliper.	1	\$ Lump Sum		
7. Furnish and install nominal 18-inch 0.375-inch wall stainless steel blank well casing. Casing shall be stainless steel, type 304L, in accordance with applicable parts of ASTM A778.	450	\$ Per Foot		
8. Furnish and install nominal 18-inch, 0.375-inch wall, 0.090-inch-slot full flow louvered stainless steel screen. The stainless steel screen shall be type 304L in accordance with applicable parts of ASTM A778.	160	\$ Per Foot		
9. Furnish and install stainless steel casing centering guides at 40-foot intervals from 40 feet to total depth. (4 centering guides per interval).	14	\$ Per Interval		
10. Furnish and install one nominal 3-inch, stainless steel gravel feed tube with surface cap. The bottom opening of the tube shall be at 304 feet below ground surface.	306	\$ Per Foot		
11. Furnish and install two nominal 3-inch, stainless steel water injection tubes. The pipe shall be welded to a Roscoe Moss entrance chamber box on the 18-inch blank casing at 90 feet below ground surface.	184	\$ Per Foot		
12. Furnish and install two nominal 2-inch diameter stainless steel water level sounding tubes in annular space between 26-inch borehole and 18-inch casing to 360 ft. The tubes shall be attached to the casing using stainless steel bands and welded into the Roscoe Moss entrance chamber box.	724	\$ Per Foot		
13. Furnish and install 1/8-inch x 1/4-inch gravel pack in the annulus between 26-inch borehole and 18-inch casing from 300 feet to 620 feet.	23	\$ Per Cubic Yard		
14. Furnish and install bentonite pellet seal in the annulus between 26-inch borehole and 18-inch casing from 296 feet to 300 feet.	0.5	\$ Per Cubic Yard		

BID SCHEDULES
(Cont)

Description	Scheduled Value	Unit	Unit Price	Total Price
15. Furnish and install neat cement seal in the annulus between 26-inch borehole and 18 inch casing from ground surface to 296 feet.	22	\$ Per Cubic Yard		
16. Initial well development by a combination of methods including isolated swabbing with simultaneous airlift pumping, using high capacity compressor, 750 CFM and 300 psi.	65	\$ Per Hour		
17. Furnish and install approximately 1,000 feet of temporary discharge pipe (of adequate size to discharge up to 2,500 gpm) and all other water decanting and conveyance equipment during well development and testing.	1,000	\$ Per Foot		
18. Hauling borehole cuttings approximately 12 miles to Glendale treatment facility.	8	\$ Per Trip		
19. Furnish, install and remove 2,500 gpm test pump. Pump setting is estimated to be 290 feet below ground surface.	290	\$ Per Foot		
20. Well development by surging / pumping with test pump.	65	\$ Per Hour		
21. Perform 8-hour step test and 72-hour constant flow pump test.	80	\$ Per Hour		
22. Furnish, install and remove 3-inch steel pipe to 310 feet for running down the spinner flow tool	310	\$ Per Foot		
23. Re-install the test pump to 290 feet and pump the well for spinner flow survey. TMWA will contract with the spinner survey contractor	10	\$ Per Hour		
24. Perform video camera survey to check the integrity and exact depths of the casing and screen.	1	\$ Lump Sum		
25. Well cleaning, disinfection, and capping with steel plate. Steel plate shall have a 1" bushing and plug to measure the groundwater level.	1	\$ Lump Sum		
26. Temporary on-site waste facilities at the Army Aviation well site for two weeks.	1	\$ Lump Sum		

BID SCHEDULES
(Cont)

Description	Scheduled Value	Unit	Unit Price	Total Price
27. Temporary on-site office during pumping tests at the Army Aviation well site for two weeks.	1	\$ Lump Sum		
28. Stand-by hours for drilling and construction of the Army Aviation well, if requested by Owner.	10	\$ Per Hour		
29. Perform plumbness and alignment test in the constructed Innovation well as per AWWA A100-97. A Gyroscopic Deviation survey Drift-Pac analysis or equivalent shall be performed by a contractor experienced in such surveys. A well which fails to meet AWWA A100-97 requirements for alignment or plumbness as specified herein may be rejected at TMWA's discretion.	1	\$ Lump Sum		
TOTAL BID PRICE OF ITEMS 1 THROUGH 29 FOR THE ARMY AVIATION WELL				
TOTAL BID PRICE FOR BOTH WELLS: INNOVATION WELL AND ARMY AVIATION WELL				

Total Bid Price FOR BOTH Innovation and Army Aviation Wells Written in Words:

Notes:

1. This project will be awarded in its entirety to one Contractor. Even if the bid for an individual site from another Contractor is low, the sites will not be separated for two Contractors. The lowest responsive responsible bidder for the total combined bid will be awarded the Contract.

BID SCHEDULES
(Cont)

BIDDER INFORMATION:

Company Name:
Address:
City:
State / Zip Code:
Telephone Number including area code:
Fax Number including area code:
E-mail:

LICENSING INFORMATION:

Nevada State Contractor's License Number:
License Classification(s):
Limitation(s) of License:
Date Issued:
Date of Expiration:
Name of Licensee:
City, State, Zip Code of Licensee:
Telephone Number of Licensee:

Business License Number:
Date Issued:
Date of Expiration:
Name of Licensee:
City, State, Zip Code of Licensee:
Telephone Number of Licensee:

Taxpayer Identification Number:

BID SCHEDULES

(Cont)

DISCLOSURE OF PRINCIPALS:

1. Individual and/or Partnership:

Owner 1) Name:
Address:
City, State, Zip Code:
Telephone Number:
Owner 2) Name:
Address:
City, State, Zip Code:
Telephone Number:
Other 1) Title:
Name
Other 2) Title:
Name:

2. Corporation:

State in which Company is Incorporated:
Date Incorporated:
Name of Corporation:
Address
City, State, Zip Code:
Telephone Number:
President's Name:
Vice-President's Name:
Other 1) Name:
Title:
Other 2) Name:
Title

BID SCHEDULES
(Cont)

MANAGEMENT AND SUPERVISORY PERSONNEL:

Persons and Positions	Years With Firm
Name	
Title	
Name	
Title	
Name	
Title	

(If additional space is needed, attach a separate page)

REFERENCES:

1. **Instructions:**

List at least three (3) contracts of a similar nature performed by your firm in the last three (3) years. If **NONE**, use your Company's letterhead (and submit with your bid proposal) a list what your qualifications are for this contract. Truckee Meadows Water Authority reserves the right to contact and verify, with any and all references listed, the quality of and the degree of satisfaction for such performance. See the Supplemental Conditions for the TMWA Project Category required for this project.

2. **Clients:** (if additional space is needed attach a separate page)

Owner's Representative :	Telephone #
Address (inc. City, State & Zip):	
Owner's Representative's E-mail:	
Superintendent:	
Amount of Contract:	Date Completed:
Project Title:	
TMWA Project Category:	
Owner's Representative :	Telephone #
Address (inc. City, State & Zip):	
Owner's Representative's E-mail:	
Superintendent:	
Amount of Contract:	Date Completed:
Project Title:	
TMWA Project Category:	

BID SCHEDULES
(Cont)

Owner's Representative :	Telephone #
Address (inc. City, State & Zip):	
Owner's Representative's E-mail:	
Superintendent:	
Amount of Contract:	Date Completed:
Project Title:	
TMWA Project Category:	
Project Name:	
Owner's Representative :	Telephone #
Address (inc. City, State & Zip):	
Owner's Representative's E-mail:	
Superintendent:	
Amount of Contract:	Date Completed:
Project Title:	
TMWA Project Category:	
Project Name:	
Owner's Representative :	Telephone #
Address (inc. City, State & Zip):	
Owner's Representative's E-mail:	
Superintendent:	
Amount of Contract:	Date Completed:
Project Title:	
TMWA Project Category:	

BID SCHEDULES

(Cont)

CERTIFICATION REGARDING DEBARMENT, SUSPENSION, AND OTHER RESPONSIBILITY MATTERS PRIMARY COVERED TRANSACTIONS

1. The prospective primary participant certifies to the best of its knowledge and belief, that it and its principals:
 - a) Are not presently debarred, suspended, proposed for debarment, declared ineligible, or voluntarily excluded by any Federal, State or Local department or agency.
 - b) Have not within a three-year period preceding this proposal been convicted of or had a civil judgment rendered against them for commission of fraud or a criminal offense in connection with obtaining, attempting to obtain, or performing a public (Federal, State or Local) transaction or contract under a public transaction; violation of Federal or State antitrust statutes or commission of embezzlement, theft, forgery, bribery, falsification or destruction of records, making false statements, or receiving stolen property.
 - c) Are not presently indicted for or otherwise criminally or civilly charged by a government entity (Federal, State or Local) with commission of any of the offenses enumerated in paragraph (1)(b) of this certification; and
 - d) Have not within a three-year period preceding this application/proposal had one or more public transactions (Federal, State or Local) terminated for cause or default.
2. Where the prospective primary participant is unable to certify to any of the statements in this certification, such prospective participant shall attach an explanation to this proposal.

Signature of Authorized Certifying Official

Title

Printed Name

Date

I am unable to certify to the above statement. My explanation is attached.

Signature

Date

BIDDER’S SAFETY INFORMATION

Bidder’s Safety Factors:

Year	“E-Mod” Factor ¹	OSHA Incident Rate ²
2013		
2014		

¹ E-Mod (Experience Modification) Factors are issued by the National Council on Compensation Insurance (NCCI).

² OSHA Incident Rate is the number of OSHA Recordable Accidents multiplied by 200,000 and then dividing that result by the total number of annual man-hours. Please refer to the U.S. Department of Labor Occupational Safety and Health Administration’s website for calculating worksheets and current requirements.

BID SCHEDULES

(Cont)

**NRS 338.141 LIST OF SUBCONTRACTORS AND CONTRACTOR SELF PERFORMANCE
EXCEEDING FIVE PERCENT OF BID AMOUNT
(FIVE PERCENT LIST)**

INSTRUCTIONS: List each first tier subcontractor who will be paid an amount **exceeding five percent (5%)** of the Bid amount and Contractor if it will self-perform work exceeding five (5) percent of bid amount. This information must be submitted with your bid proposal. The bidder shall enter “**NONE**” under “**Name of Subcontractor**” if not utilizing subcontractors exceeding this amount. (This form must be complete in all respects. If, additional space is needed, attach a separate page).

Name of Contractor		Address	
Phone	DUNS #	Nevada Contractor License #	Limit of License
Description of work being self performed by Contractor or statement that Contractor will perform all work other than that being performed by listed subcontractor(s):			
Name of Subcontractor		Address	
Phone	DUNS #	Nevada Contractor License #	Limit of License
Description of work being self performed by Contractor or statement that Contractor will perform all work other than that being performed by listed subcontractor(s):			
Name of Subcontractor		Address	
Phone	DUNS #	Nevada Contractor License #	Limit of License
Description of work being self performed by Contractor or statement that Contractor will perform all work other than that being performed by listed subcontractor(s):			
Name of Subcontractor		Address	
Phone	DUNS #	Nevada Contractor License #	Limit of License
Description of work being self performed by Contractor or statement that Contractor will perform all work other than that being performed by listed subcontractor(s):			
Name of Subcontractor		Address	
Phone	DUNS #	Nevada Contractor License #	Limit of License
Description of work being self performed by Contractor or statement that Contractor will perform all work other than that being performed by listed subcontractor(s):			

BID SCHEDULES

(Cont)

**FIRST TIER SUBCONTRACTORS AND CONTRACTOR SELF PERFORMANCE
EXCEEDING \$250,000, ONE PERCENT OF BID AMOUNT OR \$50,000
(TWO HOUR LIST)**

INSTRUCTIONS: List each first tier subcontractor who will be paid an amount exceeding a) **\$250,000;** and b) **one percent (1%) of the Bid amount, or \$50,000, whichever is greater,** and list Contractor if it will self-perform work exceeding one (1) percent of bid amount. This information must be submitted by the three lowest bidders within two (2) hours after the completion of the opening of the bids. Bidder shall enter “NONE” under “Name of Subcontractor” if not utilizing subcontractors exceeding this amount. (This form must be complete in all respects. If, additional space is needed, attach a separate page). Bidder may elect to submit this Two Hour List with the bid proposal and, in that case, the Bidder will be considered as having timely submitted the Two Hour List.

Name of Contractor		Address	
Phone	DUNS #	Nevada Contractor License #	Limit of License
Description of work being self performed by Contractor or statement that Contractor will perform all work other than that being performed by listed subcontractor(s):			
Name of Subcontractor		Address	
Phone	DUNS #	Nevada Contractor License #	Limit of License
Description of work being self performed by Contractor or statement that Contractor will perform all work other than that being performed by listed subcontractor(s):			
Name of Subcontractor		Address	
Phone	DUNS #	Nevada Contractor License #	Limit of License
Description of work being self performed by Contractor or statement that Contractor will perform all work other than that being performed by listed subcontractor(s):			
Name of Subcontractor		Address	
Phone	DUNS #	Nevada Contractor License #	Limit of License
Description of work being self performed by Contractor or statement that Contractor will perform all work other than that being performed by listed subcontractor(s):			
Name of Subcontractor		Address	
Phone	DUNS #	Nevada Contractor License #	Limit of License
Description of work being self performed by Contractor or statement that Contractor will perform all work other than that being performed by listed subcontractor(s):			

Local Preference Affidavit

**This preference does not apply to projects expected to cost less than \$250,000.
If the bid submitted is over \$250,000, this completed affidavit must be submitted with your bid response to be considered.**

State of _____)
)ss.
County of _____)

I, _____, on behalf of the Contractor, _____ (“Contractor”), hereby certify and affirm under penalty of perjury, for purposes of qualifying for a preference in bidding under Nevada Revised Statutes Chapter 338 on **PWP No.: WA-2015-235**, Project Name **Innovation Well and Army Aviation Well Drilling, Construction, Development and Testing** (“Project”), that the following requirements will be adhered to, documented and attained for the duration of the Project, collectively, and not on any specific day:

1. At least 50 percent of the workers employed on the Project (including subcontractors) hold a valid driver’s license or identification card issued by the Nevada Department of Motor Vehicles;
2. All vehicles used primarily for the public work will be (a) registered and (where applicable) partially apportioned to Nevada; or (b) registered in Nevada.
3. If applying to receive a preference in bidding pursuant to NRS 338.1727, at least 50 percent of the design professionals who work on the Project (including sub-contractors) hold a valid driver’s license or identification card issued by the Nevada Department of Motor Vehicles; and
4. The Contractor and any subcontractor engaged on the public work shall maintain and make available for inspection within Nevada all payroll records related to the Project.

Contractor recognizes and accepts that failure to comply with any requirements herein shall entitle the Truckee Meadows Water Authority (“Authority”) to a penalty in the amount set by statute. In addition, the Contractor recognizes and accepts that failure to comply with any requirements herein may lose its certification for a preference in bidding for 5 years and/or its ability to bid on any contracts for public works for one year pursuant to NRS Chapter 338.

By: _____ Title: _____

Signature: _____ Date: _____

Signed and sworn to (or affirmed) before me on this _____ day of _____, 20____, by _____ (name of person making statement).

_____ STAMP AND SEAL
Notary Signature

PREVAILING WAGE

PREVAILING WAGE

PREVAILING WAGE RATES

A. The Contractor and subcontractors shall be bound by and comply with all federal, state and local laws with regard to minimum wages, overtime work, hiring and discrimination, including Chapter 338 of the NRS, which is entitled, "Public Works Projects." The Contractor shall ensure that all employees on the work site are paid in accordance with the CURRENT PREVAILING WAGE RATES AS APPROVED BY THE STATE LABOR COMMISSIONER, whenever the actual value of the Contract totals One Hundred Thousand Dollars (\$100,000) or more, or when required by the Supplementary Conditions. A copy of the rates are attached hereto and included herein. If a Change Order causes a Contract to exceed One Hundred Thousand Dollars (\$100,000), the State Labor Commissioner may audit the entire Contract period.

When federal money is associated with the project making the Contract subject to both state and federal wage rates, the Contractor shall not pay less than the higher rate when the two rates differ for similar kinds of labor.

Questions involving the Prevailing Wage Rates for Truckee Meadows Water Authority should be referred to the Labor Commissioner, State of Nevada, at (775) 687-4850.

B. Posting of Minimum Wage Rates - In accordance with NRS, Chapter 338, Section 338.020, the Contractor shall post the hourly and daily rate of wages to be paid to each of the classes of mechanics and workers on the site of Work of this Contract in a place generally visible to the workers.

C. Pursuant to NRS 338.060 and 338.070, the Contractor hereby agrees to forfeit, as a penalty to Truckee Meadows Water Authority, not less than Twenty Dollars (\$20) nor more than Fifty Dollars (\$50) for each calendar day or portion thereof that each worker employed on the Contract is paid less than the designated rate for any work done under the Contract, by the Contractor or any subcontractor under him, or is not reported to Truckee Meadows Water Authority as required by NRS 338.070.

D. The contractor and each subcontractor shall keep or cause to be kept an accurate record showing, for each worker employed by the contractor or subcontractor:

- (1) The name of the worker;
- (2) The occupation of the worker;
- (3) If the worker has a driver's license or identification card, an indication of the state or other jurisdiction that issued the license or card; and
- (4) The actual per diem, wages and benefits paid to the worker.

In addition, the contractor and each subcontractor shall keep or cause to be kept an accurate record showing, for each worker employed by the contractor or subcontractor who has a driver's license or identification card:

- (1) The name of the worker;
- (2) The driver's license number or identification card number of the worker; and
- (3) The state or other jurisdiction that issued the license or card.

Truckee Meadows Water Authority will notify by e-mail the successful bidder through LCP Tracker Labor Compliance Software lcptracker.net that they have been assigned the project, . The General Contractor shall set up and notify each subcontractor utilized on the project through LCP Tracker Labor Compliance Software and ensure the receipt of a certified copy of each payroll for submission to Truckee Meadows Water Authority monthly.

E. The records in Section D above must be open at all reasonable hours to the inspection of Truckee Meadows Water Authority, and its officers and agents. A copy of the each record for each calendar Month for the General Contractor and all Sub-Contractors must be submitted to Truckee Meadows Water Authority through LCP Tracker no later than 15 days after the end of each month for the previous months' wages.



2015 PREVAILING WAGE RATES WASHOE COUNTY

DATE OF DETERMINATION: October 1, 2014

APPLICABLE FOR PUBLIC WORKS PROJECTS BID/AWARDED OCTOBER 1, 2014 THROUGH SEPTEMBER 30, 2015*

As of June 29, 2015, (10) Amendments have been issued by the Labor Commissioner for the 2014 - 2015 Wage Rates. Addenda 1 and 10 apply to Washoe County. It is attached for your reference. It is the responsibility of the bidder to verify that all Addendums have been reviewed prior to submission of your bid.

***Pursuant to NAC 338.040(3), "After a contract has been awarded, the prevailing rates of wages in effect at the time of the opening of bids remain in effect for the duration of the project."**

As Amendments/Addenda are made to the wage rates, such will be posted to sites of the respective counties. Please review regularly for any amendments posted or contact our offices directly for further assistance with any amendments to the rates.

PREVAILING WAGE RATES INCLUDE THE BASE RATE AS WELL AS ALL APPLICABLE FRINGES

NRS 338.010(21) "Wages" means:

- (a) The basic hourly rate of pay; and
- (b) The amount of pension, health and welfare, vacation and holiday pay, the cost of apprenticeship training or other similar programs or other bona fide fringe benefits which are a benefit to the workman.

NRS 338.035 Discharge of part of obligation of contractor or subcontractor engaged on public work to pay wages by making certain contributions in name of workman. The obligation of a contractor engaged on a public work or a subcontractor engaged on a public work to pay wages in accordance with the determination of the Labor Commissioner may be discharged in part by making contributions to a third person pursuant to a fund, plan or program in the name of the workman.

2014-2015 Prevailing Wage Rates

Amendment 1 (Clerical)

- Classification – *Flagperson, Laborer and Traffic Barrier Erector*
- County – Carson City, Douglas, Elko, Esmeralda, Eureka, Humboldt, Lander, Lyon, Mineral, Pershing, Storey, Washoe and White Pine
- Effective – October 9, 2014

The following represents the amended wage rates.

FLAGPERSON	<u>ADD LABORER ZONE RATE</u>
Flagperson	29.30
LABORER	<u>ADD ZONE RATE</u>
<u>SEE GROUP CLASSIFICATIONS</u>	
Landscaper	27.01
Furniture Mover	28.51
Group 1	32.17
Group 1A	29.30
Group 2	32.27
Group 3	32.42
Group 4	32.67
Group 4A	33.92
Group 5	32.97
Group 6	
Nozzlemen, Rodmen	32.97
Gunmen, Materialmen	32.67
Reboundmen	32.32
Gunite Foremen	33.37
TRAFFIC BARRIER ERECTOR	<u>ADD LABORER ZONE RATE</u>
Traffic Barrier Erector	32.17

2014-2015 Prevailing Wage Rates

Amendment 10 (Hearing)

- Classification – Fence Erector
- County – Carson City, Churchill, Douglas, Elko, Eureka, Humboldt, Lander, Lyon, Pershing, Storey, and Washoe
- Effective – March 1, 2015

The following represents the amended wage rates.

Fence Erector

Carson City	\$37.69
Churchill	\$37.69
Douglas	\$37.69
Elko	\$21.75
Eureka	\$35.07
Humboldt	\$21.75
Lander	\$21.75
Lyon	\$37.69
Pershing	\$42.57
Storey	\$37.69
Washoe	\$42.57



2015 PREVAILING WAGE RATES WASHOE COUNTY

DATE OF DETERMINATION: October 1, 2014

APPLICABLE FOR PUBLIC WORKS PROJECTS BID/AWARDED
OCTOBER 1, 2014 THROUGH SEPTEMBER 30, 2015*

***Pursuant to NAC 338.040(3), "After a contract has been awarded, the prevailing rates of wages in effect at the time of the opening of bids remain in effect for the duration of the project."**

As Amendments/Addenda are made to the wage rates, such will be posted to sites of the respective counties. Please review regularly for any amendments posted or contact our offices directly for further assistance with any amendments to the rates.

[AIR BALANCE TECHNICIAN](#)
[ALARM INSTALLER](#)
[BOILERMAKER](#)
[BRICKLAYER](#)
[CARPENTER](#)
[CEMENT MASON](#)
[ELECTRICIAN-COMMUNICATION TECH.](#)
[ELECTRICIAN-LINE](#)
[ELECTRICIAN-NEON SIGN](#)
[ELECTRICIAN-WIREMAN](#)
[ELEVATOR CONSTRUCTOR](#)
[FENCE ERECTOR](#)
[FLAGPERSON](#)
[FLOOR COVERER](#)
[GLAZIER](#)
[HIGHWAY STRIPER](#)
[HOD CARRIER-BRICK MASON](#)
[HOD CARRIER-PLASTERER TENDER](#)

2014-2015 Prevailing Wage Rates – Washoe County

[IRON WORKER](#)
[LABORER](#)
[MECHANICAL INSULATOR](#)
[MILLWRIGHT](#)
[OPERATING ENGINEER](#)
[OPERATING ENG. STEEL FABRICATOR/ERECTOR](#)
[OPERATING ENGINEER-PILEDRIIVER](#)
[PAINTER](#)
[PILEDRIIVER \(NON-EQUIPMENT\)](#)
[PLASTERER](#)
[PLUMBER/PIPEFITTER](#)
[REFRIGERATION](#)
[ROOFER \(Does not include sheet metal roofs\)](#)
[SHEET METAL WORKER](#)
[SPRINKLER FITTER](#)
[SURVEYOR \(NON-LICENSED\)](#)
[TAPER](#)
[TILE /TERRAZZO WORKER/MARBLE MASON](#)
[TRAFFIC BARRIER ERECTOR](#)
[TRUCK DRIVER](#)
[WELL DRILLER](#)
[LUBRICATION AND SERVICE ENGINEER \(MOBILE AND GREASE RACK\)](#)
[SOIL TESTER \(CERTIFIED\)](#)
[SOILS AND MATERIALS TESTER](#)

PREVAILING WAGE RATES INCLUDE THE BASE RATE AS WELL AS ALL APPLICABLE FRINGES

NRS 338.010(21) “Wages” means:

- (a) The basic hourly rate of pay; and
- (b) The amount of pension, health and welfare, vacation and holiday pay, the cost of apprenticeship training or other similar programs or other bona fide fringe benefits which are a benefit to the workman.

NRS 338.035 Discharge of part of obligation of contractor or subcontractor engaged on public work to pay wages by making certain contributions in name of workman. The obligation of a contractor engaged on a public work or a subcontractor engaged on a public work to pay wages in accordance with the determination of the Labor Commissioner may be discharged in part by making contributions to a third person pursuant to a fund, plan or program in the name of the workman.

CRAFT

RATE

AIR BALANCE TECHNICIAN

[ADD SHEET METAL ZONE RATE](#)

Air Balance Technician-Journeyman	52.68
Air Balance Technician-Foreman	55.55
Air Balance Technician-General Foreman	58.42

ALARM INSTALLER

Alarm Installer	26.92
-----------------	-------

BOILERMAKER

Boilermaker	65.94
-------------	-------

BRICKLAYER

[ADD ZONE RATE](#)

Bricklayer-Journeyman	33.70
Bricklayer-Foreman	34.95
Bricklayer-General Foreman	36.70

CARPENTER

[ADD ZONE RATE](#)

Carpenter-Journeyman	40.27
Carpenter-Foreman	43.02

CEMENT MASON

[ADD ZONE RATE](#)

Cement Mason-Journeyman	35.75
Cement Mason-Foreman	38.00

**ELECTRICIAN-COMMUNICATION
TECHNICIAN**

[ADD ZONE RATE](#)

Communication Installer	32.40
Communication Technician	35.86
Senior Technician	38.53

ELECTRICIAN-LINE

Electrician-Groundman	45.49
Electrician-Lineman	67.18
Electrician-Foreman	73.02
Electrician-General Foreman	78.90

2014-2015 Prevailing Wage Rates – Washoe County

Heavy Equipment Operator	55.58
ELECTRICIAN-NEON SIGN	
Electrician-Neon Sign	47.28
ELECTRICIAN-WIREMAN	<u>ADD ZONE RATE</u>
Wireman	52.65
Cable Splicer	56.56
Wireman-Foreman	56.56
Wireman-General Foreman	60.48
ELEVATOR CONSTRUCTOR	
Elevator Constructor-Journeyman Mechanic	87.91
Elevator Constructor-Mechanic in Charge	95.74
FENCE ERECTOR	
Fence Erector	16.99
FLAGPERSON	<u>ADD LABORER ZONE RATE</u>
Flagperson	29.24
FLOOR COVERER	
Floor Coverer-Journeyman	37.44
Floor Coverer-Foreman	40.02
GLAZIER	
Glazier Journeyman	19.97
HIGHWAY STRIPER	<u>ADD LABORER ZONE RATE</u>
Highway Striper	35.36
HOD CARRIER-BRICK MASON TENDER	<u>ADD ZONE RATE</u>
Brick Mason-Journeyman	30.82
Brick Mason-Foreman	31.32
HOD CARRIER-PLASTERER TENDER	<u>ADD ZONE RATE</u>
Plasterer Tender-Journeyman	35.36
Plasterer Tender-Gun Tender	36.36

2014-2015 Prevailing Wage Rates – Washoe County

Plasterer Tender-Foreman 36.72

IRON WORKER

Ironworker-Journeyman 60.30

Ironworker-Foreman 63.65

Ironworker-General Foreman 67.34

LABORER

[ADD ZONE RATE](#)

SEE [GROUP CLASSIFICATIONS](#)

Landscaper 26.95

Furniture Mover 28.25

Group 1 32.11

Group 1A 29.24

Group 2 32.21

Group 3 32.36

Group 4 32.61

Group 4A 33.86

Group 5 32.91

Group 6

Nozzlemen, Rodmen 32.91

Gunmen, Materialmen 32.61

Reboundmen 32.36

Gunite Foremen 33.31

MECHANICAL INSULATOR

[ADD ZONE RATE](#)

Mechanical Insulator-Mechanic 58.21

Mechanical Insulator-Foreman 60.71

Mechanical Insulator-General Foreman 62.21

MILLWRIGHT

[ADD ZONE RATE](#)

Millwright 54.76

OPERATING ENGINEER

[ADD ZONE RATE](#)

SEE [GROUP CLASSIFICATIONS](#)

Group 1 46.24

Group 1A 49.00

Group 2 49.53

Group 3 49.80

Group 4 50.54

2014-2015 Prevailing Wage Rates – Washoe County

Group 5	50.84
Group 6	51.01
Group 7	51.26
Group 8	51.85
Group 9	52.17
Group 10	52.52
Group 10A	52.71
Group 11	52.95
Group 11A	54.59
Group 11B	55.40
Foreman	54.59

Add 7% to base rate for "Second" Shift

Add 12.5% to base rate for "Special" shift

**OPERATING ENGINEER-STEEL
FABRICATOR & ERECTOR
SEE [GROUP CLASSIFICATIONS](#)**

[ADD ZONE RATE](#)

Group 1	61.54
Group 1 Truck Crane Oiler	55.37
Group 1 Oiler	53.20
Group 2	60.03
Group 2 Truck Crane Oiler	55.12
Group 2 Oiler	53.20
Group 3	58.29
Group 3 Truck Crane Oiler	54.90
Group 3 Oiler	52.98
Group 3 Hydraulic	54.57
Group 4	57.06
Group 5	55.96

Add 7% to base rate for "Second" Shift

Add 12.5% to base rate for "Special" Shift

**OPERATING ENGINEER -PILEDRIIVER
SEE [GROUP CLASSIFICATIONS](#)**

[ADD ZONE RATE](#)

Group 1	61.01
---------	-------

2014-2015 Prevailing Wage Rates – Washoe County

Group 1 Truck Crane Oiler	55.55
Group 1 Oiler	53.63
Group 2	59.47
Group 2 Truck Crane Oiler	55.37
Group 2 Oiler	53.43
Group 3	58.02
Group 3 Truck Crane Oiler	55.12
Group 3 Oiler	53.20
Group 4	56.51
Group 5	55.40
Group 6	54.29
Group 7	53.33
Group 8	52.37
Add 7% to base for "Second" Shift	-
Add 12.5% to base for "Special" Shift	-

PAINTER

Brush/Roller Painter	33.49
Spray Painter/Paperhanger	34.34
Sandblaster	34.38
Structural Steel & Steeplejack	35.34
Swing Stage	36.34
Special Coating Application-Brush	34.84
Special Coating Application-Spray	35.34
Special Coating Application-Spray Steel	35.56
Foreman	\$1.00 above highest Journeyman

PILEDRIVER

Piledriver-Journeyman	53.96
Piledriver-Foreman	54.96

PLASTERER

[ADD ZONE RATES](#)

Plasterer - Journeyman	36.87
Plasterer - Foreman	39.12

2014-2015 Prevailing Wage Rates – Washoe County

PLUMBER/PIPEFITTER

Plumber/Pipefitter-Journeyman	47.10
Plumber/Pipefitter-Foreman	50.19
Plumber/Pipefitter-General Foreman	53.28

REFRIGERATION

Refrigeration	44.95
---------------	-------

ROOFER (Does not include sheet metal roofs)

Roofer	22.34
--------	-------

SHEET METAL WORKER

[ADD ZONE RATE](#)

Sheet Metal Worker-Journeyman	52.68
Sheet Metal Worker-Foreman	55.55
Sheet Metal Worker-General Foreman	58.42

SPRINKLER FITTER

Sprinkler Fitter -Journeyman	43.33
------------------------------	-------

SURVEYOR

[ADD ZONE RATE](#)

Surveyor	49.80
----------	-------

TAPER

Taper	38.98
-------	-------

**TILE SETTER/TERRAZZO
WORKER/MARBLE MASON-FINISHER**

Tile, Terrazzo and Marble Finisher – Journeyman	25.93
Tile, Terrazzo and Marble Finisher –Foreman	27.18
Tile, Terrazzo and Marble Finisher –General Foreman	28.93

**TILE SETTER/TERRAZZO
WORKER/MARBLE MASON**

[ADD ZONE RATE](#)

Tile Setter-Journeyman	34.13
Tile Setter-Foreman	35.38
Tile Setter-General Foreman	37.13
Terrazzo/Marble Mason-Journeyman	35.63
Terrazzo/Marble Mason-Foreman	35.88

2014-2015 Prevailing Wage Rates – Washoe County

Terrazzo/Marble Mason-General Foreman 37.63

TRAFFIC BARRIER ERECTOR

ADD LABORER ZONE RATE

Traffic Barrier Erector 32.11

TRUCK DRIVER

Dump Trucks (Single or Multiple Units Including Semi's & Double Transfer Units), Dumpcretes and Bulk Cement Spreader 20.47

Under 4 yds. (water level) 20.47

4 yds. & under 8 yds. (water level) 20.47

8 yds. & under 18 yds. (water level) 20.47

18 yds. & under 25 yds. (water level) 20.47

25 yds. & under 60 yds. (water level) 20.47

60 yds. & under 75 yds. (water level) 20.47

75 yds. & under 100 yds. (water level) 20.47

100 yds. & under 150 yds.(water level) 20.47

150 yds. & under 250 yds. (water level) 20.47

250 yds. & under 350 yds. (water level) 20.47

350 yds. & over (water level) 20.47

Transit Mix

Under 8 yds. 20.47

8 yds. & including 12 yds. 20.47

Over 12 yds. 20.47

Transit Mix (Using Boom)

Transit mix with boom shall receive 16 cents per hour above the appropriate yardage classification rate of pay when such boom is used 20.47

Water & Jetting Trucks

Up to 2,500 gallons 20.47

2,500 gallons & over 20.47

DW 20's & 21's & other similar Cat type, Terry Cobra LeTourneau pulls, Tournerocker, Euclid, & similar type equipment when pulling Aqua/Pak, Water Tank Trailers, & Fuel, and/or 20.47

2014-2015 Prevailing Wage Rates – Washoe County

Grease Tank Trailer, or other miscellaneous Trailers, (except as defined under "Dump Trucks")

Heavy Duty Transport (High Bed) 20.47

Heavy Duty Transport(Gooseneck low bed) 20.47

Tiltbed or Flatbed Pull Trailers 20.47

Bootman, Comb. Bootman & Road Oiler 20.47

Flat Rack (2 or 3 axle unit) 20.47

Bus & Manhaul Drivers

Up to 18,000 lbs. (single unit) 20.47

18,000 lbs. & over (single unit) 20.47

Helicopter Pilot (transporting men/materials) 20.47

Lift Jitneys 20.47

Winch Truck & "A" Frame Drivers

Up to 18,000 lbs. 20.47

18,000 lbs. and over 20.47

Warehousemen Spotter 20.47

Warehouse Clerk 20.47

Tire Repairmen 20.47

Truck Repairmen 20.47

Pick Up Truck & Pilot Cars (Jobsite) 20.47

Pick Up Truck & Pilot Cars (Over the road) 20.47

Truck Oil Greaser 20.47

Fuel Truck Driver 20.47

Fuel Man & Fuel Island Man 20.47

Oil Tanker 20.47

Oil Tanker with Pup 20.47

Foreman: 20.47

WELL DRILLER

Well Driller 64.84

LUBRICATION AND SERVICE ENGINEER (MOBILE AND GREASE RACK)

[ADD OPERATING ENG. ZONE RATE](#)

Lubrication and Service Engineer (mobile and grease rack) 51.01

2014-2015 Prevailing Wage Rates – Washoe County

SOIL TESTER (CERTIFIED)

Soil Tester (Certified) 38.90

SOILS AND MATERIALS TESTER

Soils and Materials Tester 38.90

Job Descriptions for Recognized Classes of Workmen

Regarding job descriptions for public works projects, please take notice of the following:

1. Pursuant to NAC 338.0095(1)(a), "A workman employed on a public work must be paid based on the type of work that the workman actually performs on the public work and in accordance with the recognized class of the workman."
2. The work description for a particular class is not intended to be jurisdictional in scope nor to be construed as limiting or prohibiting any worker from performing the work of one or more classes.
3. Any person who believes that a type of work is not classified, or who otherwise needs clarification pertaining to the recognized classes or job descriptions, shall contact the Labor Commissioner, in writing, for a determination of the applicable classification and pay rate for a particular type of work.
4. The job descriptions set forth or referenced herein supersede any and all descriptions previously agreed upon by the Labor Commissioner in any settlement agreements or stipulations arising out of contested matters.
5. The following specific provisions, where applicable, shall prevail over any general provisions of the job descriptions:
 - Amendments to the prevailing wage determinations;
 - Group Classifications and/or descriptions recognized by the Labor Commissioner and included with wage determinations for a particular type of work in a particular county.

AIR BALANCE TECHNICIAN, includes but is not limited to:

Inspecting, testing, programming, documenting, adjusting and balancing heating, cooling and ventilating systems using specialized tools and testing equipment to attain performance standards specified in the design of the systems.

ALARM INSTALLER, includes but is not limited to:

1. Installing or testing electrical protective signaling systems used to provide notification of fire, burglary or other irregularities on the premises of the subscriber of the system;
2. Installing of wiring and signaling units;
3. Repairing electrical protective signaling systems
4. Starting up, programming and documenting systems;

BOILERMAKER, includes but is not limited to:

1. Constructing, assembling, maintaining and repairing stationary steam boilers and boiler house auxiliaries;
2. Aligning structures or plate sections to assemble boiler frame tanks or vats;

2014-2015 Prevailing Wage Rates – Washoe County

3. Assisting in the testing of assembled vessels, directing cleaning of boilers and boiler furnaces;
4. Inspecting and repairing boiler fittings, including, without limitation, safety valves, regulators, automatic-control mechanisms, water columns and auxiliary machines.

BRICKLAYER, includes but is not limited to:

1. Laying materials, including without limitation, brick, structural tile and blocks of concrete, cinder, glass, gypsum and terra cotta, but not including stone, to construct or repair walls, partitions, arches, sewers, and other structures;
2. Laying and aligning bricks, blocks or tiles to build or repair structures for high temperature equipment, including, without limitation, cupola, kilns, ovens and furnaces; and
3. Fastening or fusing brick or other building materials to structures with wire clamps, anchor holes, torches or cement.
4. Pointing-cleaning-caulking of all types of masonry; caulking of window frames encased in masonry on brick, stone or cement structures, including grinding and cutting out on such work and sand blasting, steam cleaning and gunite work.
5. Pointing, cleaning and weatherproofing of buildings, grain elevators and chimneys built of stone, brick or concrete, including grinding and cutting out, sand blasting and gunite work on the same.

CARPENTER, includes but is not limited to:

1. Laying out, constructing, erecting, fabricating, installing and repairing structures and fixtures of wood, plywood, or alternative materials, doors and hardware and the fastening of the same, inclusive of garage or overhead door openers, cabinets, framework, floors, and acoustical ceiling systems using carpenter's hand tools and power tools;
2. Installing or erecting metal studs, drywall, lathing, wall partitions, prefabricated EFIS panels or any other system of panels that is attached to the interior or exterior of any building or structure, insulation and all types of ceilings;
3. Pre-cast concrete and concrete form work which includes but is not limited to: setting of templates, layout, fabrication, constructing, placing, erection, rigging and hoisting, stripping and removing of all forms which are to be reused;
4. Plywood decking, including, without limitation, stacking and installation of the plywood and the plywood decking;
5. Cutting, setting, removing of beam sides and soffits, bracing, and pads;
6. Constructing all wood panel forms and frame wall;
7. Building, erecting and disassembling self-supporting scaffolds that are more than 14 feet in height;
8. Laying out, cutting, joining, fitting of Foam Architectural Elements if same are attached mechanically; and
9. Shaping, cutting and planing by any means if done by hand or machine.

CEMENT MASON, includes but is not limited to:

2014-2015 Prevailing Wage Rates – Washoe County

1. Smoothing and finishing surfaces of poured concrete floors, walls, sidewalks and curbs to specified textures;
2. Patching holes with fresh concrete or an epoxy compound;
3. Molding expansion joints and edges through the use of edging tools, jointers and straightedges;
4. Setting of curb and gutter forms one board high;

ELECTRONIC COMMUNICATION TECHNICIAN, includes but is not limited to:

1. Pulling cable, installing and trimming devices, terminating loops, circuits, or other data gathering points;
2. Termination of main control panels, racks, or other head end equipment, as well as testing of all circuits from the field devices to the main control panels and/or equipment;
3. Utilizing test equipment for the purpose of troubleshooting and verifying the integrity of the circuits in question;
4. Using hand tools to assemble and install data communication lines and equipment computer systems, antennas and towers;
5. Disassembling equipment to adjust, repair or replace parts using hand tools;
6. Starting up, programming and documenting systems;
7. Measuring, cutting, splicing, connecting, soldering and installing wire and cable associated with communication systems

ELECTRICIAN LINEMAN, includes but is not limited to:

1. Erecting and repairing wood poles and prefabricated light duty metal towers, cable and related equipment to construct overhead transmission and distribution power lines used to conduct electrical energy between generating stations, substations and consumers;
2. Directing and assisting electrician ground men in attaching cross arms, insulators, lightning arresters, switches, wire conductors and auxiliary equipment to poles and towers in preparation of erecting the poles or towers;
3. Climbing erected poles or towers and installing equipment such as transformers
4. Strings wire conductors between erected poles with assistance of ground helpers and adjusts slack in conductors to compensate for contraction and elongation of conductors due to temperature variations, using winch.

ELECTRICIAN GROUNDMAN, includes but is not limited to:

1. Working under the direct supervision of linemen, including the operation of jackhammers and man hauls;
2. Loading and unloading of materials and equipment used by electrician lineman.
3. Does not include climbing poles, towers or other structures or working in the proximity of energized lines or equipment;

ELECTRICIAN-NEON SIGN, includes but is not limited to:

1. Installing, servicing and repairing plastic, neon and illuminated signs;

2014-2015 Prevailing Wage Rates – Washoe County

2. Ascending ladders or operating hydraulic or electric hoist to install, service, or examine sign to determine cause of malfunction;
3. Wiring, rewiring or removing defective parts and installing new parts using electrician's tools;
4. Removing sign or part of sign for repairs, such as structural fabrication, scroll repair, or transformer repair;

ELECTRICIAN WIREMAN, includes but is not limited to:

1. Laying out plans, installing, testing and repairing wiring, electrical fixtures, apparatus and control equipment;
2. Measuring, cutting, bending, threading, assembling and installing electrical conduit by using tools including, without limitation, a hacksaw, pipe threader, or conduit bender;
3. Pulling wiring through conduit;
4. Splicing wires;
5. Connecting wiring to lighting fixtures and power equipment;
6. Installing control and distribution apparatus, including, without limitation, switches, relays and circuit breakers, and fastening such apparatus into place;
7. Connecting power cables to equipment, including, without limitation, electric ranges and motors, and installing grounding leads;
8. Testing the continuity of a circuit to ensure electrical compatibility and safety of components using testing instruments, including, without limitation, an ohmmeter, a battery and buzzer, and an oscilloscope;
9. As necessary, cutting and welding steel structural members;

ELEVATOR CONSTRUCTOR, includes but is not limited to:

1. Assembling, installing, repairing and maintaining electric and hydraulic freight and passenger elevators, escalators and dumbwaiters;
2. Cutting pre-fabricated sections of framework, rails and other elevator components to specified dimensions, using acetylene torch, power saw, and disc grinder;
3. Installing cables, counterweights, pumps, motor foundations, escalator drives, guide rails, elevator cars, and control panels, using hand tools;

FENCE ERECTOR, includes but is not limited to:

1. Erecting or repairing chain link, wooden, tortoise, wire/wire mesh, or temporary fencing;
2. Mixing and pouring concrete around bases of posts and tamping soil into post hole to embed post;
3. Digging post holes with a spade, post hole digger or power driven auger;
4. Aligning posts through the use of lines or by sighting;
5. Verifying vertical alignment of posts with a plumb bob or spirit level;

FLAG PERSON, includes but is not limited to:

1. Directing movement of vehicular traffic through construction projects;
2. Distributing traffic control signs and markers along site in designated pattern;

2014-2015 Prevailing Wage Rates – Washoe County

3. Informing drivers of detour routes through construction sites;

FLOOR COVERER, includes but is not limited to:

1. Applying blocks, strips or sheets of shock-absorbing, sound-deadening or decorative covering to floors and walls, including carpets or rugs;
2. Measuring and cutting covering materials, such as rubber, linoleum, astro-turf, or cork tile and foundation material such as felt, using rule, straightedge, linoleum knife and snips;
3. Spreading adhesive cement over floor to cement foundation material to floor for sound-deadening, and to prevent covering from wearing at the board joints;
4. Rolling finished floors to smooth the floor and press cement into base and covering;
5. Fitting of devices for the attachment of carpet, linoleum, rubber and all resilient floor coverings and the fitting of metal edges, corners and caps used in the installation of the foregoing materials and all other preparatory work;

GLAZIER, includes but is not limited to:

1. Installing, setting, cutting, preparing, or removal of glass, or materials used in lieu thereof, including, without limitation, in windows, doorways, showers, bathtubs, skylights and display cases;
2. Installing glass on surfaces, including, without limitation, fronts of buildings, interior walls and ceilings;
3. Installing pre-assembled framework for windows and doors designed to be fitted with glass panels, including stained glass windows by using hand tools;
4. Loading and arranging of glass on trucks at the site of the public work;

HIGHWAY STRIPER, includes but is not limited to:

1. Painting highways, streets and parking surfaces by using manually propelled or mechanically propelled machines, brushes, rollers or spray guns;
2. Installing any device or application of any material used in lieu of paint for traffic direction, including, without limitation, buttons, tapes, plastics, rumble bars and other similar materials;

HOD CARRIER-BRICK MASON TENDER, includes but is not limited to:

1. Tending to or assisting brick masons, bricklayers and stonemasons;
2. Mixing, packing, wheeling and tempering mortar and fire clay;
3. Mixing, supplying and holding materials or tools;
4. Mixing, handling and conveying all other materials used by brick masons, bricklayers and stone masons;
5. Building scaffolds, trestles, boxes and swinging staging used exclusively by bricklayers and stone masons;
6. Hanging cables and placing putlogs;
7. Carrying bricks and mortar in a hod;
8. Cleaning work area and equipment of bricklayers and stone masons

2014-2015 Prevailing Wage Rates – Washoe County

HOD CARRIER-PLASTERER TENDER, includes but is not limited to:

1. Serving Plasterers in any capacity;
2. Handling materials after the materials are delivered as used by a Plasterer;
3. Building and handling all necessary trestle, scaffolding and planking of scaffolding for the exclusive use of Plasterers;
4. Building mortar boxes, mortar boards and stands.

IRONWORKER, includes but is not limited to:

1. Performing duties, as part of a crew, to raise, place and unite girders, columns and other structural steel members to form completed structures or structure frameworks;
2. Setting up hoisting equipment for raising and placing structural steel members;
3. Fastening steel members to cable of hoist, using chains, cable or rope;
4. Forcing steel members into final position using turnbuckles, crowbars, jacks, hand tools;
5. Aligning rivet holes in steel members with corresponding holes in previously placed steel members by driving drift pins to handle of wrench through holes;
6. Bolting aligned steel members to keep them in position until the steel members can be permanently riveted, bolted or welded into place;
7. Cutting and welding steel members;
8. Installing and repairing gates, iron doors, flagpoles, iron fences and roof decking;
9. Installing corrugated sheets when attached to steel frames;
10. Stud welding of all iron, steel and metal to structural steel;
11. Handling and setting of steel and metal joists;
12. Loading, unloading, hoisting, handling, signaling, placing and erecting of pre-stressed and pre-cast materials;
13. Handling, racking, sorting, cutting, bending, hoisting, placing, burning, welding and tying all material used to reinforce concrete construction;

LABORER, includes but is not limited to:

Perform tasks involving physical labor at building, highway, and heavy construction projects, tunnel and shaft excavations, and demolition sites. May operate hand and power tools of all types: air hammers, earth tampers, cement mixers, small mechanical hoists, and a variety of other equipment and instruments. May clean and prepare sites, dig trenches, set braces to support the sides of excavations, erect scaffolding, clean up rubble and debris, and remove asbestos, lead, and other hazardous waste materials. May assist other craft workers.

MARBLE MASON, includes but is not limited to:

1. Cutting, tooling, and setting marble slabs in floors and walls of buildings and renovating and polishing marble slabs previously set in buildings;
2. Trimming, facing and cutting marble to a specific size using a power saw, cutting and facing equipment, and hand tools
3. Drilling holes in marble slabs and attaching brackets;
4. Spreading mortar on the bottom and sides of a marble slab and on the side of adjacent marble slabs;

2014-2015 Prevailing Wage Rates – Washoe County

5. Setting blocks in positions, tamping a marble slab into place and anchoring bracket attachments with wire;
6. Filling joints between marble slabs with grout and removing excess grout with a sponge;
7. Cleaning and beveling cracks and chips on marble slabs using hand tools and power tools;
8. Heating cracked or chipped areas of a marble slab with a blowtorch and filling the defect with a composition mastic that matches the grain of the marble slab; and
9. Polishing marble slabs and other ornamental stone to a high luster by using hand tools and power tools.

MECHANICAL INSULATOR, includes but is not limited to:

1. Covering and lining structures with cork, canvas, tar paper, magnesia and related materials;
2. Installing blown-on insulation on pipe and machinery;
3. Lining of mechanical room surfaces and air handling shafts;
4. Filling and damming of fire stops and penetrations including, but not limited to, electrical and mechanical systems;
5. Foam applications for the purpose of thermal, acoustical, or fire protective purposes, including RTV foams or equivalents, applied to mechanical or electrical systems;
6. Duct lining and duct wrapping, direct application and installation of fire protection of grease ducts, exhaust systems, or any other ductwork for acoustical or thermal purposes;
7. Insulation of field joints on pre-insulated underground piping and the pouring of Gilsilite or its equivalent;
8. The application of material, including metal and PVC jacketing, on piping, fittings, valves, flanges, boilers, ducts, plenums, flues, tanks, vats, equipment and any other hot or cold surface for the purpose of thermal control;

MILLWRIGHT, includes but is not limited to:

1. Installing machinery and equipment according to layout plans, blueprints and other drawings in industrial establishments by using hoists, lift trucks, hand tools and power tools;
2. Dismantling machines by using hammers, wrenches, crowbars and other hand tools;
3. Assembling and installing equipment, including, without limitation, shafting, conveyors, monorails and tram rails, by using hand tools and power tools;
4. Constructing foundations for machines by using hand tools and building materials, including, without limitation, wood, cement and steel;
5. Assembling machines and bolting, welding, riveting or otherwise fastening them to a foundation or other structure by using hand tools and power tools; and
6. Repairing and lubricating machines and equipment (at the site of the public work) assembled and used by millwrights.

OPERATING ENGINEER, includes but is not limited to:

Operate one or several types of power construction equipment, such as motor graders, bulldozers, scrapers, compressors, pumps, derricks, shovels, tractors, or front-end loaders to

2014-2015 Prevailing Wage Rates – Washoe County

excavate, move, and grade earth, erect structures, or pour concrete or other hard surface pavement.

PAINTER, includes but is not limited to:

1. All painting of walls, equipment, buildings, bridges and other structural surfaces by using brushes, rollers and spray guns;
2. Application of wall coverings/wall paper;
3. Removing old paint to prepare surfaces before painting the surface;
4. Mixing colors or oils to obtain desired color or consistency;
5. Sanding surfaces between coats and polishing final coat to a specified finish;
6. Cutting stencils and brushing and spraying lettering and decorations on surfaces;
7. Washing and treating surfaces with oil, turpentine, mildew remover or other preparations;
8. Filling cracks, holes and joints with caulk, putty, plaster or other filler by using caulking gun or putty knife;

PILEDRIVER, includes but is not limited to:

1. Operating pile drivers mounted on skids, barge, crawler, treads or locomotive crane to drive piling as foundations for structures including, without limitation, buildings, bridges and piers;
2. Barking, shoeing, splicing, form building, heading, centering, placing, driving, staying, framing, fastening, automatic pile threading, pulling and/or cutting off of piling;
3. Fabricating, forming, handling and setting of all such pre-cast, pre-stressed and post-stressed shapes that are an integral part of docks, piers, wharves, bulkheads, jetties, and similar structures;

PIPEFITTER, includes but is not limited to:

Assembling, installing, modifying and maintaining pipe systems, pipe supports and pneumatic equipment and related machines and equipment components for steam, hot water, heating, cooling, lubricating, sprinkling and industrial and processing systems which may require:

- a. Cutting, threading and hammering pipe to specifications using tools, including, without limitation, saws, cutting torches and pipe threaders and benders;
- b. Attaching pipes to walls, structures and fixtures, including without limitation, radiators or tanks, using brackets, clamps, tools, or welding equipment;
- c. Coating non-ferrous piping materials by dipping in mixture of molten tin and lead to prevent erosion, or galvanic and electrolytic action;

PLASTERER, includes but is not limited to:

1. Applying coats of plaster onto interior or exterior walls, ceilings, or partitions of buildings to produce a finished surface according to blueprints, architects' drawings and oral instruction;
2. Creating decorative textures in finish coat by using sand, pebbles or stones;

2014-2015 Prevailing Wage Rates – Washoe County

3. Installing guide wires on exterior surfaces of buildings to indicate thickness of plaster or stucco;
4. Applying weatherproof, decorative covering to exterior surfaces of a building;
5. Molding and installing ornamental plaster pieces, panels and trim;
6. Directing workers to mix plaster to a desired consistency;
7. Assembly of EFIS panels;
8. Laying out, cutting, joining, fitting and installation of Architectural Foam Elements which are trowel applied or adhesive set;
9. Applying, shaping, cutting, and planing in preparation for netting done by hand or machine;
10. All plaster or synthetic finishes applied to Foam Architectural Elements

PLUMBER, includes but is not limited to:

Assembling, installing and repairing pipes, fittings and fixtures for heating, water and drainage systems inside of buildings and to a point 5 feet outside of buildings which may therein require:

- a. Repairing and maintaining plumbing by replacing defective washers, repairing or mending broken pipes, and opening clogged drains;
- b. Assembling pipe sections, tubing and fittings by using screws, bolts, solder, plastic solvent and caulking;
- c. Installing pipe assemblies, fittings, valves and fixtures, including, without limitation, sinks, toilets and tubs, by using hand tools and power tools;
- d. Cutting openings in structures, excluding concrete, to accommodate pipe and pipe fittings by using hand tools and power tools;
- e. Filling pipes and plumbing fixtures with water or air and observing pressure gauges to detect and locate leaks.

REFRIGERATION MECHANIC, includes but is not limited to:

1. Installing and repairing industrial and commercial refrigeration systems;
2. Mounting compressors, condensers and other refrigeration components to the frame of a refrigerator by using hand tools and acetylene welding equipment;
3. Assembling structural and functional components needed for refrigeration, including, without limitation, controls, switches, gauges, wiring harnesses, valves, pumps, compressors, condensers, cores and pipes;
4. Installing expansion and control valves by using hand tools and acetylene welding equipment;
5. Cutting, bending, threading and connecting pipe from functional components to water, power or refrigeration systems;
6. Fabricating and assembling components and structural portions of a refrigeration system;

ROOFER, includes but is not limited to:

1. Installing and covering roofs and structures with slate, asphalt, wood and other related materials, other than sheet metal, by using brushes, knives, punches, hammers and other tools;

2014-2015 Prevailing Wage Rates – Washoe County

2. Spraying roofs, sidings and walls with material to bind, seal, insulate or soundproof sections of a structure;
3. Installation of all plastic, slate, slag, gravel, asphalt and composition roofing, and rock asphalt mastic when used for damp and waterproofing;
4. Installation of all damp resisting preparations when applied on roofs with mop, three-knot brush, roller, swab or spray system;
5. All types of preformed panels used in waterproofing;
6. Handling, hoisting and storing of all roofing, damp and waterproofing materials;
7. The tear-off and/or removal of roofing and roofing materials;

SHEET METAL WORKER, includes but is not limited to:

1. Fabricating, assembling, dismantling, installing or repairing:
 - Sheet metal roofs, including #30 felt roofing paper installed to form a metal roofing system;
 - Sheet metal parts or equipment, including, without limitation, duct work, metal lockers and kitchen equipment;
 - Air-veyor and air-handling systems, regardless of materials used;
2. Setting up and operating fabrication machines to cut, bend and straighten sheet metal;
3. Shaping metal over anvils, blocks or forms using a hammer;
4. Operating soldering and welding equipment to join sheet metal parts;
5. Inspecting, assembling and smoothing seams and joints of burred surfaces;
6. Welding, soldering, bolting, riveting, screwing, clipping, caulking or bonding component parts to assemble products by using hand tools, power tools and devices for lifting and handling;

SPRINKLER FITTER, includes but is not limited to:

Installing, dismantling, maintaining, repairing, adjusting and correcting all fire protection and fire control systems, including the installation of piping or tubing, appurtenances and equipment pertaining thereto, including both overhead and underground water mains, fire hydrants, and hydrant mains, standpipes and hose connection to sprinkler systems, sprinkler tank heaters, air lines and thermal systems used in connection with sprinkler and alarm systems.

SURVEYOR, includes but is not limited to:

1. Planning ground surveys designed to establish base lines, elevation and other geodetic measurements;
2. Compiling data relevant to the shape, contour, gravitation, location, elevation and dimension of land and land features on or near the surface of the Earth for engineering, map making, mining, land evaluation, construction and other purposes;
3. Surveying bodies of water to determine navigable channels and to secure data for construction of breakwaters, piers and other marine structures;
4. Computing data necessary for driving and connecting underground passages, underground storage and volume of underground deposits.

TAPER, includes but is not limited to:

2014-2015 Prevailing Wage Rates – Washoe County

1. Sealing joints between plasterboard or other wallboards to prepare a wall surface for painting or papering;
2. Mixing sealing compound by hand or with a portable electric mixer and spreading the compound over the joints between boards using a trowel, broad knife, or spatula;
3. Filling cracks and holes in walls and ceilings with sealing compound ;
4. Applying texturing compound and primer to walls and ceiling to prepare a surface for a final finish by using brushes, rollers and spray guns;
5. Coating of joint compound or taping mud;

TERRAZZO WORKER, includes but is not limited to:

1. Applying cement, sand, pigment and marble chips to floors and stairways to attain durable and decorative surfacing according to specifications or drawings;
2. Spreading mixtures of sand, cement and water over surface with a trowel to form terrazzo;
3. Cutting metal division strips and pressing the metal division strips into a terrazzo base so that top edges form a desired design or pattern and define level of finished floor surface;
4. Spreading mixtures of marble chips, cement, pigment and water over a terrazzo base to form a finished surface by using a float and trowel;
5. Pre-casting terrazzo blocks in wooden forms

TILE SETTER, includes but is not limited to:

1. Applying tile and materials made for tile in tile-like units to walls, floors, ceilings and promenade roof decks following design specification;
2. Applying glazed, unglazed, mosaic and other ceramic tiles, which are used as a surface on floors, walls, ceilings, and other surfaces and which must be set to specific grade;
3. Applying and floating all setting beds into which glazed, unglazed, mosaic, or other ceramic tiles are set;
4. Leveling and plumbing tiles to a specified grade

TILE, TERRAZZO AND MARBLE FINISHER, includes but is not limited to:

1. Supplying and mixing construction materials for a tile setter, terrazzo worker or marble setter;
2. Applying grout and finishing the surface of installed tile, terrazzo and marble;
3. Cleaning installed tile, terrazzo and tile surfaces;
4. Renovation and filling chipped, cracked and broken pieces of tile, terrazzo and marble;
5. Grinding and polishing tile, terrazzo and marble;
6. Assisting a tile setter, terrazzo worker or marble setter;

TRAFFIC BARRIER ERECTOR, includes but is not limited to:

Erects or places instruments to provide directional assistance to traffic on or near the public works construction project.

TRUCK DRIVER, includes but is not limited to:

2014-2015 Prevailing Wage Rates – Washoe County

Driving a tractor trailer combination or a truck to transport goods or materials at the site of a public work or between sites of a public work. (Also, see descriptions listed with Truck Driver rates, if any.)

WELL DRILLER, includes but is not limited to:

1. Setting, operating or tending to portable drilling rig machinery and related equipment to drill wells;
 2. Extending stabilizing jackscrews to support and level a drilling rig;
 3. Installing water well pumps;
 4. Drillings wells for industrial water supplies, irrigation water supplies or water supplies for any other purpose; dewatering or other similar purposes; exploration; hole drilling for geologic and hydrologic information; and core drilling for geologic information.
-

GROUP CLASSIFICATIONS

LABORER, includes but is not limited to:

Group 1

All cleanup work of debris, grounds, and building including windows and tile

Dumpmen or Spotter (other than asphalt)
Handling and Servicing of Flares, Watchmen
General Laborer
Guide Posts and Highway Signs
Guardrail Erection and Dismantling
Limber, Brushloader and Piler
Pavement Marking and Highway Striping
Traffic Control Supervisor

Group 2

Choker setter or Rigger (clearing work only) Pittsburgh
Chipper and similar type brush shredders
Concrete worker (wet or dry) all concrete work not listed in Group 3
Crusher or Grizzly Tender
Greasing Dowels
Guinea Chaser (Stakemen)
Panel Forms (wood or metal) handling, cleaning and stripping of Loading and unloading,
(Carrying and handling of all rods and material for use in reinforcing concrete
Railroad Trackmen (maintenance, repair or builders)
Sloper
Semi-Skilled Wrecker (salvaging of building materials other than those listed in Group 3)

Group 3

Asphalt Workers (Ironers, Shovelers, Cutting Machine)
Buggymobile
Chainsaw, Faller, Logloader and Bucker
Compactor (all types)
Concrete Mixer under 1/2 yard
Concrete Pan Work (Breadpan type), handling, cleaning\stripping
Concrete Saw, Chipping, Grinding, Sanding, Vibrator
Cribbing, Shoring, Lagging, Trench Jacking, Hand-Guided Lagging Hammer
Curbing or Divider machine
Curb Setter (precast or cut)
Ditching Machine (hand-guided)
Drillers Helper, Chuck Tender
Form Raiser, Slip Forms
Grouting of Concrete Walls, Windows and Door Jams
Headerboardmen
Jackhammer, Pavement Breaker, Air Spade
Mastic Worker (wet or dry)
Pipewrapper, Kettlemen, Potmen, and men applying asphalt, creosote and similar type

2014-2015 Prevailing Wage Rates – Washoe County

materials

All Power Tools (air, gas, or electric), Post Driver

Riprap-Stonepaver and RockSlinger, including placing of sack concrete wet or dry
Rototiller

Rigging and Signaling in connection with Laborers' work

Sandblaster, Potmen, Gunmen or Nozzlemen

Vibra-screed

Skilled Wrecker (removing and salvaging of sash, windows, doors, plumbing and electrical fixtures)

Group 4

Burning and Welding in connection with Laborers' work

Joy Drill Model TWM-2A, Gardner Denver Model DN143 and similar type drills (in accordance with Memorandum of Understanding between Laborers and Operating Engineers dated at Miami, Florida, Feb. 3, 1954) and Track Drillers, Diamond Core Drillers, Wagon Drillers, Mechanical Drillers on Multiple Units

High scalers

Concrete pump operator

Heavy Duty Vibrator with Stinger 5" diameter or over

Pipelayer, Caulker and Bander

Pipelayer-waterline, Sewerline, Gasoline, Conduit

Cleaning of Utility Lines

Slip Lining of Utility Lines (including operation of Equipment)

TV Monitoring and Grouting of Utility Lines

Asphalt Rakers

Group 4A

Foreman

Group 5

Construction Specialists

Blasters and Powdermen, all work of loading, placing, and blasting of all powder and explosives of any type, regardless of method used for such loading and placing

Asbestos removal

Lead abatement

Hazardous waste

Material removal

Group 6

Gunite Foremen, Nozzlemen, Rodmen, Gunmen, Materialmen, Reboundmen

OPERATING ENGINEER, includes but is not limited to:

Group 1

Engineer Assistant

2014-2015 Prevailing Wage Rates – Washoe County

Group 1A

Heavy Duty Repairman Helper
Oiler
Parts man

Group 2

Compressor Operator
Material Loader and/or Conveyor Operator (handling building materials)
Pump Operator

Group 3

Bobcat or similar loader, 1/4 cu. yd. or less
Concrete Curing Machines (streets, highways, airports, canals)
Conveyor Belt Operator (tunnel)
Forklift (under 20)
Engineer Generating Plant (500 K.W.)
Mixer Box Operator (concrete plant)
Motorman
Rotomist Operator
Oiler (truck crane)

Group 4

Concrete Mixer Operator, Skip type
Dinky Operator
Forklift (20' or over) or Lumber Stacker
Ross Carrier
Skip Loader Operator (under one (1) cu. yd.)
Tie Spacer

Group 5

Concrete Mixers (over one (1) cu. yd.)
Concrete Pumps or Pumpcrete Guns
Elevator and Material Hoist (one (1) drum)
Groundman for Asphalt Milling and similar

Group 6

Auger type drilling equipment up to and including 30 ft. depth digging capacity m.r.c.
Boom Truck or Dual Purpose a-Frame Truck
B.L.H. Lima Road Pactor or similar
Chip Box Spreader (Flaherty type or similar)
Concrete Batch Plant (wet or dry)
Concrete Saws (highways, streets, airports, canals)
Locomotives (over thirty (30) tons)
Maginnis International Full Slab Vibrator (airports, highways, canals and warehouses)
Mechanical Finishers (concrete) (Clary, Johnson, Bidwell Bridge Deck or similar types)
Mechanical Burn, Curb and/or Curb and Gutter Machine (concrete or asphalt)
Pavement Breaker, Truck Mounted, with compressor combination
Pavement Breaker or Tamper (with or without compressor combination)

2014-2015 Prevailing Wage Rates – Washoe County

Power Jumbo Operator (setting slip-forms, etc., in tunnels)
Roller Operator (except asphalt)
Self-Propelled Tape Machine
Self-Propelled Compactor (single engine)
Self-Propelled Power Sweeper Operator
Slip-Form Pump (power-driven by hydraulic, electric, air, gas, etc. lifting device for concrete forms)
Small Rubber-Tired Tractors
Snooper Crane, Paxton-Mitchell or similar
Stationary Pipe Wrapping, Cleaning and Bending Machine Operator

Group 7

Auger type drilling equipment over 30 ft. depth digging capacity m.r.c.
Compressor (over 2)
Concrete Conveyor or Concrete Pump, truck or equipment mounted (any assistance required shall be performed by an Assistant to Engineer) Boom length to apply
Concrete Conveyor, Building Site
Drilling and Boring Machine, vertical and horizontal (not to apply to waterliners, wagon drills or jack hammers)
Crusher Plant Engineer
Generators
Kolman Loader
Material Hoist (two (2) or more drums)
Mechanical Finishers or Spreader Machine (asphalt, Barber-Greene or similar)
Mine or Shaft Hoist
Pipe Bending Machines (pipeline only)
Pipe Cleaning Machines (tractor-propelled and supported)
Pipe Wrapping Machines (tractor-propelled and supported)
Portable Crushing and Screening Plants
Post Driller And/Or Driver
Pumps (over 2)
Roller Operator (asphalt)
Screedman (except asphaltic or concrete paving)
Screedman (Barber-Greene and similar) (asphaltic or concrete paving)
Self-Propelled Boom-Type Lifting Device (center mount) (on ten (10) ton capacity or less)
Slusher Operator
Surface Heater and Planer Operator
Trenching Machine (maximum digging capacity three (3) ft. depth) (Any assistance in the operation, if needed, shall be performed by an Assistant to Engineer)
Truck-Type Loader
Welding Machines (gasoline or diesel)

Group 8

Asphalt Plant Engineer
Asphalt Milling Machine
Cast-In-Place Pipe-Laying Machine
Combination Slusher and Motor Operator
Concrete Batch Plant (multiple units)

2014-2015 Prevailing Wage Rates – Washoe County

Dozer Operator
Drill Doctor
Elevating Grader Operator
Grooving and Grinding Machine (highways)
Ken Seal Operator
Loader (up to and including two and one-half (2 1/2) cu. yds)
Mechanical Trench Shield
Mixermobile
Push Cats
Road Oil Mixing Machine Operator Wood-Mixer (and other similar Pugmill equipment)
Rubber-Tired Earthmoving Equipment (up to and including thirty-five (35) cu. yds. "struck " m.r.c., Euclids, T-Pulls, DW10, 20, 21 and similar)
Self-Propelled Compactors with Dozer; Hyster 450, Cat 825 or similar
Sheepfoot
Small Tractor (with boom)
Soil Stabilizer (P & H or equal)
Timber Skidder (rubber-tired) or similar equipment
Tractor-Drawn Scraper
Tractor Operator
Tractor-Mounted Compressor Drill Combination
Trenching Machine Operator (over three (3) feet depth)
Tri-Batch Paver
Tunnel Badger or Tunnel Boring Machine Operator
Tunnel Mole Boring Machine
Vermeer T-600b Rock Cutter

Group 9

Chicago Boom
Combination Backhoe and Loader (up to and including 3/8 cu. yd.)
Combination Mixer and Compressor (gunite)
Heavy Duty Repairman and/or Welder
Lull Hi-Lift (twenty (20) feet or over)
Mucking Machine
Sub-Grader (Gurries or other types)
Tractor (with Boom) (D6 or larger)
Track-Laying-Type Earthmoving Machine (single engine with tandem scrapers)

Group 10

Boom-Type Backfilling Machine
Bridge Crane
Cary-Lift or similar
Chemical Grouting Machine
Derricks (two (2) Group 10 Operators required when swing engine remote from hoist)
Derrick Barges (except excavation work)
Euclid Loader and similar types
Gradesetter, Grade Checker
Heavy Duty Rotary Drill Rigs

2014-2015 Prevailing Wage Rates – Washoe County

Lift-Slab (Vagtborg and similar types)
Loader (over two and one-half (2 1/2 cu. yds. up to and including four (4) cu. yds.)
Locomotive (over one hundred (100) tons, single or multiple units)
Multiple-Engine Earthmoving Machines (Euclid Dozers, etc.)
Pre-Stress Wire Wrapping Machine
Rubber-Tired Scraper, Self-Loading
Single-Engine Scraper (over thirty-five (35) cu. yds.)
Shuttle Car (Reclaim Station)
Train Loading Station
Trenching Machine multi-engine with sloping attachments (Jefco or similar)
Vacuum Cooling Plant
Whirley Crane (up to and including twenty-five (25) tons)

Group 10A

Backhoe-Hydraulic (up to and including one (1) cu. yd.)
Backhoe (up to and including one (1) cu. yd.) (Cable)
CMI Dual Lane Auto-Grader SP30 or similar type
Cranes (not over twenty-five (25) tons) (hammerhead and gantry)
Finish Blade
Gradalls (up to and including one (1) cu. yd.)
Motor Patrol Operator
Power Shovels, Clamshells, Draglines, Cranes (up to and including one (1) cu. yd.)
Rubber-Tired Scraper, Self-Loading (twin engine)
Self-Propelled Boom-Type Lifting Device, center mount (over 10 tons up to and including 25 tons)

Group 11

Automatic Asphalt or Concrete Slip-Form Paver
Automatic Railroad Car Dumper
Canal Trimmer
Cary Lift, Campbell or similar type
Cranes (over twenty-five (25) tons)
Euclid Loader when controlled from the Pullcat
Highline Cableway Operator
Loader (over four (4) cu. yds. up to and including twelve (12) cu. yds.)
Multi-Engine Earthmoving Equipment (up to and including seventy-five (75) cu. yds. struck m.r.c.)
Multi-Engine Scrapers (when used to Push Pull)
Power Shovels, Clamshells, Draglines, Backhoes Gradalls (over one (1) cu. yd. and up to and including seven (7) cu. yds. m.r.c.)
Self-Propelled Boom-Type Lifting Device (center mount) (over 25 tons m.r.c.)
Self-Propelled Compactor (with multiple-propulsion power units)
Single-Engine Rubber-Tired Earthmoving Machine, with Tandem Scraper
Slip-Form Paver (concrete or asphalt)
Tandem Cats and Scraper
Tower Crane Mobile (including Rail Mount)
Truck Mounted Hydraulic Crane when remote control equipped (over 10 tons up to and including 25 tons)

2014-2015 Prevailing Wage Rates – Washoe County

Universal Liebherr and Tower Cranes (and similar types)
Wheel Excavator (up to and including seven hundred fifty (750) cu. yds. per hour)
Whirley Cranes (over twenty-five (25) tons)

Group 11A

Band Wagons (in conjunction with Wheel Excavators)
Operator of Helicopter (when used in construction work)
Loader (over twelve (12) cu. yds.)
Multi-Engine Earthmoving Equipment (over seventy-five (75) cu. yds. "struck" m.r.c.)
Power Shovels, Clamshells, Draglines, Backhoes, and Gradalls (over seven (7) cu. yds. m.r.c.)
Remote-Controlled Earth Moving Equipment
Wheel Excavator (over seven hundred fifty (750) cu. yds. per hour)

Group 11B

Holland Loader or similar or Loader (over 18 cu. yds.)

OPERATING ENGINEERS - Steel Fabricator & Erector

Group 1

Cranes over 100 tons
Derrick over 100 tons
Self-Propelled Boom Type Lifting Devices over 100 tons

Group 2

Cranes over 45 tons up to and including 100 tons
Derrick, 100 tons and under
Self Propelled Boom Type Lifting Device, over 45 tons
Tower Crane

Group 3

Cranes, 45 tons and under
Self Propelled Boom Type Lifting Device, 45 tons and under

Group 4

Chicago Boom
Forklift, 10 tons and over
Heavy Duty Repairman/Welder

Group 5

Boom Cat

OPERATING ENGINEER -PILED RIVER

Group 1

Derrick Barge Pedestal mounted over 100 tons
Clamshells over 7 cu. yds.
Self Propelled Boom Type Lifting Device, over 100 tons
Truck Crane or Crawler, land or barge mounted over 100 tons

Group 2

Derrick Barge Pedestal mounted 45 tons up to and including 100 tons
Clamshells up to and including 7 cu. yds.
Self Propelled Boom Type Lifting Device over 45 tons
Truck Crane or Crawler, land or barge mounted, over 45 tons up to and including 100 tons

Group 3

Derrick Barge Pedestal mounted under 45 tons
Self Propelled Boom Type Lifting Device 45 tons and under
Skid/Scow Piledriver, any tonnage
Truck Crane or Crawler, land or barge mounted 45 tons and under

Group 4

Assistant Operator in lieu of Assistant to Engineer
Forklift, 10 tons and over
Heavy Duty Repairman/Welder

Group 5

No current classification

Group 6

Deck Engineer

Group 7

No current classification

Group 8

Deckhand
Fireman

ZONE RATES

BRICKLAYER

In addition to BRICKLAYER rates add the applicable amounts per hour, calculated based on a radius of over thirty five (35) miles from the Washoe County Courthouse in Reno, Nevada:

Zone 1-0-35 Miles	\$0.00
Zone 2-36-75 Miles	\$1.25
Zone 3-Over 75 Miles	\$5.37

CARPENTER (Building and Heavy Highway and Dam Construction)

In addition to CARPENTER rates add the applicable amounts per hour, calculated from the Washoe County Courthouse:

Zone 1-0 to 50 miles	\$0.00 (road miles of either the Carson City Courthouse or the Washoe County Courthouse)
Zone 2-51-150 miles	\$3.00
Zone 3-151-300 miles	\$4.00
Zone 4-301 miles and over	\$5.00

CEMENT MASON

In addition to CEMENT MASON rates add the applicable amounts per hour, calculated from the Reno Post Office, 50 So. Virginia St., Reno, Nevada:

Zone 1-0-90 miles	\$0.00
Zone 2-91 miles and over	\$6.00

ELECTRICIAN

In addition to Electrician rates add the applicable amounts per hour, calculated from the Washoe County Courthouse:

Zone 1-0-70 miles	\$0.00
Zone 2-71-90 miles	\$8.00
Zone 3 -91 miles and over	\$10.00

ELECTRICIAN-COMMUNICATION TECH

In addition to Electrician Communication Tech rates add the applicable amounts per hour, calculated from the Washoe County Courthouse:

Zone 1-0-70 miles	\$0.00
Zone 2-71-90 miles	\$5.00
Zone 3 -91 miles and over	\$7.00

HOD CARRIER-BRICK MASON TENDER

In addition to Hod Carrier Brick Mason Tender rates add the applicable amounts per hour, calculated based on a radius from the Washoe County Courthouse:

Zone 1-35 to 75 miles	\$1.25
Zone 2-76 miles and over	\$7.50

HOD CARRIER-PLASTERER

In addition to Hod Carrier Plasterer rates add the applicable amounts per hour, calculated based on a radius from So. Virginia St., Reno, Nevada:

Zone 1-70 miles	\$0.00
-----------------	--------

2014-2015 Prevailing Wage Rates – Washoe County

Zone 70 miles and over \$8.00

LABORER (Highway and Dam Construction only)

In addition to LABORER rates add the applicable amounts per hour, calculated based on road miles from either the Carson City Courthouse or the Washoe County Courthouse:

Zone 1-0 to 50 miles \$0.00
Zone 2-51 to 150 miles \$3.00
Zone 3-151 to 300 miles \$4.00
Zone 4-301 miles and over \$5.00

LABORER (Building Construction)

In addition to LABORER rates add the applicable amounts per hour, calculated based on road miles from either the Carson City Courthouse or the Washoe County Courthouse:

Zone 1-0 to 50 miles \$0.00
Zone 2-51 to 150 miles \$3.00
Zone 3-151 to 300 miles \$4.00
Zone 4-301 miles and over \$5.00

MECHANICAL INSULATOR

In addition to MECHANICAL INSULATOR rates add the applicable amounts per hour, calculated based on a radius figured from Clark County Courthouse:

Zone 1-20-45 miles- \$3.75
Zone 2-45-75 miles- \$5.00
Zone 3-75-150 miles- \$7.50
Zone 4-150 miles and over- \$8.75

MILLWRIGHT

In addition to MILLWRIGHT rates add the applicable amounts per hour, calculated on road miles from either the Carson City Courthouse or the Washoe County Courthouse:

Zone 1-1 to 15 miles \$0.00
Zone 2-15 to 35 miles \$1.50
Zone 3-35 miles and over \$3.25

OPERATING ENGINEER

In addition to: OPERATING ENGINEER; STEEL FABRICATOR and ERECTOR, PILEDRIVER, SURVEYOR, and LUBRICATION AND SERVICE ENGINEER rates add the applicable amounts per hour calculated based on a radius from the Washoe County Courthouse:

Zone 1-0 to 75 miles \$ 0.00 (of either the Carson City Courthouse or the Washoe County Courthouse)
Zone 2-75 to 150 miles \$3.00
Zone 3-151 to 300 miles \$4.00
Zone 4-301 miles and over \$5.00

PLASTERER

In addition to PLASTERER rates add the applicable amounts per hour, calculated from the South Virginia and Mill Street, Reno, Nevada:

Zone 1-0-70 miles \$0.00
Zone 2-70 miles and over \$8.00

2014-2015 Prevailing Wage Rates – Washoe County

SHEET METAL WORKER

In addition to SHEET METAL WORKER rates, add the applicable amounts per hour, calculated based on a radius from the courthouse in Reno, Nevada:

Zone 1-0 to 100 miles	\$0.00 (including the City of Fallon and the Fallon Naval Air Base)
Zone 2-over 100 miles	\$8.12

TILE SETTER/TERRAZZO WORKER/MARBLE MASON

In addition to TILE SETTER/TERRAZZO WORKER/MARBLE MASON rates add the applicable amounts per hour, calculated based on a radius of over thirty five (35) miles from the Washoe County Courthouse in Reno, Nevada:

Zone 1-0-35 Miles	\$0.00
Zone 2-35-75 Miles	\$1.25
Zone 3-Over 75 Miles	\$5.00

“SAMPLE”
AGREEMENT FOR CONSTRUCTION
Innovation Well and Army Aviation Well Drilling, Construction, Development and Testing
TMWA Capital Project No.: 15-0018
Public Works Project Number: WA-2015-235

THIS AGREEMENT FOR CONSTRUCTION (the “Agreement”), made and entered into this ____ day of _____, 20____, by and between _____ a general contractor licensed by the State of Nevada (Nevada Contractor’s License No. _____) (hereinafter referred to as “Contractor”), and Truckee Meadows Water Authority, P.O. Box 30013, Reno Nevada 89520-3013 (hereinafter referred to as “Owner”).

RECITALS

WHEREAS, Owner intends to construct the Project and is engaging Contractor to perform certain labor, supervision and services and to provide certain equipment, goods and materials for the Project as described herein.

WHEREAS, Owner has engaged Contractor based on Contractor’s representations that it (i) is experienced in the type of work for which it is being engaged; (ii) is duly licensed and qualified in the State of Nevada to perform the type of work for which it is being engaged; (iii) is qualified, willing and able to perform the work for the Project; and (iv) has the expertise and capability to perform the work which will meet Owner’s objectives and which will comply with all applicable laws and ordinances.

WHEREAS, Contractor acknowledges it has reviewed and familiarized itself with this Agreement, including the documents enumerated in Article 1, and agrees to be bound by the terms and conditions contained therein.

NOW, THEREFORE, for good and valuable consideration, receipt of which is acknowledged, TMWA and the Contractor agree as follows:

1. CONTRACT DOCUMENTS. The “Contract Documents” consist solely of the Bidding Documents, Bonds, this Agreement, the General Conditions, Supplementary Conditions, Special, Water Supply Drilling and Construction, Addenda issued prior to execution, Amendments issued after execution.

None.

These documents form the entire contract and are as fully a part of the Agreement as if attached to this Agreement or repeated herein. Contractor represents and agrees it has carefully examined and understands this Agreement and the Contract Documents.

2. SCOPE OF WORK. The Contractor shall furnish all work, labor, services, supplies, materials, equipment, tools, transportation, supervision, appliances, and appurtenances required for the prompt and efficient completion of the project described as the Innovation Well and Army Aviation Well Drilling, Construction, Development, and Testing project. The wells will be drilled on TMWA property at the following locations: just north of 6995 Longley Lane, and 20100 Army Aviation Drive, Reno, Nevada. The Work consists of completing all activities to drill, construct, develop, and test a production well at each site (“Project”) as described in the Contract Documents and in accordance with the contract provisions, Plans, and Specifications, together with all work incidental or reasonably inferable which is necessary to produce the results intended by the Contract Documents (collectively, the “Work”). Contractor shall be responsible for the supervision and coordination of the Work, including the construction means, methods, techniques, sequences and procedures utilized, unless the Contract Documents specifically provide otherwise. The Contractor

represents and warrants that it has fully investigated the nature, locality and site of the Work and the conditions and difficulties under which it is to be performed, and that it enters into this Agreement on the basis of its own examination, investigation and evaluation of all such matters and is in no way relying upon any opinions or representations of the Owner, or any of their respective officers, agents, servants, or employees with respect thereto.

3. **TIME OF COMPLETION.** All times stated in the Contract Documents, including interim milestones and those for the delivery and installation of materials and equipment, are of the essence of this Agreement

3.1 **Commencement of Work.** Contractor shall promptly commence and diligently prosecute the Work to be performed under this Agreement on the date fixed in a Notice to Proceed and shall perform the Work diligently, expeditiously and with adequate resources so as to complete the Work on time.

3.2 **Completion of Work.** Contractor shall achieve Substantial Completion by N/A **days from the date of the Notice to Proceed** and shall achieve 100 percent completion by **eighty-four (84) days from the date of the Notice to Proceed**. In addition, the Contractor shall achieve any critical intermediate project milestone dates as identified and defined in Article 7 of the Supplementary Conditions. Contractor shall reschedule or resequence the Work, to the extent possible, to avoid or minimize any delay to the contract time. Contractor agrees it included adequate costs in the Contract Sum to provide sufficient levels of labor and equipment (including overtime if required) to insure that the specified dates are met. The contract time set forth herein assumes **zero (0) weather delay days** will occur during construction of the Project, and the Contract time will not be extended unless weather delay days exceed the days specified above. Should the Contractor fail to complete the Work in the time agreed upon, the Contractor will be subject to liquidated damages as provided herein.

3.3 **Liquidated Damages:** Owner and Contractor recognize time is of the essence and Owner will suffer extensive damages if the Work is not completed within the time specified above, the exact amount of which is difficult to ascertain as of the effective date of this Agreement. Accordingly, if Contractor fails to achieve Substantial Completion of the Work within the time specified above, Owner shall be entitled to retain or recover from Contractor, as liquidated damages for delay (but not as a penalty) the sum of **\$0.00 (Zero Dollars)** per day commencing on the expiration of the time specified above and continuing until the actual date of Substantial Completion is achieved; and if Contractor fails to achieve 100 percent completion of the Work within the time specified above, Owner shall be entitled to retain or recover from Contractor, as liquidated damages for delay (but not as a penalty) the sum of **\$1,000.00 (One Thousand Dollars)** per day commencing on the expiration of the time specified above and continuing until the actual date of 100 percent completion. Owner may deduct liquidated damages from any unpaid amounts then or thereafter due the Contractor under this Agreement. If TMWA terminates the Contractor for default, the resulting damage will consist of liquidated damages until such reasonable time as may be required for final completion of the work together with any increased cost occasioned by TMWA in completing the Work.

3.4 **Construction Schedule.** Contractor shall, not less than ten (10) calendar days after execution of this Agreement by TMWA, prepare and submit a proposed Construction Schedule to TMWA for review and acceptance in accordance with the General Conditions.

4. **CONTRACT SUM.**

4.1 **Construction Contract Price.** Owner shall pay the Contractor, as full and complete compensation for Contractor's timely performance of all the Work in accordance with the Contract Documents and to the satisfaction of Owner, the lump sum amount of: _____ **Dollars** (the "**Contract Sum**"). The amount set forth above includes the aggregate amount of all allowances and unit price items to be furnished or installed.

5. **PAYMENTS.**

5.1 **Progress Payments.** The Owner will pay the Contractor progress payments and the final payment in

accordance with the provisions set forth in the Specifications computed from the actual quantities of work performed and accepted, and the materials furnished, at the unit and lump sum prices shown in the Proposal, as bid in conformance with the Contract Documents defined hereinafter. Owner will retain from such estimated value of the work done the amounts specified in the General Conditions. Owner shall pay to Contractor, at the end of each quarter this Agreement is in effect, interest for the quarter on the amount withheld at a rate to be determined by Owner in accordance with NRS 338.515. Except with respect to any payment withheld pursuant to NRS 338.525, the amount of payments withheld as provided herein shall be retained for a period of 30 days from the date of project Completion and acceptance. Contractor shall pay the subcontractors progress payments and pay interest on amounts retained from said progress payments in accordance with the provisions of NRS 338.510 through NRS 338.535.

5.2 Acceptance and Final Payment. As soon as practical following the completion of all phases of the Work, the Contractor shall make request by letter to Owner for a final inspection and acceptance of the Work, and if, in Owner's opinion, all provisions of the Contract Documents and Agreement have been satisfied, Owner will cause a Notice of Completion to be completed by the Project Representative and sent to the Labor Commissioner. Final payment, constituting the entire unpaid balance of the contract sum, shall be made by Owner to Contractor when the obligations in the Contract Documents have been fully performed by Contractor except for Contractor's responsibility to satisfy requirements, if any, which necessarily survive final payment; and the Notice of Completion has been sent to the Labor Commissioner and no prevailing wage disputes are under investigation by TMWA or pending before the Labor Commissioner. Final payment shall be made by Owner not more than 30 calendar days following the Notice of Completion, as specified in the General Conditions. Final payment is further subject to Owner's prior receipt from Contractor of all as-built drawings, certifications, prevailing wages, maintenance manuals, operating instructions, written guarantees, warranties, and bonds relating to the Work, and assignments of all guarantees and warranties from subcontractors, vendors, suppliers, or manufacturers, all as required by the Contract Documents. Acceptance of final payment by the Contractor shall constitute a full waiver and release by the Contractor of all claims against Owner arising out of or relating to this Agreement.

6. PREVAILING WAGE.

Contractor will pay, and will require all subcontractors to pay, unless otherwise exempt there from, all employees on said work a salary or wage at least equal to the prevailing salary or wage established for such work as set forth in the wage determinations and wage standards applicable to this work, as contained in or referenced by the Contract Document provisions for this Work. Pursuant to NRS 338.060, Contractor shall forfeit to the Owner, as a penalty, not less than \$20 or more than \$50 for each calendar day and portion thereof that each workman employed on the public work: (a) is paid less than the designated rate for work done under the contract by the Contractor or any subcontractor under him (b) is not reported to the public body awarding as required pursuant to NRS 338.070. In the performance of this Agreement, not more than eight (8) hours shall constitute a day's work, and the Contractor shall not require more than (8) hours of labor in a day from any person employed by him hereunder. Contractor shall keep accurate records showing the name, occupation and actual per diem wages and benefits paid to each workman employed by him in connection with this project. The records shall be certified in LCP Tracker and open to inspection by Owner, its officers and agents and at all reasonable hours. Contractor shall inquire, and shall require each subcontractor to inquire, of each worker employed in connection with the public work whether the worker wishes to voluntarily specify his or her gender and ethnicity, and shall record and maintain such responses in accordance with NRS 338.070.

7. INSURANCE.

The Contractor shall purchase and maintain prior to performing any Work on the Project, at its sole expense, from a company or companies authorized to do business in the State of Nevada, insurance policies containing the types of coverages and minimum limits of liability described in the General Conditions protecting from claims which may arise out of or result from the performance or non-performance of services under this Agreement by the Contractor or by anyone directly or indirectly employed by it, or by anyone for whose acts it may be liable, including without limitation subcontractors, independent contractors, and agents. Contractor shall procure and maintain at a

minimum the insurance as required in the General Conditions, and shall require all subcontractors to procure and maintain at a minimum the insurance as required in the General Conditions, including but not limited to industrial insurance as required by the Nevada Industrial Insurance Act and the Nevada Occupational Diseases Act. Contractor or his subcontractor(s) failure to pay premiums will automatically authorize Owner to, at its option, terminate this Agreement or withhold amounts from funds due the Contractor and make insurance premium payments on behalf of the Contractor and/or his subcontractors. Contractor shall provide Owner insurance certificates no later than 10 days after the date of the Notice of Award, and Contractor's failure to timely provide insurance certificates shall not result in any extensions to the contract time.

8. PERFORMANCE AND PAYMENT BONDS.

The Contractor shall, prior to the execution of the Agreement, furnish two bonds on the forms bound herein approved by the Owner, one in the amount of One Hundred Percent (100%) of the Contract Sum, to guarantee the faithful performance of the work, and one in the amount of One Hundred Percent (100%) of the Contract Price to guarantee payment of all claims for labor and materials furnished. This Contractor shall not begin work until such bonds are supplied to and approved by the Owner. Contractor shall provide Owner contract bonds no later than 10 days after the date of the Notice of Award, and Contractor's failure to timely provide bonds shall not result in any extensions to the contract time.

9. NONDISCRIMINATION.

In accordance with NRS 338.125, in connection with the performance of work under this Agreement, the Contractor agrees not to discriminate against any employee or applicant for employment because of race, creed, color, national origin, sex or age. Such agreements shall include, but not be limited to, the following: Employment, upgrading, demotion or transfer, recruitment or recruitment advertising, layoff or termination, rates of pay or other forms of compensation, and selection for training, including apprenticeship. Any violation of such provision by the Contractor shall constitute a material breach of the Agreement. Further, Contractor agrees to insert this nondiscrimination provision in all subcontracts hereunder, except subcontracts for standard commercial supplies or raw materials.

10. PREFERENCES.

10.1 Veteran's Preference. Contractor agrees to give preference as provided in NRS 338.130. If this provision is not complied with, the Agreement shall be void, and any failure or refusal to comply with this provision shall render the Agreement void.

10.2 Bidder Preference. To the extent Contractor has sought and qualified for a bidding preference and this project has a value of over \$250,000 pursuant to Nevada Revised Statutes Chapter 338, Contractor acknowledges and agrees that the following requirements shall be adhered to, documented and maintained for the duration of the Project, collectively, and not on any specific day:

a. At least 50 percent of the workers employed on the Project (including subcontractors) must hold a valid driver's license or identification card issued by the Nevada Department of Motor Vehicles;

b. All vehicles used primarily for the public work will be (a) registered and (where applicable) partially apportioned to Nevada; or (b) registered in Nevada.

c. If applying to receive a preference in bidding pursuant to NRS 338.1727, at least 50 percent of the design professionals who work on the Project (including sub-contractors) hold a valid driver's license or identification card issued by the Nevada Department of Motor Vehicles; and

d. The Contractor and any subcontractor engaged on the public work shall maintain and make available

for inspection within Nevada all payroll records related to the Project.

Contractor recognizes and accepts that failure to comply with any requirements herein shall entitle Owner to a penalty in the amount set by statute. In addition, the Contractor recognizes and accepts that failure to comply with any requirements herein may result in loss of certification for a preference in bidding for 5 years and/or ability to bid on any contracts for public works for one year pursuant to NRS Chapter 338.

11. WARRANTY.

In addition to any other warranties provided by law or in the General conditions, Contractor warrants the Work under this Agreement to be free from all defects for a period of one year from the date of final acceptance by Owner. Any defects found during this period shall be repaired by the Contractor at no cost to Owner in accordance with the requirements of the Contract Documents.

12. INDEMNIFICATION/HOLD HARMLESS.

Owner has established specific indemnification requirements which are fully set forth in the General Conditions, which Contractor has examined, understands and agrees to perform.

13. MISCELLANEOUS.

13.1 Termination. In addition to other provisions set forth in the Contract Documents, Owner has the right to terminate the Agreement without cause at any time upon giving Contractor seven days notice in writing. In the event the Agreement is terminated by Owner in accordance with this provision, Owner agrees to pay Contractor for all work satisfactorily completed and for materials installed prior to the date of termination to the extent otherwise due under this Agreement.

13.2 Governing Law. This Agreement shall be governed by, interpreted under and construed and enforced in accordance with the laws of the State of Nevada, with venue in the County of Washoe. Each party acknowledges and agrees that the laws of the State of Nevada and the selection of venue were freely chosen.

13.3 Compliance with Laws. Pursuant to NRS 338.153, Contractor shall comply, and shall insure each subcontractor and other person who provides labor, equipment, materials, supplies or services for the Project complies, with the requirements of all applicable state and local laws, including without limitation, any applicable licensing requirements and requirements for the payment of sales and use taxes on equipment, materials and supplies provided for the Project.

13.4 Confidentiality. Contractor acknowledges and agrees the Drawings and Technical Specifications reveal critical infrastructure of facilities used for storing, transporting or transmitting water as contemplated by Nevada's Homeland Security Act, and that the disclosure or release of the Drawings and Technical Specifications to any unauthorized person would create a substantial likelihood of compromising, jeopardizing or otherwise threatening the public health, safety or welfare. Contractor shall not, and shall ensure its Subcontractors, employees and agents shall not, knowingly disclose such documents or information or assist, solicit or conspire with another person to disclose such documents or information Contract Documents without the express prior written consent of Owner.

13.5 Attorneys' Fees. If either party hereto fails to perform any of its obligations under this Agreement or if any dispute arises between the parties hereto concerning the meaning or interpretation of any provision of this Agreement, then the defaulting party or the party not prevailing in such dispute, as the case may be, shall pay any and all costs and expenses incurred by the other party in enforcing or establishing its rights hereunder, including, without limitation, court costs and reasonable attorneys' fees and disbursements. Any such attorneys' fees and other expenses incurred by either party in enforcing a judgment in its favor under this Agreement shall be recoverable separately from

and in addition to any other amount included in such judgment, and such attorneys' fees obligation is intended to be severable from the other provisions of this Agreement and to survive and not be merged into any such judgment.

13.6 Modifications. This Agreement cannot be changed orally, and no executory agreement shall be effective to waive, change, modify or discharge it in whole or in part unless such executory agreement is in writing and is signed by the parties against whom enforcement of any waiver, change, modification or discharge is sought

13.7 Entire Agreement. This Agreement, including the exhibits and schedules hereto, contains the entire agreement between the parties hereto pertaining to the subject matter hereof and fully supersedes all prior written or oral agreements and understandings between the parties pertaining to such subject matter.

13.8 Severability. If any provision of this Agreement is held illegal or unenforceable in a judicial proceeding, such provision shall be severed and shall be inoperative, and, provided that the fundamental terms and conditions of this Agreement (including, without limitation, remain legal and enforceable, the remainder of this Agreement shall remain operative and binding on the Parties.

IN WITNESS WHEREOF, Owner and Contractor hereby enter into this agreement as of the date and year first written above.

<p>“Owner”</p> <p>TRUCKEE MEADOWS WATER AUTHORITY, a joint powers authority</p> <p>By: _____ Date: _____</p> <p>General Manager</p>

STATE OF _____)
) ss
County of _____)

_____ states under penalty of perjury that he/she is the Contractor, or authorized agent of the Contractor, by whom the aforesaid described Work is to be performed; that he/she has read the foregoing Contract and understands and agrees to the terms, conditions, and requirements thereof.

CONTRACTOR:

By:
Title:
Firm:
Address:
City/State & Zip:
Telephone:
Fax:
E-mail:

ATTEST:

On this _____ day of _____, in the year 20 __, before me, _____ /Notary Public, personally appeared or personally known to me (or proved to me on the basis of satisfactory evidence) to be the person whose name is subscribed to this instrument, and acknowledged that he (she) executed it.
WITNESS my hand and official seal.

(Signature Of Contractor)

Notary's Signature

DATED this ____ day of _____, 20__.

L.S.

PERFORMANCE BOND

WHEREAS, Contractor has by written agreement dated _____, 20__ entered into a contract with Truckee Meadows Water Authority for PWP Bid #WA-2015-235 and titled "**Innovation Well and Army Aviation Well Drilling, Construction, Development and Testing**" in accordance with drawings and specifications prepared by Truckee Meadows Water Authority and which contract is by reference made a part hereof, and is hereinafter referred to as the Agreement.

NOW THEREFORE, KNOW ALL MEN BY THESE PRESENTS, that the undersigned, as Principal, hereinafter called Contractor, and _____, a corporation duly organized or authorized to do business under the laws of the State of Nevada, as Surety, hereinafter called the Surety, are held and firmly bound unto the Truckee Meadows Water Authority, a joint powers authority created pursuant to NRS Chapter 277, for the Sum of _____ Dollars (\$_____), to be paid to said Truckee Meadows Water Authority for which payment, well and truly to be made, we bind ourselves, our heirs, executors, administrators, successors and assigns, jointly and severally, firmly by these presents. This bond shall be governed by the laws of the State of Nevada.

THE CONDITION OF THIS OBLIGATION IS SUCH that, if Contractor shall fail to promptly and faithfully perform said Agreement, or Contractor shall be, and is declared by Truckee Meadows Water Authority to be in default under the Agreement, Truckee Meadows Water Authority having performed Truckee Meadows Water Authority 's obligations thereunder, the Surety may promptly remedy the default or shall promptly:

- 1) Complete the Agreement in accordance with its terms and conditions; or
- 2) Obtain a bid or bids for completing the Agreement in accordance with its terms and conditions, and upon determination by Truckee Meadows Water Authority and the Surety jointly of the lowest responsive, responsible bidder, arrange for a contract between such bidder and Truckee Meadows Water Authority, and make available as work progresses (even though there should be a default or a succession of defaults under the contract or contracts of completion arranged under this paragraph) sufficient funds to pay the cost of completion less the balance of the contract price, but not exceeding, including other costs and damages for which the Surety may be liable hereunder, the amount set forth in the first paragraph hereof. The term "balance of the contract price", as used in this paragraph, shall mean the total amount payable by Truckee Meadows Water Authority to Contractor under the Agreement and any amendments thereto, less the amount properly paid by Truckee Meadows Water Authority to Contractor. No right of action shall accrue on this bond to or for the use of any person or corporation other than Truckee Meadows Water Authority or successors of Truckee Meadows Water Authority.

If Contractor shall fully, promptly and faithfully perform all Contractor's obligations under the Agreement, then this obligation shall be null and void; otherwise it shall remain in full force and effect. The Surety hereby waives notice of any alteration or extension of time made by Truckee Meadows Water Authority and its obligation is not affected by any such alteration or extension provided the same is within the scope of the contract.

PERFORMANCE BOND

Continued for PWP BID #WA-2015-235 and titled " Innovation Well and Army Aviation Well Drilling, Construction, Development and Testing"

BY:	(signature of Principle)
TITLE:	L.S.
FIRM:	
Address:	
City, State, Zip:	
Phone:	

Printed Principal's Name: _____

Attest by: _____ (signature of Notary)

Subscribed and Sworn before me this _____ day of _____, 20____.

Notary public for the State of _____

**CLAIMS UNDER THIS BOND
MAY BE ADDRESSED TO:**

Agent Information

Name of Surety	Name of Licensed Agent
Address	Address
City	City
State/Zip Code	State/Zip Code
Name	Agent's Name
Title	Agent's Title
Telephone	Agent's Telephone

Surety's Acknowledgment:	Agent's Acknowledgment:
By:	By:

NOTICE:

No substitution or revision to this bond form will be accepted. Sureties must be authorized to do business in and have an agent for service of process in the State of Nevada. Certified copy of Power of Attorney must be attached.

LABOR AND MATERIAL PAYMENT BOND

WHEREAS, Contractor has by written agreement dated _____, 20____ entered into a contract with Truckee Meadows Water Authority for **PWP Bid #WA-2015-235** and titled "**Innovation Well and Army Aviation Well Drilling, Construction, Development and Testing**" in accordance with drawings and specifications prepared by Truckee Meadows Water Authority and which contract is by reference made a part hereof, and is hereinafter referred to as the Agreement.

NOW THEREFORE, KNOW ALL MEN BY THESE PRESENTS, that the undersigned, as Principal, hereinafter called Contractor, and _____, a corporation duly organized or authorized to do business under the laws of the State of Nevada, as Surety, hereinafter called the Surety, are held and firmly bound unto the Truckee Meadows Water Authority, a joint powers authority created pursuant to NRS Chapter 277, for the Sum of _____ Dollars (\$_____), to be paid to said Truckee Meadows Water Authority for which payment, well and truly to be made, we bind ourselves, our heirs, executors, administrators, successors and assigns, jointly and severally, firmly by these presents. This bond shall be governed by the laws of the State of Nevada

THE CONDITION OF THIS OBLIGATION IS SUCH that, if Contractor, its heirs, executors, administrators, successors or assigns shall fail to pay for any materials, provision, supplies, implements or machinery used in, upon, for, or about the performance of the work contracted to be done, or for any work or labor thereon of any kind, together with interest at the rate of twelve percent per annum, or for amounts due under the unemployment compensation law with respect to such work or labor, as required by the provisions of NRS 612, and Surety shall promptly make payment to all claimants as hereinafter defined, for all labor and material used or reasonably required for use in the performance of the Contract not to exceed the sum specified in this Bond, subject, however, to the following conditions:

- 1) A claimant is defined as one having a direct contract with the Contractor or with a Subcontractor of the Principal for labor, material, or both, used or reasonably required for use in the performance of the Contract, labor and material being construed to include that part of water, gas, power, light, heat, oil, gasoline, telephone service, or rental of equipment directly applicable to the Contract.
- 2) The above-named Principal and Surety hereby jointly and severally agree with Truckee Meadows Water Authority that every claimant as herein defined, who has not been paid in full before the expiration of a period of ninety (90) days after the date on which the last of such claimant's work or labor was done or performed, or materials were furnished by such claimant, may sue on this bond for the use of such claimant, prosecute the suit to final judgment for such sum or sums as may be justly due claimant, and have execution thereon. Truckee Meadows Water Authority shall not be liable for the payment of any costs or expenses of any such suit.
- 3) No suit or action shall be commenced hereunder by any claimant:
 - a) Unless claimant, other than one having a direct contract with the Contractor, shall have given written notice to any two of the following: the Contractor, Truckee Meadows Water Authority, or the Surety above named, within ninety (90) days after such claimant did or performed the last of the work or labor, or furnished the last of the materials for which said claim is made, stating with substantial accuracy the amount claimed and the name of the party to whom the materials were furnished, or for whom the work or labor was done or performed. Such notice shall be personally served or served by mailing the same by registered mail or certified mail, postage prepaid, in an envelope addressed to the Principal at any place the Principal maintains an office or conducts its business.
 - b) After the expiration of one (1) year following the date on which the last of the labor was performed or material was supplied by the party bringing suit.
 - c) Other than in a court of competent jurisdiction for the county or district in which the construction contract was to be performed.

LABOR AND MATERIAL PAYMENT BOND

Continued for **PWP Bid #WA-2015-235** and titled "Innovation Well and Army Aviation Well Drilling, Construction, Development and Testing"

4) The amount of this bond shall be reduced by and to the extent of any payment or payments made in good faith hereunder.

BY:	(signature of Principle)
TITLE:	L.S.
FIRM:	
Address:	
City, State, Zip:	
Phone:	

Printed Principal's Name: _____

Attest by: _____ (signature of Notary)

Subscribed and Sworn before me this _____ day of _____, 20____.

Notary public for the State of _____

**CLAIMS UNDER THIS BOND
MAY BE ADDRESSED TO:**

Licensed Agent Information

Name of Surety	Name of Licensed Agent
Address	Address
City	City
State/Zip Code	State/Zip Code
Name	Agent's Name
Title	Agent's Title
Telephone	Agent's Telephone

Surety's Acknowledgment: _____ **Licensed Agent's Acknowledgment:** _____

By: _____ **By:** _____

NOTICE:

No substitution or revision to this bond form will be accepted. Sureties must be authorized to do business in and have an agent for service of process in the State of Nevada. Certified copy of Power of Attorney must be attached.

Section 00700

GENERAL CONDITIONS

Article 1 Definitions and Terminology3
1.01 Defined Terms..... 3
1.02 Terminology..... 7
Article 2 General and Preliminary Items7
2.01 Notices 7
2.02 NRS Requirements..... 7
2.03 Holidays 8
2.04 ADA Requirements..... 8
2.05 Notice to Proceed 8
2.06 Preconstruction Meeting 8
2.07 Schedules 9
2.08 Initial Submittal of Labor and Equipment Rates..... 9
2.09 Work Hours..... 9
2.10 Contractor and Subcontractor Responsibility, Qualifications and License..... 10
2.11 Geotechnical Report..... 10
Article 3 Contract Documents 10
3.01 Examination of Contract Documents 10
3.02 Intent and Correlation 10
3.03 Standards..... 11
3.04 Work Change Directive 11
3.05 Changes to the Contract 12
3.06 Ownership and Return of Contract Documents 13
Article 4 Physical Conditions, Lands, Reference Points 13
4.01 Availability of Lands 13
4.02 Site Investigation and Conditions Affecting the Work 15
4.03 Differing Conditions 16
4.04 Reference Points 16
4.05 Hazardous Environmental Conditions 17
4.06 Rock Excavation 18
Article 5 Bonds and Insurance20
5.01 Performance and Payment Bonds 20
5.02 Contractor’s Insurance 20
5.03 Property Insurance 22
Article 6 Contractor’s Responsibilities.....22
6.01 Laws and Regulations 22
6.02 Supervision of the Work and Subcontractors..... 22
6.03 Contractor Personnel..... 23
6.04 Location of Underground Facilities 23
6.05 Materials 24
6.06 Permits 25
6.07 Submittals for Items That Will Be Incorporated Into the Work 25
6.08 Submittals for Other Items 27
6.09 “Or Equal” Items..... 27
6.10 Substitutions..... 28
6.11 Worker Safety and Accident Prevention..... 28

6.12	Use of Site.....	30
6.13	Protection of Existing Vegetation and Improvements	30
6.14	Construction Site Stormwater Control.....	30
6.15	Dust Control.....	32
6.16	Quality Control	33
6.17	Record Drawings.....	33
6.18	Warranty	34
6.19	Right to Audit	34
Article 7	Payment and Retention	35
7.01	Payment for Mobilization	35
7.02	Progress Payments	35
7.03	Extra Work – Request for Approval	36
7.04	Extra Work – Payment for Time and Material Work.....	36
7.05	Unit Cost Adjusting Bid Items.....	42
7.06	Retention and Final Payment	42
Article 8	Time Extensions and Delays	43
8.01	Time Extensions.....	43
8.02	Delays	44
8.03	Excusable Delays	44
Article 9	Suspension and Termination of Work	45
9.01	Suspension of Work.....	45
9.02	Termination for Convenience	45
9.03	Termination for Cause	45
Article 10	Other Provisions	46
10.01	Related Work at Site	46
10.02	Inspection and Testing by TMWA.....	46
10.03	Replacement of Defective Work.....	47
10.04	Use and Possession Prior to Completion	47
10.05	Dispute Resolution.....	47
Article 11	Miscellaneous Legal Provisions	49
11.01	Jurisdiction.....	49
11.02	Assignment	49
11.03	No Waiver.....	49
11.04	Severability and Integration	49
11.05	Indemnity	50

Article 1 Definitions and Terminology

1.01 Defined Terms.

Wherever used in these General Conditions or in the other Contract Documents the following terms have the meanings indicated which are applicable to both the singular and plural thereof:

- A. Addenda – Written or graphic instruments issued prior to the opening of Bids which clarify, correct, or change the bidding documents or the Contract Documents.
- B. Agreement – The written Agreement for Construction between TMWA and Contractor covering the Work to be performed; other Contract Documents are attached to, or referenced in, the Agreement and made a part thereof as provided therein.
- C. Application for Payment – The form accepted by Project Representative, which is to be used by Contractor in requesting progress or final payments and which is to include such supporting documentation as required by the Contract Documents.
- D. Asbestos – Any material that contains more than one percent asbestos and is friable or is releasing asbestos fibers into the air above current action levels established by the United States Occupational Safety and Health Administration.
- E. Bid – The offer or proposal of the bidder submitted on the prescribed form setting forth the prices for the Work to be performed.
- F. Bidding Documents – Invitation to Bid, Instructions to Bidders, the Bid Form including any required attachments, Bid Bond, the proposed Contract Documents, Reference Documents, and any Addenda issued prior to receipt of Bids.
- G. Bidding Requirements – The advertisement or Invitation to Bid, Instructions to bidders, and the Bid form.
- H. Bidder – One who submits a bid directly to TMWA, as distinct from a sub-bidder, who submits a bid to a Bidder.
- I. BMP or BMP's – Best management practices to reduce or prevent erosion and to control the sediment and wastes generated from construction activities and transported in stormwater runoff. BMP's on TMWA Projects shall be as defined in the BMP Handbook.
- J. BMP Field Guide – The Nevada Contractors Field Guide for Construction Site Best Management Practices. The field guide is available at www.TMstormwater.com.
- K. BMP Handbook – The Truckee Meadows Construction Site Best Management Practices Handbook, latest revision. The handbook is available at www.TMstormwater.com.
- L. Bonds – Bid, performance and payment bonds, and other instruments of security.
- M. Change Order – A document recommended by Project Representative, which is authorized prior to work begins and signed by Contractor and TMWA and authorizes an addition, deletion, or revision in the Work, or an adjustment in the Contract Sum or the Contract Time, issued on or after the Effective Date of the Agreement.
- N. Contract Bonds – The performance and payment bonds. Also referred to as Contract Security.
- O. Contract Documents – consist solely of the Agreement, Addenda or Amendments to the Agreement (if any), Contractor's Bid (including documentation accompanying the Bid and any post-Bid documentation submitted prior to the Notice of Award, but excluding any added or amended terms, conditions, or provisions limiting liability or the insurance required herein) when

attached as an exhibit to the Agreement, the Notice to Proceed, the Bonds, the General Conditions, the Supplementary Conditions, the Technical Specifications, and the Drawings as the same are more specifically identified in the Agreement, together with all written amendments, modifications, and supplements issued on or after the Effective Date of the Agreement.

- P. Contract Sum – The amount payable by TMWA to Contractor under the Contract Documents as stated in the Agreement (subject to modification for Unit Price Work).
- Q. Contract Time – The number of days or the date stated in the Agreement for the completion of the Work.
- R. Contractor – The person, firm, or corporation with whom TMWA has entered into the Agreement, licensed by the Nevada (and California, where applicable) State Contractors Board.
- S. Day – A calendar day unless specifically noted as a working day.
- T. Defective – An adjective which when modifying the word Work refers to Work that is unsatisfactory, faulty, or deficient, or does not conform to the Contract Documents, or does not meet the requirements of any inspection, reference standard, test, or approval referred to in the Contract Documents, or has been damaged prior to Project Representative's approval of final payment (unless responsibility for the protection thereof has been assumed by TMWA at Substantial Completion).
- U. Drawings – The drawings which show the character and scope of the Work to be performed and which have been prepared or approved by Engineer and are referred to in the Contract Documents.
- V. Effective Date of the Agreement – The date indicated in the Agreement on which it becomes effective, but if no such date is indicated it means the date on which the Agreement is signed and delivered by the last of the two parties to sign and deliver.
- W. Engineer – TMWA's technical representative.
- X. Hazardous Waste – The term Hazardous Waste shall have the meaning provided in Section 1004 of the Solid Waste Disposal Act (42 USC Section 6903) as amended from time to time.
- Y. Laws and Regulations; Laws or Regulations – Laws, rules, regulations, ordinances, codes, and/or orders.
- Z. Milestone – A principal event specified in the Contract Documents relating to an intermediate completion date or time prior to Substantial Completion of all the Work.
- AA. Notice of Award – The written notice by TMWA to the apparent successful bidder stating that upon compliance by the apparent successful bidder with the conditions precedent enumerated therein, within the time specified, TMWA will sign and deliver the Agreement.
- BB. Notice to Proceed – A written notice given by TMWA to Contractor fixing the date on which the Contract Time will commence to run and on which Contractor shall start to perform Contractor's obligations under the Contract Documents.
- CC. Owner or Company – Truckee Meadows Water Authority (TMWA).
- DD. Partial Utilization – Use by TMWA of a substantially completed part of the work for the purpose for which it is intended (or a related purpose) prior to Substantial Completion of all the work.
- EE. Petroleum – Petroleum, including crude oil or any fraction thereof which is liquid at standard conditions of temperature and pressure (60 degrees Fahrenheit and 14.7 pounds per square inch

absolute), such as oil, petroleum, fuel oil, oil sludge, oil refuse, gasoline, kerosene, and oil mixed with other non-Hazardous Wastes and crude oils.

- FF. Project – The total construction of which the Work to be provided under the Contract Documents may be the whole, or a part as indicated elsewhere in the Contract Documents.
- GG. Project Manual – Volume or volumes containing the Bidding Requirements, Contract Forms, Conditions of the Contract, and Specifications.
- HH. Project Representative – The authorized representative of TMWA assigned to the Project or any part thereof and is responsible for administration of the construction contract. May also be referred to as Construction Management Administrator, Project Administrator, or Project Coordinator.
- The Project Representative is the sole point of contact for the Contractor on matters relating to the Work. References to “Engineer” or “Architect” in the Specifications shall be understood to mean the Project Representative.
- II. Purchasing/Contracts Administrator – TMWA’s designated representative for all matters pertaining to bidding and contract award for the Project.
- JJ. Radioactive Material – Source, special nuclear, or byproduct material as defined by the Atomic Energy Act of 1954 (42 USC Section 2011 et seq.) as amended from time to time.
- KK. Reference Documents – Documents that provide supplemental information about TMWA furnished equipment, easements, rights-of-way, and other similar items, made available for use by the Bidder in Bid preparation. Reference Documents are not part of the Contract Documents and are provided without representation or warranty as to accuracy or completeness.
- LL. Samples – Physical examples of materials, equipment, or workmanship that are representative of some portion of the work and which establish the standards by which such portion of the work will be judged.
- MM. Shop Drawings – All drawings, diagrams, illustrations, schedules, and other data or information which are specifically prepared or assembled by or for Contractor to illustrate some portion of the Work and all illustrations, brochures, standard schedules, performance charts, instructions, diagrams, and other information prepared by a Supplier and submitted by Contractor to illustrate material or equipment for some portion of the Work.
- NN. Special Provisions – A section in Division 1 of the Technical Specifications that specifies Project specific requirements such as TMWA furnished equipment, construction utilities, description of work, and items of a similar nature. May also be titled “Special Conditions.” May not be used for all Projects.
- OO. Subcontractor – An individual, firm, or corporation having a direct contract with Contractor or with any other Subcontractor for the performance of a part of the Work.
- PP. Substantial Completion – The Work (or a specified part thereof) has progressed to the point where, in the opinion of Project Representative as evidenced by Project Representative definitive certificate of Substantial Completion, is sufficiently complete, in accordance with the Contract Documents, so that the Work (or specified part) can be utilized for the purposes for which it is intended; or if there be no such certificate issued, when final payment is due. The terms "substantially complete" and "substantially completed" as applied to any Work refer to Substantial Completion thereof.
- QQ. Successful Bidder – The Bidder to whom TMWA awards a contract. The Successful Bidder becomes the Contractor upon execution of the Agreement by TMWA.

- RR. Superintendent – Contractor's Representative on site who has the authority to act on behalf of the Contractor.
- SS. Supplementary Conditions – The part of the Contract Documents which amends or supplements these General Conditions.
- TT. Supplier – A manufacturer, fabricator, supplier, distributor, material man, or vendor having a direct contract with Contractor or with any subcontractor to furnish materials or equipment to be incorporated in the work by Contractor or any subcontractor.
- UU. Technical Specifications – Those portions of the Contract Documents consisting of written technical descriptions of materials, equipment, construction systems, standards, and workmanship as applied to the Work and certain administrative details applicable thereto. May also be referred to as Specifications. Reference Documents are not part of the Technical Specifications.
- VV. TMWA – Truckee Meadows Water Authority.
- WW. Underground Facilities – All pipelines, conduits, ducts, cables, wires, manholes, vaults, tanks, tunnels or other such facilities or attachments, and any encasements containing such facilities which have been installed underground to furnish any of the following services or materials: electricity, gases, steam, liquid petroleum products, telephone or other communications, cable television, sewage and drainage removal, traffic or other control systems, or water.
- XX. Unit Price Work – Work to be paid for on the basis of unit prices.
- YY. Weather Day – A weather day is defined as a day on which, in the judgment of the Project Representative, the Contractor is prevented from proceeding with at least 75 percent of the normal labor and equipment force engaged in productive contract work for at least 60 percent of a normal eight hour work day due to inclement weather or conditions resulting therefrom.
- In the event that the Project Representative and Contractor agree that the labor force should be dismissed due to adverse weather conditions, and weather conditions then improve, the Contractor will not be allowed a weather day if the labor force is subsequently mobilized and 60 percent or more of a normal eight hour work day is then completed
- ZZ. Work – The entire completed construction or the various separately identifiable parts thereof required to be furnished under the Contract Documents, consisting of all work, labor, services, supplies, materials, equipment, tools, transportation, supervision, appliances, and appurtenances required for the prompt and efficient completion of the Project as described in the Contract Documents and in accordance with the contract provisions, Plans, and Specifications, together with all work incidental or reasonably inferable which is necessary to produce the results intended by the Contract Documents.
- AAA. Work Change Directive – A written directive to Contractor, issued on or after the Effective Date of the Agreement and signed by TMWA, ordering an addition, deletion, or revision in the Work, or responding to differing or unforeseen physical conditions under which the Work is to be performed or to emergencies. A Work Change Directive may not change the Contract Sum or the Contract Time, but is evidence that the parties expect that the change directed or documented by a Work Change Directive will be incorporated in a subsequently issued Change Order following negotiations by the parties as to its effect, if any, on the Contract Sum or Contract Time.
- BBB. Written Amendment – A written amendment of the Contract Documents, signed by TMWA and Contractor on or after the Effective Date of the Agreement and normally dealing with the non-engineering or non-technical rather than strictly Work-related aspects of the Contract Documents.

1.02 Terminology

- A. “Demolish” or “Demo” means the dismantling, destroying, wrecking, or removal of buildings, structures, equipment, piping, or any part thereof and transfer of ownership of items identified for demolition to the Contractor for legal offsite disposal.
- B. “Furnish” means to supply and deliver service, materials, or equipment to the site or other specified location ready for use or installation and in usable or operable condition.
- C. “Install” means to put services, materials, or equipment into use or place in final position complete and ready for intended use.
- D. “Must” means the specified action is mandatory. Synonymous with shall.
- E. “Provide” means to furnish and install services, materials, or equipment complete and ready for intended use.
- F. “Shall” means the specified action is mandatory. Synonymous with must.
- G. “Will” means an intention to complete the specified action in the future, often after certain conditions are fulfilled.

Article 2 General and Preliminary Items

2.01 Notices

- A. Whenever any provision of the Contract Documents requires the giving of written notice, it will be deemed to have been validly given if delivered in person to the individual or to a member of the firm or to an officer of the corporation for whom it is intended, or if delivered at or sent by registered or certified mail, postage prepaid, to the last business address known to the giver of the notice.

2.02 NRS Requirements

- A. Chapters 338 and 339 of the Nevada Revised Statutes (NRS) are hereby incorporated by reference.
- B. These Contract Documents shall be governed by NRS 338 and NRS 339; provided, nothing in the foregoing shall preclude the parties from agreeing to implementing terms or conditions that are more stringent or complementary.
- C. The Contractor’s attention is especially directed to the following sections of NRS Chapter 338:
 - 1. 338.020 – Prevailing Wage Rates (applicable to public works construction contracts exceeding \$100,000).
 - 2. 338.070 – Maintaining Wage and benefit records for Contractors and Subcontractors employees.
 - 3. 338.130 – Preferential employment in public works construction.
 - 4. 338.1377 – Contractor qualifications required for submitting a Bid.
 - 5. 338.141 – Identification of Subcontractors.
 - 6. 338.147 – Preferential bidding status.
 - 7. 338.150 – Arbitration permitted for dispute resolution.
 - 8. 338.490 – Limitations on releases or waiver of rights for receiving payments.
 - 9. 338.515 – Time for making payment; amounts; retention; interest paid.
 - 10. 338.525 – Withholding payment for corrective work.
 - 11. 338.550 to .610 – Payments by Contractor to Subcontractors and Suppliers; and by Subcontractors to Subcontractors and Suppliers.

2.03 Holidays

A. The days listed below are holidays observed by TMWA. Work sites will be closed on these days and access will not be permitted unless the Contractor obtains prior approval from the Project Representative:

- | | |
|---------------------------|------------------------------|
| 1. New Year's Day | January 1 st . |
| 2. Martin Luther King Day | Third Monday in January. |
| 3. President's Day | Third Monday in February. |
| 4. Memorial Day | Last Monday in May. |
| 5. Independence Day | July 4 th . |
| 6. Labor Day | First Monday in September. |
| 7. Nevada Day | Last Friday in October. |
| 8. Veterans Day | November 11 th . |
| 9. Thanksgiving Day | Fourth Thursday in November. |
| 10. Family Day | Friday after Thanksgiving. |
| 11. Christmas Day | December 25 th . |

B. Holidays falling on Saturday will be observed on the preceding Friday and those falling on Sunday will be observed on the following Monday.

2.04 ADA Requirements

- A. All work performed under the Contract Documents shall comply with the Americans With Disabilities Act standards adopted by TMWA.
- B. Facilities completed prior to January 26, 1992 shall comply with the Uniform Federal Accessibility Standards.
- C. Facilities completed after January 26, 1992 shall comply with the Americans With Disabilities Act Accessibility Guidelines.
- D. If the Contractor believes that any portion of the Work does not meet the appropriate accessibility standards, the Project Representative shall be immediately notified.

2.05 Notice to Proceed

- A. After the Agreement is executed by TMWA, and subject to satisfaction of all conditions necessary thereto, TMWA will issue a Notice to Proceed to Contractor.
- B. Contractor shall not move onto, store materials, or perform any work at the site prior to the Notice to Proceed.
- C. Any mobilization of labor, material or equipment by Contractor prior to TMWA issuing the Notice to Proceed is done at the sole risk and expense of the Contractor.

2.06 Preconstruction Meeting

- A. Before Contractor starts the Work at the site, a preconstruction meeting attended by Contractor, Contractor's Superintendent, Engineer, Project Representative, and others as appropriate will be held to discuss the Contractor's schedule, procedures for handling Shop Drawings and other submittals, for processing Applications for Payment, and to establish a working understanding among the parties as to the Work.

2.07 Schedules

- A. Within ten days after the Agreement is executed by TMWA (unless otherwise specified), Contractor shall submit two copies of the following to Project Representative for approval:
 - 1. An estimated construction schedule indicating the starting and completion dates of the various stages of the Work including estimated manpower and equipment requirements.
 - 2. A preliminary schedule of submittals.
 - 3. A preliminary schedule of values for all of the Work which includes quantities and prices of items aggregating the Contract Sum and subdivides the Work into component parts in sufficient detail to serve as the basis for progress payments during construction.
 - 4. Refer to the Special Provisions or Technical Specifications for additional requirements as to the form and content of the construction schedule, submittal schedule, and schedule of values. If no additional requirements are specified, use Contractor's standard format for all schedules.
- B. At least ten days before submission of the first Application for Payment all schedules shall be finalized.
 - 1. The finalized progress schedule shall be acceptable to TMWA as providing an orderly progression of the Work to completion within the Contract Time, but such acceptance will neither impose on TMWA responsibility for the progress or scheduling of the Work nor relieve Contractor from full responsibility therefor.
 - 2. The finalized schedule of submittals shall be acceptable to TMWA as providing a workable arrangement for processing the submissions.
 - 3. The finalized schedule of values shall be acceptable to TMWA as to form and substance.

2.08 Initial Submittal of Labor and Equipment Rates

- A. Before starting any work, the Contractor shall submit labor and equipment rates to the Project Representative for approval. TMWA shall have no obligation to issue the Notice to Proceed until such information is provided.
- B. The submittal shall include:
 - 1. The classification, prevailing hourly wage rate (including fringe benefits), and actual hourly pay rate for each worker that will be employed on the Project. For employees that may work in different classifications, the submittal shall specify the prevailing rate and actual pay rate for each classification.
 - 2. The number, type and cost (specifying equipment rates) of each piece of equipment that the Contractor anticipates using to construct the Work.

2.09 Work Hours

- A. Before starting any work, the Contractor and Project Representative shall agree on the hours that the Contractor will work.
 - 1. The agreed to hours shall be in the range of 7 a.m. to 5:30 p.m. Monday through Friday, holidays excluded (except as modified by local ordinance, permit conditions, Addenda, or the Supplementary Conditions). Work outside these hours, including regular overtime work, shall be subject to the approval of the Project Representative.
 - 2. The agreed to work hours shall not be changed during the life of the Contract Documents except with the approval of the Project Representative.

- B. The Contractor, Subcontractors, and Suppliers shall work common hours. For example, if a normal work schedule of four 10 hour days is agreed to, then all Subcontractors shall work that schedule and material deliveries and other Supplier activities shall also be limited to those hours.

2.10 Contractor and Subcontractor Responsibility, Qualifications, and License

- A. The Contractor and Subcontractors shall hold current licenses from the Nevada State Contractors Board. Licenses shall be of the proper classifications and sub-classifications required to perform the Work.
- B. Contractor represents and warrants that it has appropriate work experience to be qualified to construct the Work and has successfully constructed at least three similar projects (as defined in the Invitation to Bid) of equal or greater size, scope, type, cost, and complexity within the previous seven years.

2.11 Geotechnical Report

- A. Any geotechnical reports made available are for information purposes only, without representation or warranty of any kind with respect to its accuracy or completeness, and are not intended to and shall not be relied upon as a substitute for, or a supplement to, the independent investigation by the Bidder of site conditions. Geotechnical reports made available by TMWA are not part of the Contract Documents.
- B. Use of the information contained in any geotechnical report does not relieve the Contractor from complying with the provisions of Article 4.02 “Site Investigations and Conditions Affecting the Work” of the General Conditions. Bidders and the Contractor are advised to make independent investigations and studies as they deem necessary to be satisfied as to the conditions that will be encountered in performing the Work.
- C. Any conclusions stated in the geotechnical report relative to the character or use of materials that may be found on the site are the opinion of the geotechnical engineer who prepared the report. TMWA does not guarantee that such conclusions are correct and assumes no responsibility for conclusions or interpretations made by Bidders or the Contractor based on information or data contained in the geotechnical report, including conclusions and interpretations that affect the cost of the Work.
- D. No conclusions or interpretations based on the information contained in the geotechnical report will relieve the Contractor from fulfilling the terms of the Contract Documents.

Article 3 Contract Documents

3.01 Examination of Contract Documents

- A. Before undertaking each part of the Work, Contractor shall carefully study and compare the Contract Documents and check and verify pertinent figures shown thereon and all applicable field measurements.
- B. Contractor shall promptly report in writing to Project Representative any conflict, error, or discrepancy which Contractor may discover and shall obtain a written interpretation or clarification from Project Representative before proceeding with any Work affected thereby. Contractor shall be liable to TMWA for costs, expenses, and liabilities arising from its failure to report any conflict, error, or discrepancy in the Contract Documents that Contractor had actual knowledge of or of which Contractor should reasonably have known.

3.02 Intent and Correlation

- A. The Contract Documents are complimentary and what is required by any one shall be binding as if required by all. If, during the performance of the Work, Contractor finds a conflict, error, or discrepancy in the Contract Documents, Contractor shall so report to Project Representative in writing at once and before proceeding with the work affected thereby, shall obtain a written interpretation or clarification from Project Representative.
- B. Any work, materials, or equipment that may reasonably be inferred from the Contract Documents, as being required to produce the intended result shall be supplied whether or not specifically called for, and shall be deemed included in Contractor's bid and the Contract Sum.
- C. In the event that the terms, provisions, conditions, or requirements of one Contract Document conflict with that contained in another Contract Document, then such conflict shall be resolved in accordance with the following order of precedence:
 - 1. Written Amendment to the Agreement.
 - 2. Change Order.
 - 3. Addenda.
 - 4. Technical Specifications.
 - 5. Supplementary Conditions.
 - 6. Drawings.
 - 7. TMWA Standards of Construction
 - 8. General Conditions.
 - 9. Agreement.
- D. Technical Specifications shall take precedence over notes on drawings, and drawing details shall take precedence over large scale drawings.

3.03 Standards

- A. Reference to standard specifications, manuals, or codes of any technical society, organization, or association, or to the laws or regulations of any governmental authority, whether such reference be specific or by implication, shall mean the latest standard specification, manual, code, or Laws or Regulations in effect at the time of opening of Bids, except as otherwise specified.
- B. In the event of conflict between any referenced standard and the Technical Specifications, the Technical Specifications shall govern.
- C. The materials and methods of construction herein specified shall be furnished in accordance with:
 - 1. TMWA's Construction Standards.
 - 2. Parts 2 and 3 of the Standard Specifications for Public Works Construction ("Orange Book") to the extent that they are referenced in the Contract Documents. Part 1 of the Orange Book does not apply to TMWA contracts or work. Sections in Parts 2 and 3 of the Orange Book that are not referenced in the Contract Documents do not apply.
 - 3. The standards of the American Water Works Association (AWWA), American Institute of Steel Construction (AISC), American Concrete Institute (ACI), American Society for Testing and Materials (ASTM), and American Welding Society (AWS).
- D. No provision of any referenced standard specification, manual, or code (whether or not specifically incorporated by reference in the Contract Documents) shall be effective to change the duties and responsibilities of TMWA, Contractor, Engineer, or Project Representative, or any of their consultants, agents, or employees, from those set forth in the Contract Documents, nor shall it be effective to assign to any of TMWA's consultants, agents, or employees any duty or authority to supervise or direct the furnishing or performance of the Work.

3.04 Work Change Directive

- A. The Project Representative may at any time, by written Work Change Directive, and without notice to the sureties, if any, make changes within the general scope of the Contract Documents in any one or more of the following:
 - 1. The Specifications (including drawings and designs).
 - 2. In the method or manner of performance of the work.
 - 3. In TMWA furnished facilities, equipment, materials, services, or site.
 - 4. Directing acceleration in the performance of the work.
- B. If any such change causes an increase or decrease in the cost of, or the time required for, performance of any part of the work under the Contract Documents, TMWA will modify the Contract Documents by Change Order as specified in Article 3.05 “Changes to the Contract” of the General Conditions.
- C. The Contractor shall assert its right to an adjustment under this clause within 30 days from the date of issuance of the Work Change Directive. However, if TMWA decides that the facts justify it, the 30-day period may be extended, provided it occurs before final payment under the Contract Documents.
- D. Failure to agree to any adjustment shall be resolved under the provisions of Article 10.05, “Dispute Resolution.” However, nothing in this clause shall excuse the Contractor from proceeding with the Contract Documents as changed.

3.05 Changes to the Contract

- A. TMWA reserves the right to make changes to the Contract Documents, including the right to increase or decrease the quantity of any item or portion of the Work or to delete any item or portion of the Work, as may be deemed necessary or advisable by the Project Representative and to require such extra work as may be determined by the Project Representative to be essential for the proper completion or construction of the Project.
- B. Changes to the Contract Documents will be set forth in a Change Order that specifies the changes made to the Contract Documents, any additional work to be done as a result of the change, any adjustment of Contract Time associated with the change, and the basis of compensation for the change. The Contractor shall proceed with the work specified in the Change Order after execution by both the Contractor and TMWA or upon receipt of a Work Change Directive instructing the Contractor to proceed with the change prior to execution of the Change Order.
- C. Minor changes to the Contract Documents that do not require adjustment of the Contract Time or change of compensation to the Contractor may be authorized by Engineer’s approval of a Shop Drawing or sample or by Project Representative’s written interpretation or clarification as requested by Contractor.
- D. If any item of work listed in the Bid Schedule is eliminated in its entirety, payment will be made to the Contractor by Change Order for actual costs incurred in connection with the eliminated item if incurred prior to the date of notification in writing by the Project Representative of the elimination. The following rules apply for determination of actual costs incurred.
 - 1. The Contractor will not be compensated for loss of anticipated profit on eliminated items.
 - 2. No markups will be allowed on material or Subcontractor costs.
 - 3. All costs to the Contractor associated with materials ordered prior to the date of notice of elimination will be paid for by TMWA.
 - i. If the orders for the materials cannot be cancelled and the materials cannot be returned to the Supplier, the materials shall become the property of TMWA.

- ii. If the orders for the materials cannot be cancelled but the materials can be returned to the Supplier, the materials shall be returned to the Supplier if so directed by the Project Representative and all restocking and shipping charges will be reimbursed by Change Order. If the Project Representative does not direct the Contractor to return the materials to the Supplier, the materials shall become the property of TMWA.
 - 4. The Contractor shall furnish copies of invoices or other records to the Project Representative to document the costs associated with eliminated items.
- E. For unit price items, if the total pay quantity of an item varies from the quantity listed in the Bid Schedule, the unit price may be adjusted as described below. All adjustments in unit prices will be made by Change Order.
 - 1. If the total pay quantity of a unit price item varies from the quantity listed in the Bid Schedule by 25 percent or less, no adjustment in unit price will be made and payment will be made at the unit bid price.
 - 2. Payment for quantities within ± 25 percent of the quantity listed in the Bid Schedule will be considered to include full recovery by the Contractor of fixed costs associated with that bid item.
 - 3. If the total pay quantity of a unit price item exceeds the quantity listed in the Bid Schedule by more than 25 percent either party to the Agreement may request a unit price adjustment.
 - 4. If the total pay quantity of a unit price item is less than 75 percent of the quantity listed in the Bid Schedule, an adjustment in unit price will be made if requested in writing by the Contractor. The total payment for the item will not exceed that which would be made for 75 percent of the quantity listed in the Bid Schedule at the unit bid price.
 - 5. The method used to make unit price adjustments shall be mutually agreed to by the Contractor and the Project Representative.
- F. For lump sum items, changes in scope and compensation will be made by a Change Order that specifies the increase or decrease in item price.
- G. The labor and equipment rates described in Article 7.04 “Extra Work – Payment for Time and Material Work” of the General Conditions may also be used as the basis for pricing lump sum Change Orders and for unit price adjustments if agreed to by the Contractor and Project Representative. The labor and equipment rates apply to both additive and deductive change orders and unit price adjustments.

3.06 Ownership and Return of Contract Documents

- A. Neither Contractor nor any Subcontractor or Supplier or other person or organization performing or furnishing any of the work under a direct or indirect contract with TMWA shall have or acquire any title to or ownership rights in any of the Drawings, Specifications, or other documents (or copies of any thereof) prepared by TMWA.
- B. All Contract Documents shall be returned to the Project Representative at the completion of the Project. It is the Contractor’s responsibility to collect all sets of Contract Documents from Subcontractors and Suppliers for return to TMWA.

Article 4 Physical Conditions, Lands, Reference Points

4.01 Availability of Lands

- A. TMWA will furnish, as indicated in the Contract Documents, the lands upon which the work is to be performed or rights-of-way, easements or other rights for access thereto, and such other lands which are designated for the use of Contractor.

- B. Easements for permanent structures or permanent changes in existing facilities will be obtained and paid for by TMWA, unless otherwise specified in the Contract Documents.
- C. If the Contractor desires to locate additional staging areas, material storage yards, material processing plants, stockpile areas, equipment parking areas, maintenance areas, employee parking areas, temporary access roads, or similar facilities on lands not designated for the use of the Contractor, the Contractor shall make all arrangements and pay all costs involved for use of the property. Arrangements shall include, but are not limited to, entering into agreements with property owners (including public agencies) and obtaining the necessary permits (including grading and dust control permits), licenses, and environmental clearances.

Agreements with property owners shall, as minimum requirements, include a description of the property and use, the time limits of the agreement, a hold-harmless clause releasing TMWA from any risk or responsibility associated with use of the property, and a requirement to return the property to its original condition or better at completion of use.

Before using each such property, the Contractor shall:

1. Submit a copy of the agreement executed by the Contractor and the property owner to the Project Representative for approval with respect to the minimum requirements listed above.
2. Submit copies of all permits, licenses, and clearances obtained by the Contractor for use of the property. It is the Contractor's responsibility to determine permitting requirements for the proposed use and obtain the permits in a timely manner.
3. For properties 1 acre or larger in size or when required by the Technical Specifications, Supplementary Conditions, or permit conditions, the Contractor shall submit a Notice of Intent to NDEP and prepare a SWPPP for uses that involve storage or stockpiling of materials, equipment parking or maintenance, or any land disturbance. BMP's shall be installed and maintained until final cleanup has been completed regardless of whether an NOI is submitted.
4. Document the condition of the property, adjacent property, drainage facilities, and all streets that will be used by the Contractor to access the property. Documentation shall be as required by the Project Representative and may include video and still photographs submitted on DVD's.

The Contractor shall comply with the conditions of all permits issued for the use, with all terms of the agreements with property owners, and shall return each property used to its original or better condition at completion of the Work. Any damage to adjacent properties, drainage facilities, or streets shall be repaired at Contractor's expense to the satisfaction of the Project Representative.

Temporary access roads shall be constructed in a manner to avoid obstructing drainage, causing damage to other adjacent properties, or endangering the public. This may require construction of retaining structures, excavation supports, guardrails, concrete barrier railing, fences, gates, lined ditches and channels, drainage inlets, culverts, riprap, detention basins, signs, and other temporary facilities all of which shall be provided at Contractor's expense as required by agreements, permits, site conditions, or the Project Representative.

All temporary facilities shall be removed at completion of the Work or when they are no longer needed, whichever occurs first. All properties and areas where access roads were constructed shall be restored to their original lines and grades. If restoration requires placing fill, it shall be structural fill constructed per the requirements of Sections 200.01.09 "Structural Fill" and 304 "Unclassified Fill" of the Orange Book revision 5, dated 2/14/2007. Testing, including compaction testing, of structural fill shall be at the Contractor's expense. Erosion control measures shall be installed per the BMP Handbook and Article 6.14 "Construction Site

Stormwater Control” of the General Conditions. Additional erosion control procedures may be specified in the Technical Specifications.

4.02 Site Investigation and Conditions Affecting the Work

- A. By submitting a Bid Proposal and executing the Agreement, Contractor agrees it has taken all steps reasonably necessary to ascertain the nature and location of the Work, and it has fully investigated and satisfied itself as to the general and local conditions which can affect the Work or its cost, including but not limited to:
1. Conditions bearing upon transportation, disposal, handling, and storage of materials.
 2. Availability of labor, water, electric power, and roads.
 3. Uncertainties of weather, river stages, groundwater quantity and quality, or similar physical conditions at the site.
 4. Conformation and conditions of the ground.
 5. Character of equipment and facilities needed preliminary to and during work performance.
- B. The Contractor also acknowledges that it has satisfied itself as to the character, quality, and quantity of surface and subsurface materials or obstacles to be encountered insofar as this information is reasonably ascertainable from an inspection of the site, including from the Drawings and Specifications made a part of the Contract Documents. Contractor acknowledges that the primary geologic formation underlying the surface of the Truckee Meadows is the Tahoe Outwash consisting primarily of cohesionless soils, cobbles and boulders typically classified as OSHA Type C soils. As such, the Contractor should anticipate significant sloughing of trench walls and acknowledges it has included in the Contract Sum all costs to complete the Work in this environment, including without limitation possibilities of substantial shoring requirements, slower production rates, increased bedding and backfill quantities, increased trench width and increased pavement patching requirements inherent to trenching and excavating under these soil conditions. Any failure of the Contractor to take actions described and acknowledged in this clause will not relieve the Contractor from responsibility for estimating properly the difficulty and cost of successfully performing the work, or for proceeding to successfully perform the work without additional expense to TMWA.
- C. TMWA assumes no responsibility for any conclusions, assumptions or interpretations made by the Contractor based on the information made available by TMWA.
- D. TMWA assumes no responsibility for any understanding reached or representations made concerning conditions, which can affect the work by any of its officers or agents before the execution of the Agreement, unless the understanding or representation is expressly stated in the Contract Documents.
- E. Reports or other information associated with geotechnical investigations or other subsurface exploratory work made available to the Contractor by TMWA are not a part of the Contract Documents and are made available for information only. Contractor acknowledges the information provided by TMWA is provided for informational purposes only, without representation or warranty of any kind with respect to its accuracy or completeness, and is not intended to and shall not be relied upon as a substitute for, or a supplement to, the independent investigation by the Contractor of site conditions. The Contractor is cautioned that soils information from test pit logs may not represent homogenous subsurface conditions throughout the site of the work. Refer to the Supplementary Conditions for additional information on any geotechnical reports that may have been prepared for the Project.

4.03 Differing Conditions

- A. For responsibility relating to locating and repairing existing underground facilities or utilities, see Section 6.04. Submittal of a Bid Proposal is prima facie evidence that the Contractor has sufficient specific experience of a similar nature to the Project to recognize conditions inherent to, or normally encountered in, the performance of such work, including providing sufficient costs in its Bid Proposal price to account for those conditions in order to complete the work as intended. For installation of underground facilities, such inherent conditions may include, but are not limited to:
1. Existing underground utility lines.
 2. Groundwater depth, quality, and seasonal variation of these items.
 3. Where underground facilities are installed parallel to existing facilities, normally encountered conditions may include excavation through unstable select granular or rock backfill, accompanied by resultant trench sloughing, increased trench width and additional paving.
 4. The presence of rock and boulders in the vicinity of the Truckee River. Refer to Article 4.06 “Rock Excavation” of the General Conditions for additional details.
- B. During the progress of the Work, if unknown subsurface or latent physical conditions are encountered at the site which differ materially from those indicated in the Contract Documents or inherent in the Work described in the Contract Documents are encountered at the site, or if unknown physical conditions of an unusual nature, differing materially from those ordinarily encountered or generally recognized as inherent in the Work provided for in the Contract Documents, are encountered at the site, Contractor shall immediately notify the Project Representative in writing of the specific differing conditions before the conditions are disturbed and before the affected portion of the Work is performed. Following receipt of written notification, TMWA will investigate the site conditions promptly after receiving the notice. Contractor waives and shall have no claim for additional compensation for standby time while such investigation is conducted. If TMWA determines in its sole discretion that the conditions materially differ from those identified in the Contract Documents, those inherent in the Work, or those ordinarily encountered, and such differences cause an increase or decrease in the Contractor’s cost or the time required for the performance of any part of the Work under the Contract Documents, an adjustment (excluding loss of anticipated profits) shall be made by TMWA and the Contract Documents modified in writing accordingly. No request for contract adjustment which results in a benefit to the Contractor will be allowed unless the Contractor has provided the required written notice. No request for an adjustment will be allowed after final payment under the Contract Documents.

No Contractor claims of “lost production”, or “delay” will be considered, unless Contractor and Project Representative agree, at the job site at the time of the investigation by Project Representative, upon the number, type and hours of labor and equipment actually delayed by the unforeseen or unknown condition. Said agreement must be documented by Project Representative’s and Contractor’s signature on Contractor’s Daily Extra Work Report as required by Article 7.03 “Extra Work – Request for Approval” and Article 7.04 “Extra Work – Payment for Time and Material Work” of the General Conditions.

4.04 Reference Points

- A. TMWA will provide engineering surveys to establish reference points for construction, which in TMWA's judgment are necessary to enable Contractor to proceed with the work.
- B. Contractor shall report to Project Representative whenever any reference point is lost or destroyed or requires relocation because of necessary changes in grades or locations, and shall be

responsible for the accurate replacement or relocation of such reference points by professionally qualified personnel.

- C. Unless otherwise specified in the Technical Specifications, Contractor shall be responsible for laying out the work (all construction staking), shall protect and preserve the established reference points, and shall make no changes or relocations without the prior written approval of TMWA.

4.05 Hazardous Environmental Conditions

- A. In the event the Contractor encounters on the site material reasonably believed to be asbestos, petroleum products, or any other material subject to regulation by laws or regulations (hereinafter "Hazardous Materials") which has not been rendered harmless, the Contractor shall immediately stop work in the area affected and report the condition to TMWA in writing. The work in the affected area shall not be resumed until the hazardous material is removed or rendered harmless.
- B. The Contractor will not be required to perform any work relating to hazardous materials. In proportion to its negligence, but in no event exceeding liability limitations created pursuant to NRS Chapter 41, TMWA will indemnify and hold harmless the Contractor and its employees, from and against claims, damages, losses, and reasonable expenses, including but not limited to reasonable attorney's fees, directly resulting from TMWA's negligence in discharging or knowingly failing to disclose the presence of Hazardous Materials in the Contractor's work area.
- C. The Contractor shall not knowingly incorporate into the site or into any building, building component or structure, or otherwise leave on site any Hazardous Materials.
 - 1. If the Contractor discovers any such Hazardous Materials either on site or incorporated in the Work, it shall in writing immediately notify TMWA who shall take appropriate action to alleviate the problem.
 - 2. TMWA may require the Contractor to furnish, from time to time, a certification that to the best of the Contractor's knowledge and belief it has not incorporated into the site or building any hazardous materials.
- D. To the fullest extent permitted by law, the Contractor shall indemnify, defend, protect, and hold harmless TMWA, its agents and employees from and against claims, damages, losses, liabilities, and expenses, including but not limited to attorneys' fees, arising out of or resulting from the Contractor, its agents, employees, or anyone for whose acts Contractor may be liable, knowingly or negligently incorporating into the site or the work or leaving on the site any Hazardous Materials. Such indemnity obligation shall not negate, abridge, or reduce any other rights or obligations of indemnity, which would otherwise exist.
- E. A Material Safety Data Sheet (MSDS) must accompany all chemicals to be used on the project site. No chemical shall be off-loaded on the project site until the appropriate MSDS has been delivered to the Project Representative.
- F. It is the Contractor's responsibility to:
 - 1. Dispose of all chemicals and their by-products per State and Federal regulations.
 - 2. Remove all unused chemicals and products from the site at the completion of the Work.
 - 3. Ensure that all containers are labeled in accordance with DOT, NFPA and OSHA standards.
 - 4. Ensure that all potential hazards are appropriately marked or placarded in compliance with OSHA and TMWA standards.
 - 5. Adhere to all posted warning signs.
- G. Contractor may be required to handle, disturb or remove certain water pipes constructed of transite and asbestos containing materials regulated as a potentially hazardous material as part of the Work Asbestos or transite pipe which has not been cut or damaged or which is not tapped,

cut, damaged or removed during performance of the Work, shall not be deemed “Hazardous Materials” for purposes of these General Conditions. If the Contractor is required to cut, remove or tap transite or asbestos pipe as part of the Work, or if the Contractor otherwise damages or cuts transite or asbestos pipe during the Work, Contractor must utilize the services of personnel or a subcontractor that has received specialized OSHA training in the handling and disposal of asbestos to perform any work on such pipe, including cutting, tapping, repairing or removing. TMWA must be provided with chain of custody forms for all transite or asbestos pipe disposed of by Contractor or its subcontractors. Any disturbance, removal, disposal, handling or work activity on transite pipe must be done in strict compliance with applicable laws and regulations governing the safe handling practices for disturbance, removal, handling and disposal of asbestos-containing material, and Contractor shall be solely responsible for all costs and actions necessary to comply with such laws and regulations. Contractor shall provide the disposal manifest to the TMWA inspector showing all transite pipe material has been disposed of in accordance with all applicable laws and regulations. Contractor shall indemnify and hold TMWA harmless from any claims, injuries, demands or liabilities arising from Contractor’s handling, removal, disposal or work on or about transite pipe.

4.06 Rock Excavation

A. The term “Rock excavation” is defined as:

1. For trench excavation, rock excavation is excavation of all solid rock in place that cannot be removed by power equipment equivalent, or larger, in weight, engine power, and bucket force to a Caterpillar 345C L Hydraulic Excavator equipped as follows.
 - i. Caterpillar 1.8 cubic yard heavy duty rock bucket with 4 teeth.
 - ii. 22’-8” reach boom with a 12’-10” stick and 16,780 lb. counterweight.
2. For mass grading, rock excavation is excavation of all solid rock in place that cannot be removed by power equipment equivalent, or larger, in weight, engine power, vertical shank penetration force, and pry out force to a Caterpillar D8T Track-type Tractor equipped with a single shank, standard depth, ripper tooth.
3. For all excavations, rock excavation is excavation of boulders or detached pieces of rock greater than 54 cubic feet in volume.

The term “rock excavation” does not include or apply to any trenchless installation, including but not limited to, jack and bore installation, auger boring, tunneling, directional drilling, and similar types of construction methods. Due to the obvious presence of rock and boulders in the vicinity of the Truckee River, which Contractor acknowledges, the term “rock excavation” also does not include or apply to, nor will any associated unit adjusting price apply to, excavation and trenching performed within two hundred feet either side of the approximate centerline of the Truckee river channel.

B. If rock is encountered such that Contractor believes rock excavation, as defined above, is required, the Contractor shall notify the Project Representative in writing. If the Project Representative agrees that rock excavation is required, rock excavation will be paid for at the price per cubic yard for rock excavation (trench excavation) and/or rock excavation (mass grading) submitted in the Bid Proposal, as applicable.

1. Payment for any category of rock excavation will be in addition to the lump sum or unit prices for the Work submitted in the Bid Proposal.

2. Payment for rock excavation of boulders or detached pieces of rock greater than 54 cubic feet in volume will be paid for at the price per cubic yard for rock excavation (trench excavation) submitted in the Bid Proposal.
3. The Contractor will not be eligible for any additional payment for rock excavation associated with the Work wherever solid rock can be seen from the surface, or where indicated from geotechnical test pit investigations.

If there are no bid items covering rock excavation of the type encountered, payment for approved rock excavation will be made in accordance with Article 7.03 “Extra Work – Request for Approval” and Article 7.04 “Extra Work – Payment for Time and Material Work” of the General Conditions.

- C. Blasting will be permitted when the Contractor and the Project Representative agree that it is more cost effective and/or more practical than other methods of rock excavation.
1. The entire cost associated with rock excavation by blasting shall be paid for in accordance with Article 7.03 “Extra Work – Request for Approval” and Article 7.04 “Extra Work – Payment for Time and Material Work” of the General Conditions. No additional payment for blasting will be made for any category of rock excavation listed in the Bid Proposal, and no adjustment will be made in lump sum or unit prices for the Work submitted in the Bid Proposal.
 2. Blasting operations shall be carried out by person’s duly licensed and insured, including but not limited to workers’ compensation, general liability, and business automobile liability with limits no less than those set forth in Article 5.02 “Contractor’s Insurance” of the General Conditions, to work with explosives and shall be in compliance with all applicable laws and ordinances.
 3. Blasting will be permitted only when proper precautions are taken for protection of persons, work, and structures.
 4. The Contractor shall be strictly liable, and shall defend, protect, indemnify, and hold harmless TMWA for any damage to persons, property, the Work, or structures arising or in connection with blasting activities, even if such damage is caused in whole or in part by its Subcontractor(s).
 5. The Contractor shall be responsible for obtaining all permits required for blasting and shall furnish copies of the permits and current copies of the blaster’s license and insurance, including any and all endorsements reflecting valid and collectible insurance coverage is in place to protect the interests of TMWA and Contractor as an additional insured in accordance with Article 5.02 “Contractor’s Insurance” of the General Conditions and any other applicable requirement specified hereunder. The Contractor shall provide this complete evidence of insurance to the Project Representative at least 24 hours prior to commencement of blasting.

Article 5 Bonds and Insurance

5.01 Performance and Payment Bonds

- A. The Contractor shall furnish Performance and Payment Bonds, issued by a “T” listed bond company acceptable to TMWA, signed or countersigned by an agent licensed by the State of Nevada as required by NRS 680A.300, each in the amount of 100 percent of the Contract Sum as security under the Contract Documents for faithful performance and payment of all obligations under the Contract Documents, including but not limited to warranty obligations. Contractor shall furnish such bonds to TMWA no later than ten (10) calendar days after receipt of the Notice of Award.
- B. If the surety on any bond becomes insolvent or its right to do business is terminated, the Contractor shall provide another bond and surety, acceptable to TMWA within seven days.
- C. The Bonds shall remain in effect for a period of one year from the date of final acceptance of the Project by TMWA.
- D. The cost of additional bond premiums for change order increases shall be a pass through cost to TMWA for the actual amount of the additional bond premiums.

5.02 Contractor’s Insurance

- A. Contractor shall, at Contractor’s sole expense, procure, maintain and keep in force the following insurance and pay all taxes and fees incident hereunto. The required insurance shall be in effect prior to the commencement of work by Contractor. TMWA shall have no liability except as specified in this Agreement. Contractor shall contractually require all of its Subcontractors to procure, maintain and provide evidence of insurance coverage with limits no less than those required herein. Contractor shall furnish evidence of such insurance to TMWA no later than ten (10) calendar days after receipt of the Notice of Award.
- B. Any insurance or self-insurance available to TMWA shall be excess of and non-contributing with any insurance required from Contractor. Contractor’s insurance policies shall apply on a primary basis. Until such time as the insurance is no longer required by TMWA, Contractor shall provide TMWA with renewal or replacement evidence of insurance no less than 30 days before the expiration or replacement of the required insurance. If at any time during the period when insurance is required by the Agreement, an insurer or surety shall fail to comply with the requirements of this Agreement, as soon as Contractor has knowledge of any such failure, Contractor shall immediately notify TMWA and immediately replace such insurance or bond with an insurer meeting the requirements.
- C. By endorsement to all liability policies, except Worker’s Compensation and Professional Liability, evidenced by Contractor, TMWA, its officers, employees and immune Contractors as defined in NRS 41.0307, if any, shall be named as additional insured for all liability arising from the Agreement using the unmodified ISO additional insured endorsement CG 20 10 11/85 or a substitute providing coverage at least as broad, and under the commercial umbrella, if any. This insurance shall apply as primary insurance with respect to any other insurance or self-insurance programs afforded to TMWA. Additional insured status for TMWA shall apply until the expiration of time within which a claimant can bring suit per applicable state law.
- D. Each liability insurance policy, including but not limited to commercial general liability, business automobile liability, workers’ compensation, pollution and professional liability, shall be endorsed to provide that the insurance company waives all right of recovery by way of subrogation against TMWA, its officers, agents, employees, agents, and immune contractors in connection with damage covered by any policy.

- E. Insurance maintained by Contractor shall apply for those named as additional insured on a first dollar basis without application of a deductible or self-insured retention. The Contractor shall be responsible for satisfying any deductible or self-insured retention. Any deductible or self-insured retention shall not exceed \$5,000 per occurrence. There shall be no provision providing that the self-insured retention or deductible can only be satisfied by the named insured.
- F. Each insurance policy shall be:
1. Issued by insurance companies authorized to do business in the State of Nevada or eligible surplus lines insurers acceptable to TMWA and having agents in Nevada upon whom service of process may be made, and
 2. Currently rated by A.M. Best as “A X” or better.
- G. Policies required:
1. Workers’ Compensation and Employer’s Liability Insurance. Contractor shall provide proof of worker’s compensation insurance as required by NRS 616B.627 or proof that compliance with the provisions of Nevada Revised Statutes, Chapters 616A-D and all other related chapters is not required. The Employers Liability limits shall not be less than \$1,000,000 each accident for bodily injury by accident and \$1,000,000 each employee for bodily injury by disease. If Contractor’s employees are exposed to bodily injury under the U.S. Longshoreman and Harbor Workers’ Compensation Act, the Jones Act, or under any and all applicable laws, regulations or statutes applicable to maritime employees, coverage shall be included for such claims or injuries.
 2. Commercial General Liability Insurance. Contractor shall procure and maintain, during the term of this Agreement, occurrence commercial general liability insurance for limits of not less than \$2,000,000 for bodily injury and property damages, per occurrence, \$2,000,000 products and completed operations aggregate, and \$2,000,000 general aggregate. Coverage shall be written on an occurrence form at least as broad as an unmodified ISO occurrence form CG 00 01 12 04 (or a substitute form providing coverage at least as broad) and shall cover liability arising from premises, operations, independent contractors, products-completed operations liability, personal and advertising injury, products, civil lawsuits, Title VII actions and liability assumed under an insured contract (including the tort liability of another assumed in a business contract). There shall be no endorsement or modification of the Commercial General Liability policy limiting the scope of coverage for liability arising from pollution, explosion, collapse, underground property damage, and employment-related practices.
 3. Business Automobile Liability Insurance. Contractor shall procure and maintain, during the term of this Agreement, business automobile liability insurance in the amount of not less than \$2,000,000 per occurrence for bodily injury and property damage. Coverage shall be for “any auto”, including owned, non-owned and hired vehicles. Business auto coverage shall be written on any of the unmodified ISO forms (CA 00 01, CA 00 05, CA 00 12, CA 00 20), or a substitute form providing coverage at least as broad. If necessary, the policy shall be endorsed to provide contractual liability coverage equivalent to that provided in the 1990 and later editions of CA 00 01.
 4. Contractors Pollution Liability Insurance. Pollution coverage is required if any exposure exists from Contractor’s Work performed under this Agreement. If required, coverage shall be \$1,000,000 per occurrence and \$2,000,000 aggregate for any exposure to “hazardous materials” as this term is defined in applicable law, including but not limited to waste, asbestos, fungi, bacterial or mold.
- H. Prior to the start of any work, Contractor shall provide the following documents to TMWA, Attention: Purchasing & Contracts, P.O. Box 30013, Reno, NV 89520-3013:

1. Certificate of Insurance. Contractor shall provide a Certificate of Insurance form to TMWA to evidence the insurance policies and coverage required of Contractor. All certificates shall provide for 30 days written notice to TMWA prior to the cancellation or material change of any insurance referred to therein. The words “endeavor to” and “but failure to mail such notice shall impose no obligation or liability of any kind upon the company, its agents or representatives” shall be deleted from the certificate form’s cancellation provision.
 2. Additional Insured Endorsements. An original Additional Insured Endorsement, signed by an authorized insurance company representative, must be submitted to TMWA, by attachment to the Certificate of Insurance, to evidence the endorsement of TMWA as additional insured.
 3. Policy Cancellation Endorsement. Except for ten days’ notice for non-payment of premium, each insurance policy shall be endorsed to specify that without 30 days prior written notice to TMWA, the policy shall not be cancelled, non-renewal or coverage and/or limits reduced or materially altered, and shall provide that notices required by this paragraph shall be sent by certified mailed to the address specified above. A copy of this signed endorsement must be attached to the Certificate of Insurance.
- I. Compliance with the insurance requirements of this Agreement shall not limit the liability of Contractor or its Subcontractors, employees or agents to TMWA or others, and shall be in addition to and not in lieu of any other remedy available to TMWA under this Agreement or otherwise. TMWA reserves the right to request and review a copy of any required insurance policy or endorsement to assure compliance with these requirements.

5.03 Property Insurance

- A. If required by the Supplementary Conditions, Contractor shall provide builder’s risk insurance on an “all risk” basis on a policy form satisfactory to TMWA. The limit of coverage shall be the amount necessary to cover the Contract Sum of any structure or improvement in the Contract Documents, and TMWA shall be a named insured on the builder’s risk policy.
- B. All losses paid under property insurance policies shall be paid directly to TMWA by the insurer.

Article 6 Contractor’s Responsibilities

6.01 Laws and Regulations

- A. The Contractor shall comply strictly with all laws and regulations.
- B. Contractor shall not under any circumstances apply to or enter into negotiations with any governmental authority or agency for acceptance of variations from or revisions to safety, health, air, water, noise, pollution, laws or regulations relating to the Contract Documents without TMWA’s prior written approval.

6.02 Supervision of the Work and Subcontractors

- A. Contractor shall supervise and direct the work competently and efficiently, devoting such attention thereto and applying such skills and expertise as may be necessary to perform the work in accordance with the Contract Documents.
- B. Contractor shall be responsible to see that the finished work complies accurately with the Contract Documents. Approved copies of shop drawings and submittals shall be on site as required by the construction operation in progress.
- C. All times during performance under the Contract Documents and until the work is completed and accepted, the Contractor shall directly superintend the work or assign and have on the work site a competent Superintendent who is satisfactory to TMWA, and has authority to act for the

Contractor. Any direction given Superintendent by Project Representative shall be binding as if given directly to Contractor.

1. Contractor's Superintendent shall be experienced in the type of construction required by the Work as evidenced by at least five years of experience at a supervisory level on similar projects within the preceding ten years.
 2. Submit Superintendent's resume to the Project Representative for approval prior to the issuance of the Notice To Proceed.
 3. If the Superintendent is changed during the Contract Time, the replacement Superintendent shall be subject to the same approval as the original Superintendent.
- D. Contractor shall be directly responsible for supervising, scheduling and coordinating the work of all Subcontractors and Suppliers and for the acts and omissions of all Subcontractors and Suppliers. Contractor's Superintendent shall be present at the site of the Work at all times when work is in progress or materials are being delivered.
- E. All work performed for Contractor by a Subcontractor will be pursuant to an appropriate agreement between Contractor and the Subcontractor which specifically binds the Subcontractor to the applicable terms and conditions of the Contract Documents for the benefit of TMWA, including but not limited to the required insurance and indemnity provisions.
- F. Contractor shall be solely responsible for the means, methods, techniques, sequences, and procedures of construction, as long as the aforementioned does not interfere with TMWA's facilities, but Contractor shall not be responsible for the negligence of TMWA or TMWA's consultants in the design or selection of a specific means, method, technique, sequence, or procedure of construction which is indicated in and required by the Contract Documents.

6.03 Contractor Personnel

- A. In selecting employees to undertake the Work under the Contract Documents, Contractor shall select only those persons who are qualified by the necessary education, training and experience to provide high quality performance of the particular work for which each employee is responsible.
- B. The Contractor shall be responsible for insuring that all personnel installing or maintaining TMWA facilities are trained to perform the work in accordance with applicable Standards.
- C. Due to the critical nature of TMWA's operations, Contractor agrees that if TMWA, in its sole discretion, determines that any Contractor employee is unsuitable for the performance of the Work under the Contract Documents, or that the continued presence of such employee is not consistent with the best interests of TMWA, then in such instance TMWA may request that the Contractor remove such employee from the Work. Contractor shall then immediately replace such employee with an employee who fully meets the standards under the Contract Documents and will do so at no additional cost to TMWA.

6.04 Location of Underground Facilities

- A. The information and data shown or indicated in the Contract Documents with respect to existing underground facilities at or contiguous to the site is based on information and data furnished to TMWA by the owners of such underground facilities or by others. TMWA is not responsible for the accuracy or completeness of any such information or data and is not intended to and shall not be relied upon as a substitute for, or a supplement to, the independent investigation by the Contractor of site conditions. Contractor agrees that underground utilities may possibly exist which are not known to TMWA or which are in a location different from that which are shown in the Contract Documents, and locating all underground facilities is the sole responsibility of Contractor.

- B. Contractor shall have sole responsibility for the following listed items, the cost of which shall be considered as having been included in the Contractor's Bid Price:
 - 1. Reviewing and checking all such information and data.
 - 2. Locating all underground facilities shown or indicated in the Contract Documents.
 - 3. Notification to and coordination with the owners of such underground facilities during construction.
 - 4. Safety and protection thereof and repairing any damage thereto arising out of the Work.
- C. The Contractor shall be responsible for obtaining underground facilities location services and complying with all provisions set forth in NRS Chapter 455 (call before you dig service).
- D. The Contractor is responsible for conducting separate "potholing" of existing underground facilities far enough in advance of the main work to identify conflicts and allow modification in the horizontal and vertical alignment of the new installation with minimal impact to cost or schedule.
- E. The Contractor shall be solely responsible for all damages to persons or property that occur as a result of the Contractor's operations in locating underground facilities, for safeguarding all existing facilities and for the prompt repair, replacement and reconnection of all facilities damaged during construction. Contractor agrees that notwithstanding any compliance with NRS 455, Contractor shall indemnify and hold TMWA harmless from any claims, liabilities, costs or expenses related to the repair, replacement or reconnection of underground facilities arising in connection with the Work.
- F. Contractor acknowledges and agrees the Contract Sum includes all Work associated with any repair or replacement of existing utility services encountered during construction. The Contractor assumes all risk for services that were not physically located during potholing operations or for not reconnecting those facilities that are encountered but reported to be abandoned.
- G. Contractor acknowledges the difficulty of locating existing underground sanitary sewer laterals and acknowledges that said laterals have been constructed to each private property parcel adjacent to the public right-of-way. As such the Contractor acknowledges the possibility that said laterals will be damaged during Contractor's trenching operations and Contractor has included adequate costs in his bid proposal to repair and replace all sanitary sewer laterals that may be encountered.

6.05 Materials

- A. All equipment and materials required by the Contract Documents shall be furnished by the Contractor except items specifically designated in the Specifications or noted on the Drawings as TMWA furnished.
- B. All equipment, material, and articles incorporated into the Work shall be new and of most suitable grade for the purpose intended, unless otherwise specifically provided in the Contract Documents.
- C. The Contractor shall be responsible for properly storing and protecting all materials delivered to the site, including TMWA furnished materials. Materials damaged while in the care, custody, or control of the Contractor shall be replaced at the Contractor's expense.
- D. Contractor furnished materials that are at any time found to be defective, or otherwise not suitable for the purpose intended, shall be replaced by the Contractor at Contractor's expense whether installed or not.
- E. All Contractor-furnished materials shall be shipped FOB to the site of the work.

6.06 Permits

- A. Unless otherwise specified in the Supplementary Conditions or the Technical Specifications, the Contractor shall apply for, obtain and pay all required fees for the following permits to the extent required for the construction of the Project:
1. Permits required to enter, perform and complete the work in a public rights-of-way. These may include, but are not limited to, street cut permits, excavation permits, permits for installation of temporary traffic control devices, including preparation of traffic control plans, and similar permits. Notwithstanding Contractor's obligation to obtain such permits, TMWA will pay any required street cut penalties.
 2. City of Reno stockpiling permits.
 3. Construction site stormwater permits. Refer to Article 6.14 "Construction Site Stormwater Control" of the General Conditions for detailed requirements.
- B. Unless otherwise specified in the Supplementary Conditions or the Technical Specifications, TMWA will obtain the following permits and pay all required fees:
1. Occupancy permits from NDOT, the railroad, or local governments (where applicable) that grant TMWA rights to operate and maintain facilities in such rights of way following the completion of the Work.
 2. Health Department water project permits.
 3. Building permits.
 4. Dust control permits.
 5. Special use permits and other local planning agency permits except City of Reno stockpiling permits.
 6. Other State and federal permits, except for construction site stormwater permits which shall be obtained by the Contractor.
- C. The Contractor shall comply with the terms and conditions of all permits, licenses, and authorizations whether obtained by TMWA or the Contractor.
- D. Additional details of permitting requirements may be included in the Supplementary Conditions or Technical Specifications.

6.07 Submittals for Items That Will Be Incorporated Into the Work

- A. Items to be submitted will be specified in the Technical Specifications and may include Shop Drawings, calculations, catalog cuts, samples, and other descriptive material required to fully describe the item or items being provided.
1. Submittals shall be clearly identified and the data furnished shall be complete with respect to quantities, dimensions, specified performance and design criteria, materials, equipment accessories, and similar data to enable TMWA to review the information as required.
 2. Limit the information being provided to the specific item covered by the submittal.
 3. Clearly indicate the item being submitted by highlighting, circling, or other marks when using catalog cut sheets. Submittals not so marked will not be reviewed and will be returned to the Contractor for marking and resubmittal.
 4. Specific formatting requirements for submittals are specified in the Technical Specifications. If no format for the submittal is specified in the Technical Specifications, provide the submittal in the Contractor's standard format.
- B. The Contractor shall review each submittal prior to transmittal for compliance with the Drawings and Specifications and shall have determined and verified all quantities, dimensions, specified performance criteria, installation requirements, materials, catalog numbers, and similar data with

respect thereto and reviewed or coordinated each submittal with other submittals and with the requirements of the Work.

1. Each submittal shall bear a cover sheet verifying that the Contractor has satisfied Contractor's responsibilities under the Contract Documents with respect to the review of the submission.
 2. The cover sheet shall include as a minimum the following information.
 - i. Project name.
 - ii. Submittal number.
 - iii. Date of Contractor's approval.
 - iv. Notice of each variation in the submittal from the requirements of the Contract Documents.
 - v. A statement certifying that the submittal has been reviewed for and found to be in compliance with the Contract Documents except for variations noted.
 - vi. Contractor's reviewer name and signature.
 3. Submittals that do not have the completed cover sheet attached with Contractor's signature will not be reviewed and will be returned to the Contractor for attachment of the cover sheet and resubmittal.
- C. Contractor shall submit to TMWA for review and approval six copies of all submittals unless a different number is specified in the Technical Specifications.
- D. Submittals shall be made sufficiently in advance of construction to allow for review. In no case shall less than 15 working days be allowed for review and approval of any submittal or resubmittal unless otherwise specified in the Supplementary Conditions or Technical Specifications. No extension of Contract Time will be allowed because of the Contractor's failure to transmit submittals in a timely manner.
- E. TMWA will review and approve submittals with reasonable promptness, but TMWA's review and approval will be only for conformance with the design concept of the Project and for compliance with the information given in the Contract Documents and shall not extend to means, methods, techniques, sequences, or procedures of construction (except where a specific means, method, technique, sequence, or procedure of construction is indicated in or required by the Contract Documents) or to safety precautions or programs incident thereto.
1. The review and approval of a separate item as such will not indicate approval of the assembly in which the item functions.
 2. Contractor shall make corrections required by TMWA, and shall return the required number of corrected copies as a resubmittal.
 3. On resubmittals, Contractor shall direct specific attention in writing to revisions other than the corrections called for by TMWA on previous submittals.
 4. Submittals will be marked in one of six ways.
 - i. Approved as Submitted.
 - ii. Approved as Noted.
 - iii. Disapproved Make Corrections – Resubmittal Required.
 - iv. Disapproved as Noted Develop Replacement – Resubmittal Required.
 - v. Incomplete. Complete and Resubmit – Resubmittal Required.
 - vi. Incomplete. Submit Missing Portions – Resubmittal Required.
 5. Submittal comments will be furnished in memo form, written directly on the submittal, or both.
 6. Two copies of each submittal with review comments will be returned to the Contractor.
- F. One initial submittal and one resubmittal for each subject will be reviewed by Project Representative and Engineer at no cost to Contractor.

1. Subsequent resubmittals will be reviewed at an hourly cost of ninety dollars to the Contractor.
 2. The aggregate amount owed by Contractor shall be deducted from moneys owed Contractor by Change Order after completion and acceptance of the Work.
- G. TMWA's review and approval of submittals shall not relieve Contractor from responsibility for any variation from the requirements of the Contract Documents unless Contractor has in writing called TMWA's attention to each such variation at the time of submission as required above and TMWA has given written approval of each such variation by a specific written notation thereof incorporated in or accompanying the submittal approval; nor will any approval by TMWA relieve Contractor from responsibility for errors or omissions in the Shop Drawings or from responsibility for having complied with the provisions of this Article.
- H. Where a submittal is required by the Specifications, any related Work performed prior to TMWA's review and approval of the pertinent submission will be the sole expense and responsibility of Contractor.
- I. TMWA may duplicate, use and disclose in any manner and for any purpose submittals and shop drawings delivered under the Contract Documents.

6.08 Submittals for Other Items

- A. Items to be submitted will be specified in the Technical Specifications and may include certificates, photographs, manufacturer's instructions, operation and maintenance instructions and manuals, schedules, guarantees, material testing and inspection reports, training agenda, and similar items.
- B. The number of copies to be submitted and the format of the submittal may be specified in the Technical Specifications.
1. Submit four copies of each required submittal if no number is specified in the Technical Specifications.
 2. If no format for the submittal is specified, provide the submittal in Contractor's standard format.

6.09 "Or Equal" Items

- A. In accordance with NRS 338.140, whenever materials or equipment are specified or described in the Contract Documents by using the names of proprietary items or the names of particular Suppliers, the naming of the item is intended to establish the type, function, and quality required and at least two items will be named. The words "or equal", whether explicitly stated or not, are understood to follow the names of proprietary items except as provided below.
- B. Where the name of a proprietary item or particular Supplier is followed by the words "or equal," materials or equipment of other Suppliers may be accepted by TMWA only if sufficient information is submitted by Contractor to allow TMWA to determine that the material or equipment proposed is equivalent or equal to that named.
- C. Where the name of a proprietary item or particular Supplier is followed by words "no equal," no substitution is permitted. Per the provisions of NRS 338.140 paragraph 1(b), the "no equal" specification will be used only when it is necessary to provide the exact product to match existing equipment, to minimize spare parts inventory, or when in TMWA's opinion no equal product exists.

6.10 Substitutions

- A. Requests for review of substitute items of material and equipment will not be accepted by TMWA from anyone other than the Contractor.
- B. If Contractor wishes to furnish or use a substitute item of material or equipment, Contractor shall make written application to TMWA for acceptance thereof, certifying that the proposed substitute will perform adequately the functions and achieve the results called for by the general design, be similar and of equal substance to that specified, and be suited to the same use as that specified.
 - 1. The application shall state that the evaluation and acceptance of the proposed substitute will not prejudice Contractor's achievement of completion on time, whether or not acceptance of the substitute for use in the work will require a change in any of the Contract Documents to adapt the design to the proposed substitute and whether or not incorporation or use of the substitute in connection with the work is subject to payment of any license fee or royalty.
 - 2. All variations of the proposed substitute from that specified shall be identified in that application and available maintenance, repair, and replacement service shall be indicated.
 - 3. The application shall also contain an itemized estimate of all costs that will result directly or indirectly from acceptance of such substitute, including costs of redesign and claims of other Contractors affected by the resulting change, all of which shall be considered by TMWA in evaluating the proposed substitute.
 - 4. TMWA may require Contractor to furnish, at Contractor's expense, additional data about the proposed substitute.
- C. If a specific means, method, technique, sequence, or procedure of construction is indicated in or required by the Contract Documents, Contractor may furnish or utilize a substitute means, method, sequence, technique, or procedure of construction acceptable to TMWA, if Contractor submits sufficient information to allow TMWA to determine that the substitute proposed is equivalent to that indicated or required by the Contract Documents. The procedure for review by TMWA will be similar to that provided in the paragraph above.
- D. TMWA will be allowed a reasonable time within which to evaluate each proposed substitute.
- E. The Project Representative will be the sole judge of acceptability, and no substitute will be ordered, installed, or utilized without TMWA's prior written acceptance, which will be evidenced by either a Change Order or an approved submittal.
- F. TMWA may require Contractor to furnish at Contractor's expense a special performance guarantee or other surety with respect to any substitute. TMWA's employees and/or consultants will record time required to evaluate substitutions proposed by Contractor and in making change in the Contract Documents occasioned thereby. Whether or not TMWA accepts a proposed substitute, Contractor shall reimburse TMWA for the charges of employees and/or TMWA's consultants for evaluating each proposed substitute.

6.11 Worker Safety and Accident Prevention

- A. The Contractor shall comply with all OSHA and TMWA safety requirements. Failure to comply may result in Termination for Default.
- B. The Contractor shall plan and direct the performance of the Work in compliance with reasonable safety and work practices and applicable federal, state and local laws, rules and regulations.
- C. The Contractor shall be responsible for initiating, maintaining and supervising all safety precautions and programs in connection with the Contract Documents. The presence of the Project Representative, TMWA inspectors, or other TMWA employees at the site of the Work shall in no way diminish or eliminate that responsibility.

1. Hard hats, shirts, long pants, and work boots are mandatory on all work sites.
 2. Contractor's personnel shall have safety training appropriate for the work being performed.
 3. It is the Contractor's responsibility to ensure that Contractor's personnel have and use the proper personal safety equipment appropriate for the work being performed.
 4. Job site safety meetings shall be conducted by the Contractor as necessary to maintain worker awareness of safety requirements and procedures.
- D. The Contractor shall at all times have in their possession and maintain/calibrate gas detector units capable of monitoring oxygen and carbon dioxide and combustibles per OSHA confined space requirements. The Contractor's personnel shall be trained in confined space rescue operations.
- E. The cost of all personal or crew safety equipment shall be included in Contractor's overheads and shall not be direct billed on any invoice for extra work under the Contract Documents.
- F. The Contractor shall immediately report to TMWA any OSHA Recordable accident or vehicle accident occurring during performance of the Work.
1. Contractor shall fully cooperate with TMWA and any other agency investigating accidents, which occur during performance of the Work under this contract, including interviews of Contractor's personnel.
 2. As soon as practical following any accident occurring during performance of the Work under this contract, the Contractor's personnel involved in the accident shall be tested for prohibited drugs and alcohol use.
 3. Contractor's personnel shall be relieved of safety sensitive duties pending results of the post-accident drug and alcohol testing. Post-accident drug and alcohol test results shall be provided to TMWA's Designated Official responsible for administration of TMWA's Drug and Alcohol Policy.
 4. Failure of Contractor's personnel to submit to post-accident drug and alcohol testing will result in permanent removal (and replacement) of such employee from the Work for the duration of this contract.
- G. The Drug Free Workplace Act of 1988 requires Contractors and Subcontractors of TMWA to maintain a workplace free of drugs and alcohol.
1. The unlawful manufacture, distribution, possession or use of a controlled substance or alcohol is prohibited in TMWA's workplace or job sites.
 2. The Contractor will be required to remove any of its employees or its Subcontractor's employees suspected by Contractor or TMWA of being under the influence of drugs or alcohol.
- H. Contractor 's personnel performing work near live gas facilities with the intent to uncover or expose such gas facilities shall meet all DOT drug and alcohol testing requirements.
1. Furthermore, Contractor 's personnel shall have successfully completed the NV Energy Natural Gas Safety Training course and maintain in their possession the certification card providing evidence of training.
 2. The cost of such training shall be the responsibility of the Contractor.
 3. In no instance shall existing gas facilities (valves, etc.) be operated, gas introduced into piping, or purging operations be performed without the continued presence and knowledge of an NV Energy Representative or Inspector.
- I. Contractor's personnel performing work on asbestos or transite pipe, including without limitation cutting, tapping, repairing, handling or removing, must have successfully completed specialized OSHA training in the handling and disposal of asbestos prior to the performance of any such

work, or Contractor shall hire a subcontractor that has successfully completed specialized OSHA training in the handling and disposal of asbestos to perform such work.

6.12 Use of Site

- A. The Contractor shall confine his activities to within the prescribed easements or work area boundaries and shall leave the work areas in a state equal to or better than the conditions that existed before the work began.
- B. During construction, the Contractor shall remove debris as necessary to maintain a safe and obstacle-free construction and traffic area.
- C. The Contractor shall be responsible for:
 - 1. Maintaining a reasonably dust-free work area and to prevent dust from blowing off of the site by keeping the work areas dressed, smoothed, watered and compacted as required. Refer to Article 6.15 “Dust Control” of the General Conditions for specific requirements.
 - 2. Offsite disposal of any excess or unsuitable material at the expense of the Contractor.
 - 3. Notifying all impacted residences or businesses and for maintaining adequate access for all residences/businesses.
 - 4. Trench dewatering and for the legal disposal of groundwater removed from excavations.

6.13 Protection of Existing Vegetation and Improvements

- A. The Contractor shall preserve and protect all structures, equipment, and vegetation (such as trees, shrubs, and grass) on or adjacent to the work site, which are not to be removed and which do not unreasonably interfere with the work required under this contract.
- B. The Contractor shall only remove trees when specifically authorized to do so, and shall avoid damaging vegetation that will remain in place.
 - 1. Trees within the city right-of-way shall not be cut or removed without the permission of the city.
 - 2. If any limbs or branches of trees are broken during contract performance, or by the careless operation of equipment, or by workmen, the Contractor shall trim those limbs or branches with a clean cut and paint the cut with a tree-pruning compound.
- C. The Contractor shall protect from damage all existing improvements and utilities at or near the work site, and on adjacent property of a third party, the locations of which should be known or anticipated by the Contractor.
 - 1. The Contractor shall repair any damage to those facilities, including those that are the property of a third party, resulting from failure to comply with the requirements of this contract or failure to exercise reasonable care in performing the work.
 - 2. If the Contractor fails or refuses to repair the damage promptly, TMWA may have the necessary work performed and charge the cost to the Contractor.

6.14 Construction Site Stormwater Control

- A. General.
 - 1. The Contractor shall comply with all federal, state, and local laws and all permit conditions governing discharge of stormwater from the Project site(s).
 - 2. The Contractor may be required by other permitting agencies to provide information on land disturbance as part of the permit review process. It is the Contractor’s responsibility to provide all information requested in a timely manner so that there is no delay in permit

issuance. No time extension will be granted or addition compensation paid because of the Contractor's failure to make timely submittals to permitting agencies.

3. The Contractor shall include the costs associated with complying with these requirements in the price bid for the Project. If there is no bid item for erosion control or construction site stormwater control, the costs for temporary and permanent BMP's shall be considered as included in the other items of work listed on the Bid Schedule.

B. Construction Site Stormwater Permit

1. When required by the Supplementary Conditions, the Contractor shall prepare a project specific Stormwater Pollution Prevention Plan (SWPPP) and submit a Notice of Intent (NOI) to NDEP.
 - i. Copies of the SWPPP and NOI shall be furnished to the Project Representative for review and approval.
 - ii. SWPPP's shall be prepared using the Regional Program SWPPP template per Appendix C of the BMP Handbook. This template is available in Word format at www.TMstormwater.com.
2. Per Article 6.06 "Permits" of the General Conditions, the Contractor is responsible for paying the filing fee when a NOI is required.

C. Minimum Requirements for Construction Site Stormwater Control

1. Regardless of whether preparing a SWPPP and filing a NOI is required or not, BMP's shall be implemented and maintained throughout the entire time of Project construction, 24 hours per day, 7 days per week until the Work is complete.
2. Select and manage BMP's to meet the twelve Performance Standards listed in Section 3.3 of the BMP Handbook.
3. Temporary and permanent BMP's shall address all five categories listed in the BMP Handbook: Planning, Runoff Control, Erosion and Sediment Control, Drainageway Protection, and General Site and Materials Management.
4. Install and maintain temporary BMP's during construction as required by the approved SWPPP, the BMP Handbook, the BMP Field Guide, and permit conditions as applicable.
5. Implement permanent BMP's at completion of construction.
6. Establish temporary or permanent BMP's on disturbed areas as soon as practicable after construction activity in that portion of the site has temporarily or permanently ceased.
7. Additional requirements for erosion control, construction site stormwater control, and surface restoration may be specified in the Supplementary Conditions or Technical Specifications.

D. Temporary BMP's

1. BMP's in accordance with the BMP Handbook, permit conditions, and approved SWPPP as applicable shall be in place prior to beginning soil disturbing activities and shall be maintained in an operational condition at all times until permanent measures are in place.
2. BMP's shall be adjusted as required by changing site conditions or changes in the Contractor's means and methods to prevent discharge of sediment from the site. The SWPPP (if one is required) shall be revised as necessary to document all changes in BMP's.
3. Inspect BMP's at the following intervals or more frequently if found necessary by site conditions or required by permit conditions.
 - i. Weekly.
 - ii. Prior to forecast rain events to ensure that BMP's are in place and functioning properly.
 - iii. Within 24 hours of a rain event that creates runoff at the site.
 - iv. Within 24 hours of a storm event of 0.5-inch or more.

4. Repair, restore, or reconstruct BMP's as indicated by the inspection. Maintain a written record of inspections and repairs. Include photographs at Contractor's option or if requested by the Project Representative.

E. Permanent BMP's

1. Unless otherwise shown on the Drawings or specified in the Technical Specifications, the minimum permanent BMP's for disturbed soils shall be soil roughening (EC-2) followed by revegetation (EC-8) and mulching (EC-3).
 - i. Seed mix shall be a blend of native grasses and plants and shall not contain invasive species. The mix shall be the Generic Revegetation Seed Mix for Upland Sites in northern Nevada as specified in Appendix A of the BMP Field Guide and as modified to suit site conditions.
 - ii. Seed mix shall be applied at a rate of 30.35 pounds per acre of pure live seed or at a rate recommended by the seed Supplier, whichever is greater.
2. The site will be considered to be permanently stabilized when either:
 - i. A uniform perennial vegetative cover with a density of 70 percent of the native background vegetative cover is established on all unpaved areas and areas not covered by permanent structures, or
 - ii. Equivalent permanent stabilization measures as shown on the Drawings or specified in the Technical Specifications are established. If no equivalent measures are shown or specified, then vegetative cover as specified above is required.

F. Notice of Termination

1. If a NOI was filed with NDEP, the Contractor shall file a Notice of Termination with NDEP when:
 - i. All soil disturbing activities are complete.
 - ii. The site is permanently stabilized as specified above.
 - iii. Temporary BMP's have been removed.
2. A copy of the Notice of Termination shall be filed with the Project Representative as specified in the Supplementary Conditions.

6.15 Dust Control

A. General

1. The Contractor shall comply with all federal, state, and local laws and all permit conditions governing control of dust from the Project site(s).
2. The Contractor shall include the costs associated with complying with these requirements in the price bid for the Project. If there is no bid item for dust control, the costs for dust control shall be considered as included in the other items of work listed on the Bid Schedule.

B. Dust Control Permit and Requirements

1. The Supplementary Conditions will specify whether a dust control permit is required for the Project.
2. If a permit is not required, the Contractor shall control dust from construction activities 24 hours per day, 7 days per week so as not to create a nuisance or safety hazard and shall comply with all Washoe County ordinances governing control of dust from the Project.
3. If a permit is required, TMWA will obtain the permit from the Washoe County Health Department, pay the fee, and furnish a copy of the final permit to the Contractor. The Contractor shall control dust from construction activities 24 hours per day, 7 days per week so as not to create a nuisance or safety hazard, shall comply with all permit conditions, and is responsible for the following:

- i. Furnishing to the Project Representative the name, 24 hour phone number, and email address of two employees for listing on the permit application as persons to be contacted during non-working hours in case of dust problems.
 - ii. Preparation of the dust control plan and furnishing to the Project Representative all other information required for TMWA to submit the dust control permit application.
 - iii. Providing the dust permit informational signage. The Contractor's 24 hour phone number shall be listed on the sign. No TMWA phone numbers shall be shown on the sign unless specifically required by the permit conditions.
 - iv. Ensuring that the dust control permit is available on site at all times for inspection by a Washoe County air quality specialist.
 - v. Maintaining the Washoe County Dust Control Log on a daily basis if required by the permit conditions.
 - vi. If the area disturbed by the Contractor's operations exceeds the area on which the permit fee was calculated and the Health Department determines that an additional fee is required, the Contractor is responsible for payment.
4. At completion of construction, all disturbed areas shall be stabilized as specified in the Contract Documents. If no stabilization method is specified, a chemical sealant or other method approved by the Washoe County Health Department shall be used to stabilize the disturbed areas.
 5. The Contractor shall be responsible for payment of any fines assessed by Washoe County for violation of the permit. TMWA will deduct the amounts from monies due the Contractor unless they are paid directly to the County by the Contractor.

6.16 Quality Control

- A. The Contractor shall maintain an adequate quality control system and perform such inspections as will ensure that the work performed under the Contract Documents conforms to the Contract Documents requirements.
- B. The Contractor shall at Contractor's expense provide all testing required to demonstrate that the materials being furnished meet the requirements of the Contract Documents. Copies of test results and material certificates shall be furnished to the Project Representative upon request or when required by the Technical Specifications.
- C. The Contractor shall inspect equipment and materials upon arrival at the job site and again immediately prior to installation or use. Any item found to be damaged, defective, or otherwise not meeting the requirements of the Contract Documents shall be immediately removed from the site and replaced with items meeting the Project requirements.
- D. The Contractor shall maintain complete inspection records and make them available to TMWA upon request.

6.17 Record Drawings

- A. The Contractor shall maintain, in a safe place at the job site, one record copy of the Drawings in good order and annotated to show all changes (vertical or horizontal alignments included) made during construction and all existing facilities exposed during construction.
- B. These record drawings shall be kept current and made available to the Engineer and Project Representative for reference upon request.
- C. Within ten calendar days following completion of the Work, these record drawings shall be delivered to TMWA. The Notice of Completion will not be issued and final payment, including any retention of progress payments made to the Contractor, will not be released until TMWA has received all record drawings.

6.18 Warranty

- A. In addition to any other warranties in the Contract Documents, notwithstanding latent defects, gross mistakes or fraud, Contractor warrants that that all materials and equipment provided are new and free from defects and that work performed under this contract conforms to the Contract Documents requirements and is free of any defect in equipment, material, or design furnished, including workmanship performed by the Contractor or any Subcontractor or Supplier at any tier.
- B. With respect to all warranties, express or implied, from Subcontractors, manufacturers, or Suppliers for work performed and materials furnished under this contract, the Contractor shall obtain all warranties that would be given in normal business practice; require all warranties to be executed, in writing, for the benefit of TMWA; and enforce all warranties for the benefit of TMWA. In the event the Contractor's warranty under this clause has expired, TMWA may bring suit to enforce a Subcontractor's, manufacturer's, or Supplier's warranty.
- C. This warranty shall continue for one year from the date of the Project Representative's determination that the project is complete.
- D. TMWA shall notify the Contractor, in writing, within a reasonable time after discovery of any failure, defect or damage.
 - 1. If the Contractor fails to remedy any failure, defect, or damage within a reasonable time after receipt of notice, TMWA shall have the right to replace, repair, or otherwise remedy the failure, defect, or damage at the Contractor's expense.
 - 2. The Contractor shall remedy, at the Contractor's expense, any failure to conform, or any defect, or any damage to TMWA property, when the damage arises out of the Contractor's failure to conform to contract requirements; or any defect of equipment, material, workmanship, or design furnished.
 - 3. The Contractor shall not be liable for the repair of any defects of material or design directly furnished by TMWA.
- E. The Contractor shall restore any work damaged in fulfilling the terms and conditions of this clause. The Contractor's warranty with respect to work repaired or replaced will run for one year from date of repair or replacement.
- F. This warranty shall not limit TMWA's rights under Article 10.02 "Inspection and Testing by TMWA" of the General Conditions with respect to latent defects, gross mistakes or fraud.

6.19 Right to Audit

- A. The Contractor shall keep full and detailed accounts and records and exercise such controls as necessary for proper financial management under this contract.
 - 1. The accounting and control systems utilized by Contractor shall be acceptable to TMWA.
 - 2. TMWA shall be afforded access to the Contractor's records, books, correspondence, instructions, drawings, receipts, subcontracts, purchase orders, vouchers, memoranda and all other data relating to this contract.
 - 3. The Contractor shall preserve; and TMWA shall be entitled to audit, all such records and documents for a period of three years after final payment (or for such longer period as may be required by law).
- B. In conducting its audit of Contractor's records and documents, TMWA shall be afforded access to Contractor's facilities; allowed to interview current or former employees to discuss matters pertinent to the performance of the Contract Documents; shall be provided access to all records and documents; and shall be provided with adequate and appropriate work space to conduct the audit.

- C. If an audit inspection or examination conducted in accordance with this Article discloses overpricing or overcharges of any nature by Contractor to TMWA in excess of one-half of one percent of the total contract billings, the Contractor shall reimburse TMWA for the reasonable actual cost of TMWA's audit, in addition to repayment or credit for the overcharges. Any adjustments and/or payments, which must be made as a result of any, such audit or inspection of the Contractor's invoices and/or records, shall be made within a reasonable amount of time (not to exceed 90 days) from presentation of TMWA's findings to Contractor.

Article 7 Payment and Retention

7.01 Payment for Mobilization

- A. Obviously unbalanced Bids may be considered unresponsive and may result in such Bid being rejected by TMWA as not in conformance with the Contract Documents.
- B. The Contractor's mobilization bid item cost shall include only those items necessary and preliminary to performance of the work. Such costs may include, but are not necessarily limited to:
 - 1. The cost of moving labor, material and equipment to the site of the work.
 - 2. The cost of project specific insurance premiums and bond premiums.
 - 3. Project startup costs such as field offices, sanitary facilities, utilities, etc.
 - 4. The cost of acquiring project permits and permit fees if paid by the Contractor.
- C. The Contractor shall, upon request by TMWA, provide a detailed breakdown of anticipated or estimated mobilization costs.
- D. Payment for mobilization in any one calendar month is limited to the amount bid in the Bid Schedule, 10 percent of the contract amount not including mobilization, or the pro rata amount of the mobilization actually completed in that month whichever amount is less.
- E. Mobilization costs shall not be invoiced to TMWA until the first progress payment application is submitted for the project.

7.02 Progress Payments

- A. Per the provisions of NRS 338, Sections 400 through 645, Contractor shall submit application for progress payment once per month, directly to TMWA's Project Representative. Project Representative will review and if correct, approve the application for payment.
- B. Should Project Representative dispute any portion of Contractor's progress payment application, Project Representative shall provide Contractor with written explanation of the disputed amounts within five days of receipt of progress payment application.
 - 1. The Contractor shall then revise and resubmit the invoice, or follow formal dispute resolution procedures.
 - 2. To insure timely payment, the Contractor is encouraged to review preliminary progress payment applications with Project Representative prior to officially submitting the monthly invoice.
- C. Undisputed and approved invoice amounts will be paid to Contractor within 30 days of the date that TMWA receives the approved invoice.
- D. Per the provisions of NRS 338.515 paragraph 2, the Contractor's progress payment application may include the invoice cost of materials that have been purchased and stockpiled for use on the project but not yet incorporated into the work if in the opinion of Project Representative, the materials are suitably stored, protected and secured.

1. Materials shall be stockpiled at the job site or at a location under the control of the Contractor that is within 30 miles of the job site.
 2. Materials shall be separately stockpiled and tagged or marked in such a manner that they are easily identified as materials for the Contract Documents. Materials shall not be moved, except for transportation to the job site, without the permission of the Project Representative.
 3. Materials shall be available for inspection by the Project Representative at all times during normal working hours.
 4. Materials shall be utilized on this contract only.
- E. TMWA may refuse to make payment of the full amount of the progress payment application because claims have been made against TMWA on account of Contractor's performance or furnishing of the work, or there are other items entitling TMWA to a set-off against the amount recommended, but TMWA must give Contractor immediate written notice stating the reasons for such action.

7.03 Extra Work – Request for Approval

- A. When Contractor reasonably believes the work or materials required by TMWA is beyond the original scope of Work, the Contractor shall notify the Project Representative in writing that it believes such work is "Extra Work". TMWA will promptly determine whether such work constitutes "Extra Work" or Work within the original scope of the Contract Documents. TMWA shall not be liable for delay claims by the Contractor prior to providing written determination of Contractor's Extra Work claim.
- B. Any alleged extra work performed by the Contractor without prior written authorization of TMWA is done at the sole risk of the Contractor. Contractor shall have no right or claim to additional compensation, nor may Contractor seek any such compensation in any forum, unless Contractor provides notice of the Extra Work demand pursuant to Section 7.03(A) prior to commencing such work. The requirements of this Section 7.03 can only be waived in writing by TMWA.
- C. TMWA reserves the right to request a lump sum cost proposal from the Contractor for the performance of extra work. If a lump sum cost proposal is requested, the Contractor shall also obtain competitive lump sum quotations from Subcontractors for extra work.
- D. If TMWA determines that the work or materials required are beyond the original scope of the Work and constitute "Extra Work", and TMWA authorizes Contractor in writing to perform such Extra Work, the provisions in Section 7.04 shall apply.

7.04 Extra Work – Payment for Time and Material Work

- A. The provisions of this Section 7.04 shall apply to Extra Work authorized in writing by TMWA.
- B. When the underlying Work is performed under a time and material basis, TMWA may request the Contractor to submit a Work Plan prepared specifically for the authorized Extra Work item to TMWA for approval prior to TMWA authorizing the extra work to begin.
1. The Work Plan shall include at a minimum, the classification, prevailing hourly wage rate (including fringe benefits), and actual hourly pay rate for each person to be utilized in performing the work; the number of days per week and the number of hours per day that work will be performed; and the number, type and cost (specifying equipment rates) of each piece of equipment to be utilized.
 2. Whether or not a written Work Plan was requested, the Contractor and TMWA's Project Representative shall pre-determine and agree upon the above mentioned Work Plan components prior to start of the extra work.

- C. The Contractor shall complete and sign a daily labor and equipment reporting form (Daily Extra Work Report) at the end of each day for extra work performed under this contract.
1. The Daily Extra Work Report shall clearly indicate the date, name of the project, detailed scope of extra work performed that day, hours worked by each employee, the employee's labor classification, each piece of equipment with hours utilized, and materials delivered to the job site which are suitably stored or incorporated into the extra work.
 - i. Invoices for materials shall be furnished to the Project Representative when available.
 - ii. Equipment shall be identified by manufacturer's name, model number, and the five letter equipment class code from the Rental Rate book (see paragraph 7.04J below).
 2. The Project Representative will review and approve (when correct) the form and return a copy of the form to the Contractor by the following workday.
 3. No payment will be made for extra work not reported on an approved Daily Extra Work Report and supported by the appropriate material invoices.
- D. A full time working foreman shall be present at the job site to supervise extra work at all times.
- E. The following rules apply to billing employee time for authorized extra work:
1. Superintendent and general foreman time may be direct billed at the applicable foreman rate.
 2. Time for documented safety meetings is considered compensable time for extra work performed under this contract.
 3. Job site reporting shall be utilized for extra work performed under this contract. Travel time to and from the job site will not be considered compensable time.
 4. The Contractor's billable time begins and ends at the job site with the starting and stoppage of work.
 5. Time preparing daily extra work reports, timesheets and invoices will not be considered compensable time.
 6. Overtime (time in excess of eight hours in one day or in excess of 40 hours in one week) shall be approved in writing by the Project Representative prior to the start of overtime work under time and material conditions.
- F. The following rules apply to billing and use of equipment and tools for authorized extra work:
1. TMWA will not compensate the Contractor for nonproductive time resulting from not having the required tools or equipment in his possession at the job site or the unavailability of tools or equipment resulting from breakdown, maintenance or repairs. The Project Representative shall be the sole judge as to whether the Contractor is, can be, or was productive when working without adequate tools or equipment due to breakdown or unavailability.
 2. Individual pieces of equipment or tools having a replacement value of \$500 or less, whether or not consumed by use, will be considered to be small tools and no separate payment will be made for their use.
- G. The Contractor will be paid the total cost for labor, materials, equipment, and miscellaneous items used to perform authorized extra work that is paid for on a time and materials basis. The total cost will be calculated as the sum of the following five items:
1. The direct cost of labor, materials, and equipment determined as specified in paragraphs H, I and J below.
 2. To the total of the direct costs, the following markups shall be applied:
 - i. A labor markup of 40 percent to the direct cost of labor.
 - ii. A materials markup of 10 percent to the direct cost of materials.
 - iii. An equipment markup of 15 percent to the direct cost of equipment.

3. The above markups shall constitute full compensation for all overhead costs and profit and any additional items of expense not specifically listed as labor, materials, and equipment costs in paragraphs H, I and J below. Additionally, the markup specified in item 2i above includes full compensation for all payments required by State and Federal laws, such as Social Security, Medicare, unemployment insurance, and similar items.
 4. When extra work is performed in whole or in part by Subcontractors at any tier, an additional markup shall be applied to cover the Contractor's expenses associated with supervising and coordinating subcontract work. The markup for subcontractor coordination shall be 5 percent applied to the total of the direct cost for labor, materials, and equipment for extra work performed by Subcontractors that is paid for on a time and materials basis. In calculating the markup for subcontractor coordination:
 - i. The subcontractor coordination markup is only applied to Subcontractor direct costs. Direct costs of the Contractor and Owner-operators are excluded from this calculation.
 - ii. The markups specified in item 2 above are not applied to the Subcontractor direct costs before applying the 5 percent markup.
 - iii. The subcontractor coordination markup only applies to the total of all extra work performed by Subcontractors. It does not apply between the various Subcontractor tiers.
 5. The cost of owner-operated equipment determined as specified in paragraph K below.
 6. The cost of miscellaneous items including specialized work, professional services, permits, and fees determined as specified in paragraph H below. The markups specified above do not apply to miscellaneous items.
 7. Table 7.04G is included to further clarify how TMWA will calculate the payment for time and material work. The shaded areas of the table are where the descriptive information and amounts based on the hours reported on the Daily Extra Work Reports are entered.
 - i. The formulas shown on the right hand side of the form show how the various markups, sub-totals, and totals are calculated.
 - ii. The amounts shown in the table are for illustrative purposes only.
- H. The direct cost of labor for workers (including working foremen) for authorized extra work, whether the employer is the Contractor or a Subcontractor at any tier, shall be the sum of the following two items:
1. The actual wages paid to or on behalf of the employee. The actual wages are defined as the sum of the hourly rate of pay plus the hourly fringe benefit contributions shown on the certified payroll data submitted by the Contractor to TMWA.
 - i. For Projects where prevailing wage rates do not apply, actual wages will be the sum of the hourly rate of pay plus any hourly fringe benefit contributions shown on the employee's pay check advice.
 - ii. Actual wages do not include any payments made on behalf of the employee for which the Contractor is compensated by the markup specified in paragraph G2i above.
 2. The actual subsistence and travel allowance paid to workers up to a maximum amount of \$125.00 per worker per day. Subsistence and travel allowance will be paid only if the extra work being paid for on a time and material basis results in an extension of the Contract Time.
- I. The direct cost of materials for authorized extra work whether purchased by the Contractor or a Subcontractor at any tier shall be the actual amount paid as evidenced by invoices submitted to the Project Representative. Only materials that are incorporated into the Work will be paid for.
- In addition to the direct cost of materials, the Contractor will be paid the direct cost of labor and equipment required to unload job-site delivered materials or to obtain and deliver Contractor furnished materials which are not delivered to the job site by the Supplier, unless this is a result of a scheduling or procurement error on the part of the Contractor.

1. Direct labor costs for unloading job site delivered materials shall be determined per paragraph H1 above (no payment for subsistence and travel will be made).
2. Direct equipment costs for unloading job site delivered materials shall be determined per paragraph J below.

	A	B	C	D	E	F	G	H	I	J	K	L	M	N
1	=	Input cells												
2														
3														
4														
5														
6														
7														
8														
9														
10														
11														
12														
13														
14														
15														
16														
17														
18														
19														
20														
21														
22														
23														
24														
25														
26														
27														
28														
29														
30														
31														
32														
33														
34														
35														
36														
37														
38														
39														
40														
41														
42														
43														
44														
45														
46														
47														
48														
49														
50														
51														

EXAMPLE

Table 7.04C¹
Time and Materials Summary Calculation Sheet

Date	
Project Name	
Project Number	
Extra work description	
Change Order number	
Is this a prevailing wage project? (Y or N)	Y

	Contractor	Subcontractor 1	Subcontractor 2	Owner-operators	Totals
Labor					
Actual wages:	4,500.00	2,000.00	1,000.00	300.00	7,800.00
Travel and subsistence:	125.00	-	-	125.00	250.00
				Sub-total Direct Labor:	8,050.00
				40% Markup on direct labor:	3,220.00
				Total Labor:	\$ 11,270.00

Materials²					
Direct cost per invoices:	2,500.00	400.00	100.00	-	3,000.00
				10% markup on direct cost of materials:	300.00
				Total Materials:	\$ 3,300.00

Equipment					
Direct cost per rental rates:	400.00	-	750.00	145.00	1,295.00
				15% markup on equipment:	194.25
				Total Equipment:	\$ 1,489.25

Calculation of 5% Subcontractor Coordination Markup					
Direct cost totals without markups (Subcontractor work only):	2,400.00	1,850.00	-	-	4,250.00
				5% markup for Subcontractor coordination:	212.50

Miscellaneous Items					
Specialized Work per invoices:	2,000.00	-	-	-	2,000.00
Professional Services per invoices:	250.00	-	-	-	250.00
Owner-operated equipment per invoices (non-prevailing wage projects only):	-	-	-	-	-
Permits and fees:	500.00	-	-	10% markup on above three items:	225.00
				200.00	700.00
				Total Miscellaneous:	3,175.00
				Total Cost:	\$ 19,446.75

Notes: 1. Add or subtract columns for additional subcontractors and Owner-operators as required.
2. Direct costs for unloading materials shall be added to the Labor and Equipment sections as appropriate.

3. Markups for direct labor and equipment costs for unloading job site delivered materials shall be applied as specified in paragraphs G2i and G2iii above. No other markups shall be applied to these items for unloading job site delivered materials.

A foreman or a designated materials coordinator shall be responsible for insuring that materials are procured and delivered to the site in a timely manner. The Contractor will not be compensated for nonproductive time nor will an extension of time be granted due to delays in delivery of material or equipment when these items are Contractor furnished.

- J. The direct cost of equipment used to perform authorized extra work whether used by the Contractor or a Subcontractor at any tier shall be the hourly rental rates listed in the CalTrans publication "Labor Surcharge And Equipment Rental Rates" (Rental Rate book) that is in effect on the date on which the extra work is done. The rates apply regardless of ownership and any rental or other agreement. The Rental Rate book is available from CalTrans at www.dot.ca.gov/hq/construc/.
 1. Rental rates listed in the Rental Rate book are straight time rates that apply when the equipment is used 8 hours or less per day as shown on the Daily Extra Work Report.
 - i. Overtime hours occur when the equipment has worked on extra work more than eight hours per day or more than the daily equivalent of forty hours per week for special work schedules (e.g. 4/10 or 9/80).
 - ii. When work extends into overtime conditions as shown on the Daily Extra Work Report, the Overtime Factors listed in the Rental Rate book shall be used to determine the overtime rate. The Delay Factors and Labor Surcharge rates listed in the Rental Rate book do not apply to TMWA work.
 - iii. The overtime rate is the product of the straight time rate and the Overtime Factor. The overtime rate shall be applied per the instructions in the Rental Rate book for "Overtime and Multiple Shifts."
 2. For equipment not listed in the Rental Rate book, a suitable rental rate shall be established, before using such equipment on extra work, by agreement between the Project Representative and the Contractor. In establishing such rate, the Contractor shall submit cost data or other evidence to support the proposed rate if requested by the Project Representative. Submitted rates shall be consistent with similar size and type of equipment listed in the Rental Rate book. In the event that agreement on a rate cannot be reached, the rate proposed by the Project Representative will be used.
 3. The rental rates include the cost of fuel, oil, lubrication, supplies, small tools, necessary attachments, repairs and maintenance of any kind, depreciation, storage, insurance, all incidentals, and any labor required to provide these items.
 4. Operators of rental equipment will be paid as specified in paragraph H above.
 5. Rental time will not be allowed while equipment is inoperative due to breakdowns.
 6. The Contractor will be paid rental time for only those hours that the equipment is actually utilized in performing the extra work. Idle time for equipment located at the job site, but not being used in the work, is not billable time.
 7. When the extra work requires use of equipment that is different from the equipment on the job site being used for Contract work, the following shall apply:
 - i. The Project Representative shall approve the necessity for the use of the particular equipment on the extra work.
 - ii. The Contractor shall obtain quotes for renting the equipment from local sources. The rental rate paid for locally rented equipment will be the actual rate paid by the Contractor or the rate listed in the Rental Rate book, whichever is less.
 - iii. Rental time will be paid for the time required to move the required equipment to the location of the extra work and return it to its original location, except that moving time

will not be paid for if the equipment is also used on regular contract work while on the job site. The original location of the equipment to be moved shall be agreed to by the Project Representative in advance of movement.

- K. When owner-operated equipment is used to perform authorized extra work that is paid for on a time and materials basis, the Contractor will be paid for the equipment and operator as follows. (items 1, 2, and 3 apply to Projects subject to payment of prevailing wage rates):
1. Payment for equipment will be made in conformance with paragraph J above.
 2. Payment for the cost of labor and subsistence or travel allowance will be made at the rates paid by the Contractor to other workers operating similar equipment already on the project or, in the absence of other workers operating similar equipment, at the rates for that labor established by collective bargaining agreements for the type of workers whether or not the owner-operator is actually covered by an agreement.
 3. The markups on labor and equipment specified in paragraphs G2i and G2iii above shall then be added to determine the total compensation to the Contractor for owner-operated equipment.
 4. For Projects where prevailing wage rates do not apply, payment for owner-operated equipment shall be the actual cost as evidenced by invoices submitted to the Project Representative. A 10 percent markup shall be added to the invoice amount for overhead and profit as full compensation for owner-operated equipment. The markups specified in paragraphs G2i and G2iii do not apply to this case.
- L. The cost of miscellaneous items for authorized extra work shall be determined as follows:
1. Specialized work is work for which the Contractor is not experienced in or properly equipped for and is typically done by a specialist that is proficient in the type of work to be performed. Payment for specialized work shall be the actual cost as evidenced by invoices submitted to the Project Representative. A 10 percent markup shall be added to the invoice amount for overhead and profit as full compensation for specialized work.
 2. The cost of professional services, such as engineering and material testing, associated with the extra work and directly paid by the Contractor will be the actual cost as evidenced by invoices submitted to the Project Representative. A 10 percent markup shall be added to the invoice amount for overhead and profit as full compensation for professional services.
 3. Permits and fees required by regulatory agencies that are paid by the Contractor will be reimbursed at actual cost as evidenced by invoices submitted to the Project Representative. No markup is allowed on these items.

7.05 Unit Cost Adjusting Bid Items

- A. If unit cost adjusting bid items are included in the Bid Schedule, they will be used to compensate the Contractor for the common situations that arise during construction without the need for a Change Order. The range of applicability of items normally used are as follows:
1. The item for reduced or increased trench depth is intended to allow profile adjustments within a range of ± 3 feet.
 2. The rock excavation adjusting items are intended to allow for isolated boulders or minor pockets of bedrock. The range of applicability of these items is from 0 to 100 cubic yards.
 3. The applicable range for other adjusting items will be listed in the Technical Specifications.
- B. When the adjustments or quantities of the adjusting bid items is outside of the specified applicable range the procedures of Article 3.05 "Changes to the Contract" and Article 4.03 "Differing Conditions" of the General Conditions will apply.

7.06 Retention and Final Payment

- A. Retention will be withheld as follows:
1. Except as otherwise permitted in NRS 338.525, until the Work is 50 percent complete, TMWA will withhold as retainage from all progress payments an amount equal to five percent (5%) of any amount invoiced or otherwise due for payment (including approved Change Orders) from each progress payment.
 2. Except as otherwise provided in NRS 338.525, after the Work is 50 percent complete and in the opinion of the Project Representative satisfactory progress is being made toward completion of the Work, TMWA shall continue to withhold retainage from progress payments as follows:
 - i. If TMWA does not withhold any amount pursuant to NRS 338.525:
 - a. TMWA will withhold from each subsequent progress payment 2.5 percent of the amount invoiced or otherwise due for payment from each subsequent progress payment; and
 - b. Before withholding any amounts under 7.06(A)(2)(i)(a), TMWA will pay to Contractor fifty percent (50%) of any retainage being held pursuant to 7.06 (A)(1) in accordance with Nevada law.
 - ii. If TMWA withholds any amount pursuant to NRS 338.525, TMWA will withhold from each subsequent progress payment five percent (5%) of the amount invoiced or otherwise due for payment from each subsequent progress payment and will continue to hold amounts retained under 7.06(A)(1) in accordance with Nevada law.
 3. If in the opinion of the Project Representative satisfactory progress toward completion of the Work is not being made, retention will remain as specified in 7.06(A)(1) until progress is judged to be satisfactory. At that time the retention policy of 7.06(A)(2) will take effect.
 4. Notwithstanding the foregoing, TMWA reserves the right to withhold additional amounts from progress payments or final payments in accordance with NRS 338.515(7) and NRS 338.525.
- B. Interest will be paid to the Contractor quarterly on retainage per the provisions of NRS 338.515.
- C. Retention withheld by TMWA will be paid to the Contractor within 30 days after TMWA issues the Notice of Completion, the Labor Commissioner has been notified that the Work is complete, no prevailing wage complaints or investigations remain pending, and after receipt of all other items required by the Contract Documents, in accordance with NRS 338.520. Refer to the Supplementary Conditions for a detailed list of items that must be submitted before TMWA will consider the Project to be complete.
- D. The making and acceptance of final payment will constitute a waiver of all claims by Contractor against TMWA other than those previously made in writing and still unsettled.

Article 8 Time Extensions and Delays

8.01 Time Extensions

- A. Notwithstanding any other provisions of this contract, it is mutually understood that the time extensions for changes in the work will depend upon extent, if any, by which the changes cause delay in the completion of the various elements of construction.
- B. A Change Order granting the time extension may provide that the contract completion date will be extended only for those specific elements so delayed. The remaining contract completion dates for all other portions of the work will not be altered, and may further provide for an equitable readjustment of liquidated damages (if applicable) under the new completion schedule.

8.02 Delays

- A. Upon mobilization to the site, the Contractor shall maintain an adequate labor and equipment workforce and diligently perform the Work to the satisfaction of the Project Representative.
 - 1. The Contractor shall include adequate costs in his Bid prices to provide sufficient levels of labor and equipment (including overtime, if required) to insure that the required completion date is met.
 - 2. Weather delay days will not extend the completion date unless both Contractor and Project Representative agree to declare a weather day.
- B. Should the timely performance of this contract be jeopardized by the non-availability of TMWA provided personnel, data, or equipment, the Contractor shall immediately notify the Project Representative in writing of the facts and circumstances, which are contributing to such delay. Upon receipt of this notification, TMWA will advise the Contractor in writing of the action that will be taken to remedy the situation.
- C. The Contractor shall advise TMWA in writing of an impending failure to meet established milestones or completion dates.
 - 1. Such notification shall include a written description of how the Contractor plans to correct the situation and comply with the project schedule.
 - 2. Notice shall be provided as soon as the Contractor is aware of the situation; however, such notice shall not relieve the Contractor from any existing obligations regarding performance.

8.03 Excusable Delays

- A. Except for defaults of Subcontractors at any tier, the Contractor shall not be in default because of any failure to perform this contract under its terms if the failure arises from causes beyond the control and without the fault or negligence of the Contractor. Examples of these are:
 - 1. Acts of God, terrorism, or of public enemy.
 - 2. Acts of the government.
 - 3. Fires.
 - 4. Floods.
 - 5. Epidemics.
 - 6. Quarantine restrictions.
 - 7. Strikes.
 - 8. Freight embargoes.
 - 9. Unusually severe weather.
- B. In each instance, failure to perform must be beyond the control and without fault or negligence of the Contractor. "Default" includes failure to make progress in the work so as to endanger performance.
- C. If the failure to perform is caused by the failure of a Subcontractor at any tier to perform or make progress, and if the cause of the failure was beyond the control of both the Contractor and Subcontractor, and without the fault or negligence of either, the Contractor shall not be deemed to be in default, unless:
 - 1. The subcontracted supplies or services were obtainable from other sources;
 - 2. TMWA ordered the contractor in writing to purchase these supplies or services from a specific source; and
 - 3. The Contractor failed to comply reasonably with this order.

- D. Upon request of the Contractor, TMWA shall ascertain the facts and extent of the failure. If TMWA determines that the failure to perform results from one or more of the causes above, the completion time shall be revised, subject to the rights of TMWA under the termination clauses of this contract.

Article 9 Suspension and Termination of Work

9.01 Suspension of Work

- A. TMWA may at any time, by written or electronic notice to the Contractor, suspend further performance of work by the Contractor.
 - 1. The notice of suspension shall specify the date of suspension and the estimated duration of the suspension.
 - 2. Upon receiving any such notice of suspension, the Contractor shall promptly suspend further performance of the Work to the extent specified.
- B. TMWA may at any time withdraw the suspension, in whole or in part, by written or electronic notice to the Contractor specifying the effective date and scope of withdrawal. Upon receipt of the withdrawal notice, the Contractor shall resume diligent performance of the work for which the suspension is withdrawn on the specified effective date of withdrawal.
- C. If the Contractor believes that any such suspension or withdrawal of suspension justifies a modification in Contract Sum or delivery, the Contractor shall present a written claim to the Project Representative.
 - 1. Claims shall be submitted no later than 30-days from the action precipitating the claim.
 - 2. Claims presented after 30-days or after final payment of the contract will not be considered valid by TMWA.

9.02 Termination for Convenience

- A. TMWA shall have the right at any time to terminate further performance of this contract, in whole or in part, for any reason. Such termination shall be effected by written notice from the Project Representative to the Contractor, specifying the extent and effective date of the termination.
- B. On the effective date of the termination, the Contractor shall terminate all work and take all reasonable actions to mitigate expenses.
- C. The Contractor shall submit a written request for all outstanding labor and material expenses for work performed through the date of termination, and shall provide any substantiating documentation requested by TMWA.
- D. In the event of such termination, TMWA agrees to pay the Contractor within thirty days after receipt of an adequately documented written request.

9.03 Termination for Cause

- A. TMWA, may, without written notice of default to the Contractor, terminate this contract in whole or part if the Contractor violates an OSHA regulation and the Contractor is found to have a repeat or willful safety violation.
 - 1. A repeat violation exists where documentation shows a serious safety violation for a substantially similar violation documented within the last three years.
 - 2. A willful violation exists where evidence shows either an intentional violation or plain indifference to a safety regulation where the hazard has caused, or was likely to cause death or serious physical harm.

- B. TMWA may, by written notice of default to the Contractor, terminate this contract in whole or in part if the Contractor fails to:
 - 1. Meet the delivery schedule specified in this contract.
 - 2. Make progress, so as to endanger performance of this contract.
 - 3. Perform any of the other provisions of this contract.
- C. TMWA's right to terminate this contract as specified above, may be exercised if the Contractor does not cure such failure within seven calendar days (or more if authorized by the Project Representative) after notice, specifying the failure, is sent.
- D. If TMWA issues a cure notice and the Contractor cures the failure, TMWA has the contractual right to terminate this contract without any additional cure notice if the Contractor makes any future failure.
- E. If TMWA terminates this contract in whole or in part, it may acquire, under the terms and in the manner TMWA considers appropriate, services and equipment similar to those terminated, and the Contractor will be liable to TMWA for any reasonable excess costs for those services. However, the Contractor shall continue the work not terminated.
- F. The Contractor shall not be liable for any excess costs if the failure to perform the contract arises from circumstances beyond the control and without the fault or negligence of the Contractor. These circumstances include, such causes as acts of God or of the public enemy, acts of the Government in either its sovereign or contractual capacity, fires, floods, epidemics, quarantine restrictions, strikes, freight embargoes, unusually severe weather.

Article 10 Other Provisions

10.01 Related Work at Site

- A. TMWA may undertake or award other contracts for additional work at or near the site of work under this contract.
- B. The Contractor shall fully cooperate with the other contractors and with TMWA employees and shall carefully adapt scheduling and performing the work under this contract to accommodate the additional work, heeding any direction that may be provided by TMWA.
 - 1. The Contractor shall not commit or permit any act that will interfere with the performance of work by any other contractor or TMWA employees.
 - 2. Additional specific information concerning work by others will be given in the Supplementary Conditions or Technical Specifications.

10.02 Inspection and Testing by TMWA

- A. All work shall be subject to TMWA inspection and testing at all places and at all reasonable times before acceptance, to ensure compliance with the terms of the Contract Documents.
- B. TMWA inspections and tests are for the sole benefit of TMWA and do not:
 - 1. Relieve the Contractor of responsibility for providing adequate quality control measures per Article 6.16 "Quality Control" of the General Conditions.
 - 2. Relieve the Contractor of responsibility for damage or loss of the material before acceptance.
 - 3. Constitute or imply acceptance.
 - 4. Affect the continuing rights of TMWA after acceptance of the completed work.
- C. The presence or absence of a TMWA inspector or Project Representative does not relieve the Contractor from any contract requirement.

- D. The Contractor shall promptly furnish, without additional charge, all facilities, labor, and material reasonably needed for performing such safe and convenient inspections and tests as may be required by TMWA.
- E. The Contractor shall, without charge, replace or correct rejected work found by TMWA not to conform to contract requirements, unless TMWA consents to accept the work with the appropriate adjustment in the Contract Sum.
 - 1. The Contractor shall promptly segregate and remove rejected material from the premises.
 - 2. If the Contractor does not promptly replace or correct rejected work, TMWA may
 - i. By contract or otherwise, replace or correct the work and charge the cost to the Contractor or
 - ii. Terminate for default the Contractor's right to proceed.

10.03 Replacement of Defective Work

- A. If, before acceptance of the entire Work, TMWA decides to examine already completed work by removing it or tearing it out, the Contractor, on request shall comply.
 - 1. If the work is found to be defective or non-conforming in any material respect due to the fault of the Contractor or Subcontractors, the Contractor shall be responsible for the expenses of the examination and the cost of satisfactory reconstruction.
 - 2. If the work is found to meet the requirements of the Contract Documents, TMWA will pay all costs incurred the Contractor in the examination and reconstruction, including, if completion of the Work was thereby delayed, an extension of time.
- B. Unless otherwise specified in the contract, TMWA shall accept, as promptly as practicable after completion and inspection, all work required by the Contract Documents or that portion of the work TMWA determines can be accepted separately. Acceptance shall be final and conclusive except for latent defects, fraud, gross mistakes amounting to fraud, or TMWA's rights under any warranty or guarantee.

10.04 Use and Possession Prior to Completion

- A. TMWA shall have the right to take possession of or use any completed or partially completed part of the work.
- B. Before taking possession of or using any work, TMWA shall furnish a list of items of work remaining to be performed or corrected on those portions of the work that TMWA intends to take possession of or use. However, failure of TMWA to list any item of work shall not relieve the Contractor of responsibility for complying with the terms of the contract.
- C. While TMWA has such possession or use, the Contractor shall be relieved of the responsibility for the loss of or damage to the work resulting from TMWA's possession or use. If prior possession or use by TMWA delays the progress of the work or causes additional expense to the Contractor, an equitable adjustment shall be made.

10.05 Dispute Resolution

- A. Contractor shall carry on the work and adhere to the progress schedule during all disputes or disagreements with TMWA. No work shall be delayed or postponed pending resolution of any disputes or disagreements, except as Contractor and TMWA may otherwise agree in writing.
- B. The Project Representative will be the initial interpreter of the requirements of the Contract Documents and judge of the acceptability of the Work.

- C. Claims, disputes, and other matters relating to the acceptability of the Work or the interpretation of the requirements of the Contract Documents pertaining to the performance and furnishing of the Work and claims in respect of changes in the Contract Sum or Contract Time (except for claims which have been waived by the making or acceptance of final payment) will be referred initially to Project Representative in writing.
1. Written notice of each such claim, dispute, and other matter shall be delivered by the Contractor to Project Representative promptly (but in no event later than 15 days) after occurrence of the event giving rise to the claim or dispute.
 2. Data or other written evidence necessary to support such claim will be submitted to TMWA within 30 days after such occurrence, unless Contractor requests and Project Representative allows, an additional period of time to ascertain more accurate data in support of the claim.
 3. Within 15 days of receiving all information pertaining to a request for a formal decision in accordance with this paragraph, Project Representative will render a written decision.
 4. Failure of Contractor to submit a claim and any supporting data within the aforementioned time frames shall serve as a waiver by Contractor of such claim against TMWA.
- D. If Project Representative's first-step written decision is unacceptable to Contractor, Contractor shall deliver a written demand for direct negotiation to the Project Representative.
1. Said demand shall be delivered within ten days from the date of the first-step written decision, but in no case will such demand for direct negotiation be accepted by TMWA until after Contractor receives the first-step written decision.
 2. If Contractor fails to deliver said written demand for direct negotiation within the ten-day period, the first-step written decision shall be final and binding.
 3. The second-step direct negotiation may include Project Representative and Contractor's Superintendent (or other on-site representative of Contractor directly responsible for the work who initiated the original claim), but will be conducted by representatives of TMWA and Contractor at least one step (in the organizational structure) above those individuals involved in the first step process.
 - i. Direct negotiation shall be conducted in good faith and may require more than one meeting between TMWA and Contractor.
 - ii. Meetings will be conducted within a reasonable time at a time and place agreeable to both parties.
 4. If after a good faith effort to resolve the claim, should either party believe that a satisfactory resolution of the claim is not possible, either party may give notice to the other party demanding mediation of the issue. Said notice to mediate must be delivered prior to the Contractor applying for final payment, and must be delivered to the other party and the American Arbitration Association.
- E. If direct negotiation is unsuccessful, TMWA and Contractor intend to endeavor to resolve claims, disputes and other matters in question between them by negotiation and mediation in accordance with the Construction Industry Mediation Rules of the American Arbitration Association currently in effect, or unless the parties mutually agree otherwise. The parties shall share the mediator's fee and any filing fee equally. The mediation shall be held in Reno, Nevada unless another location is mutually agreed upon within sixty (60) days of the notice to mediate, unless otherwise mutually agreed. Agreements reached in mediation shall be enforceable as settlement agreements in any Court have jurisdiction thereof.
- F. If the dispute is not resolved by mediation, then, at TMWA's sole discretion, any claim, dispute or other matter in question shall be subject to arbitration in accordance with the provisions of NRS 338.150. The arbitration shall be administered by the American Arbitration Association or Nevada Arbitration Association in accordance with their rules in effect at the time of the

arbitration. Any award or determination rendered by the arbitrator may be entered as a judgment in any court having jurisdiction thereof.

- G. If TMWA, in its sole discretion, declines to arbitrate, such claims, disputes and other matters shall be decided by a court located in Washoe County, Nevada having jurisdiction thereof. Notwithstanding any provision contained in this Article or elsewhere in the Contract Documents, TMWA reserves the following rights in connection with claims and disputes between TMWA and Contractor:
1. The right to institute legal action against the Contractor in any court of competent jurisdiction in lieu of demanding arbitration, in which case the dispute or disputes which are the subject of such action shall be decided by such court, and not by arbitration.
 2. The right to obtain from any Court of competent jurisdiction a stay of any arbitration instituted by the Contractor, provided that the application for such stay is made before the appointment of a neutral arbitrator, in which case the dispute or disputes which are the subject of such arbitration shall be decided by such court, and not by arbitration.

Article 11 Miscellaneous Legal Provisions

11.01 Jurisdiction

- A. This contract shall be construed under the laws of the State of Nevada.
- B. The sole venue for any litigation or arbitration or action to enforce the provisions of this contract shall be Washoe County, Nevada.

11.02 Assignment

- A. Neither party shall assign this contract without the written consent of the other party.
- B. No assignment shall relieve either party of its obligations under this contract.

11.03 No Waiver

- A. Except as otherwise provided herein, the failure at any time of either party to enforce any of the provisions of this contract, or to require at any time performance by the other party of any of the provisions hereof, shall in no way be construed to be a waiver of such provisions, nor in any way be construed to affect the validity of this contract or any part hereof, or the right of any party thereafter to enforce each and every such provision.

11.04 Severability and Integration

- A. The invalidity, illegality, or unenforceability of any provision of this contract or the occurrence of any event rendering any portion or provision of this contract void shall in no way affect the validity or enforceability of any other portion or provision of the entire contract.
- B. Any void provision shall be deemed severed from this contract, and the balance of this contract shall be construed and enforced as if this contract did not contain the particular portion or provision held to be void.
 1. TMWA and Contractor further agree to amend this contract to replace any stricken provision with a valid provision that comes as close as possible to the intent of the stricken provision.
 2. The provisions of this clause shall not prevent this entire contract from being void should a provision which is of the essence of this contract be determined void.

- C. This contract represents the entire and integrated agreement between TMWA and the Contractor. It supersedes all prior and contemporaneous communications, representations, and agreements, whether oral or written, relating to the subject matter of this contract.

11.05 Indemnity

- A. To the fullest extent permitted by law, Contractor shall defend, protect, indemnify and hold harmless TMWA, and its employees, agents, successors, and assigns (“Indemnified Parties”,) and each of them, from and against any and all claims, demands, causes of action, damages, costs, expenses, actual legal fees, losses or liabilities, in law or in equity, of every kind and nature whatsoever (“Claims”) arising out of or in connection with Contractor’s operations to be performed under this Agreement for, but not limited to:
 - 1. Personal injuries, including but not limited to bodily injury, emotional injury, sickness or disease, or death to persons.
 - 2. Workers Compensation, and any violation by Contractor of any law or regulation in any way related to the occupational safety and health of employees.
 - 3. Violation of patent, trademark and copyright laws.
 - 4. Damage or loss to real or personal property of anyone, including loss of use thereof.
 - 5. Breach of contract or related matters.
 - 6. Hazardous waste or environmental liability.
 - 7. Citations, fines, taxes, assessments, or related matters from any local, state or federal governmental authority.
 - 8. Claims of employees, agents, and subcontractors of the Contractor.
- B. Indemnified Parties shall notify the Contractor of the Claim within a reasonable period of time after it has received actual notice of the Claim and the Parties shall take all reasonable actions necessary to assist each other in determining the nature and extent of the issues contained in the Claim.
- C. If a proceeding is commenced against the Indemnified Parties which is based upon or arises out of this contract, then the Indemnified Parties shall be entitled to make the Contractor a party to the proceeding for the purpose of enforcing the terms and conditions of this clause.
- D. The Contractor shall pay all reasonable attorney fees and costs that the Indemnified Parties incurs or is subject to as a result of the Claim.
- E. Nothing in this Agreement shall be construed to waive TMWA’s right to assert available NRS Chapter 41 liability limitation against any claim.
- F. The obligations contained herein shall survive any termination of this Agreement.

END OF GENERAL CONDITIONS

Section 00800
SUPPLEMENTARY CONDITIONS

ARTICLE 1: GENERAL

1.01 General

- A. These Supplementary Conditions amend or supplement the General Conditions and other provisions of the Contract Documents as indicated below.
- B. All provisions which are not so amended or supplemented remain in full force and effect.

1.02 Project Representative and Engineer

- A. The Project Representative is the sole point of contact for the Contractor on matters relating to the Work. The Project Representative for this Project is Randy Van Hoozer, rvanhoozer@tmwa.com, 775-834-8011.
- B. The Project Engineer for this project is Chris Struffert, cstruffert@tmwa.com, 775-834-8047.

ARTICLE 2: CONTRACTOR'S INSURANCE - Not Used

ARTICLE 3: PERMITS

3.01 General

- A. Refer to Article 6.06 "Permits" of the General Conditions for requirements governing responsibility for obtaining permits and paying permit fees.

3.02 Construction Site Stormwater Permit

- A. Refer to Article 6.14 "Construction Site Stormwater Control" of the General Conditions for additional requirements.
- B. The estimated area of land that will be disturbed by the Project is less than one acre therefore the Contractor is not required to prepare a SWPPP or file a NOI with NDEP.

3.03 Dust Control Permit

- A. Refer to Article 6.15 "Dust Control" of the General Conditions for additional requirements.
- B. The estimated area of land that will be disturbed by the Project is less than one acre therefore TMWA will not obtain a dust control permit from the Washoe County Health District.

ARTICLE 4: ACCESS TO WORK SITE

4.01 General

- A. Refer to Article 4.01 of the General Conditions for general requirements governing availability of lands.
- B. The Contractor, and not TMWA or its representatives, shall be responsible for exercising reasonable precautions for the safety of employees on the work site and complying with any applicable provisions of federal, state, and municipal safety laws and building and construction codes. The Contractor shall promptly report to the TH all accidents involving the Contractor's employees.
- C. Safety of the public shall be provided for at all times while work is in progress including weekends, holidays, and after working hours. The Contractor shall plan his operations to insure a safe work area for employees and the public.

ARTICLE 5: DOCUMENTS FOR CONSTRUCTION

5.01 General

- A. TMWA will prepare conformed Specifications for construction that incorporate all addenda issued during bidding.
- B. TMWA will provide up to six sets of the conformed documents to the Contractor for use during construction. Additional sets can be obtained at cost.
- C. Only conformed documents shall be used for construction. TMWA will not compensate the Contractor for incorrect work done as a result of not using the conformed Documents.

5.02 Ownership of Documents

- A. Per Article 3.06 “Ownership and Return of Contract Documents” of the General Conditions, ownership of the Contract Documents remains with TMWA. All copies shall be returned to the Project Representative before payment will be made for demobilization and before a Notice of Completion will be filed.

ARTICLE 6: PROJECT CLOSEOUT

6.01 General

- B. Refer to Article 7.06 “Retention and Final Payment” of the General Conditions for additional information.
- C. Project closeout starts when the Contractor submits a letter to the Project Representative stating that the Project is complete and requesting release of retention.
- D. The project closeout process is part of the Work and must be completed within the specified Contract Time.

6.02 Procedures

- A. Upon receipt of the Contractor's letter, the Project Representative will determine if the Project has been completed as required by the Contract Documents. To be considered complete:
1. The Project shall be in service or be ready to be placed in service.
 2. All punch list items shall be completed to the satisfaction of the Project Representative.
 3. The final conforming Change Order shall be signed by the Contractor and be ready for execution by TMWA.
 4. The retention release pay request shall be submitted and approved by the Project Representative.
 5. All copies of the Contract Documents shall be returned to the Project Representative.
 6. All conditions of the Project permits shall be fulfilled. Evidence of acceptance or sign off by each permitting agency shall be submitted to the Project Representative.
 8. The following items shall be submitted and approved by the Project Representative:
 - i. Warranties.
 - ii. Test reports and certifications.
 - iii. Operation and Maintenance manuals.
 - iv. Spare parts.
 - v. Special tools.
 - vi. If the Contractor utilized other property for staging, equipment storage, stockpiling, or similar uses, a written statement from each property owner stating that all provisions of the agreement between the Contractor and property owner have been complied with.
- B. If the Project is complete, the Project Representative will submit the required documentation to TMWA's Contracts Administrator and request that the Notice of Completion be issued. The one year warranty required by Article 6.18 "Warranty" of the General Conditions shall start on the date of the Project Representative's determination that the project is complete.
- C. If the Project is not complete, the Project Representative will notify the Contractor in writing of items that need to be completed or submitted before the Project will be considered complete.

ARTICLE 7: PROJECT MILESTONES

7.01 General

- A. Refer to Article 3 of the Agreement, the Definitions contained in the General Conditions and Article 2.05 of the General Conditions for additional information.
- B. Time is of the essence on this construction Contract and the Work shall be one hundred percent (100%) complete no later than the date specified in the Agreement. As defined in the Agreement, the Time of Completion is based on a specific number of calendar days after the date of the Notice to Proceed (NTP).
- C. The date of the NTP starts the Contract Time. Contract Time is defined in the General Conditions. Contractor shall not move onto, store materials at, or perform any work at the site prior to the Notice to Proceed being issued. Any mobilization of labor, material or equipment by Contractor prior to TMWA issuing the Notice to Proceed is done at the sole risk and expense of the Contractor, and shall not modify the Contract Time. The allotted Contract Time includes all preliminary Work tasks including permits, surveying, potholing, submittals, etc.

The tentative overall project schedule is shown below. The actual project schedule may be slightly different depending upon whether the milestones below are met.

Advertise - Plan Set Distribution	July 7, 2015
Bids Due	July 31, 2015
Recommendation of Award Issued	August 03, 2015
Pre-Construction Meeting	August 24, 2015
Notice to Proceed	August 24, 2015
Start Construction	Negotiable, anticipate on or before October 1, 2015
Work 100 Percent Complete	December 24, 2015

END OF SUPPLEMENTARY CONDITIONS

Section 01030

SPECIAL PROVISIONS

ARTICLE 1: GENERAL

1.01 GENERAL

- A. These Special Provisions amend or supplement the General Conditions and other provisions of the Contract Documents as indicated below.
- B. All provisions which are not so amended or supplemented remain in full force and effect.

1.02 ADDITIONAL DEFINED TERMS

Development, airlift - Airlift development is the process for cleaning out the drilling mud and loose fine grain sediment after the casing and gravel pack is installed and is undertaken using the drill rig with open-ended drill pipe with well-bore-hole-swab tool attached.

Development, airlift/double-swab – After the initial airlift development phase is completed, airlift/double-swab development utilizes the drill rig to develop the screen sections of the well casing, which may include the placement chemicals, in order to further clean the well prior to removal of the drill rig.

Development, double-swab pump – As part of developing a new well and following airlift/double-swab development, double-swab pump development involves running the double-swab tool which houses an enclosed pump inside the swab tool up and down across each screen section to remove sediment from the well.

Development, well pump – Well pump development is undertaken at a new well after airlift development, airlift/double-swab development, double-swab pump development when a test pump is installed so as allow for varying the rate of pumping of the test pump to discharge (surge) water from the well.

Drill Cuttings - Drill cuttings are the geologic material that is cut by the well drill and is removed from the well by the circulation of drilling mud during the drilling process.

Drilling Fluid - Drilling fluid is defined as the fluid that is removed from the well after installation of the casing and during the initial airlift development phase. The drilling fluid usually has a viscosity in the range of 28-35 seconds.

Drilling Mud - Drilling mud is typically a bentonite and polymer mixture that is used during the drilling of the borehole to lift drill cutting from the well and to provide stability to the borehole prior to installation of the well casing. Drilling mud usually has a viscosity in the range of 35-45 and is removed from the site with the drill cuttings.

Pumping Test - Pumping tests take place with a test pump or a production pump and can vary in duration and pump rate. For example, a “step test” may be 3 or 4 steps at increasing pumping rates for 2 hours interval or a “constant-discharge” pump test may be 72-hours at a constant pump rate.

TMWA Hydrogeologist (“TH”) – TMWA employee (or TMWA contracted personnel) whose responsibility to provide on-site hydrogeologic analysis and assessment of the drilling process and advise the Project Representative of necessary changes to the process as conditions warrant. The TH and Project Representative may be the same individual.

1.03 OWNER-FURNISHED MATERIAL

All material and equipment shall be provided by Contractor. No material will be provided by TMWA.

1.04 DISPOSAL OF WATER

TMWA has or will obtain the following permits related to disposal of water.

- A. Nevada Division of Environmental Protection (NDEP) No. NV00224031 to discharge fluids into the Dry Creek/Boynton Slough, which is located approximately 1,200 feet west of the proposed Innovation Well site. A copy of the Permit issued by NDEP will be furnished to the Contractor. A copy of the permit shall be in the possession of the well driller at the drill site at all times. **It is the responsibility of the Contractor to comply with all conditions of the Permit.**
- B. Nevada Division of Water Resources (NDWR) Permit No. 70409. A copy of the Permit issued by NDWR will be furnished to the Contractor. It is the responsibility of the Contractor to file the “Intent to Drill” notice and the “Well Drillers Report” with NDWR at the proper times. A copy of the permit shall be in the possession of the well driller at the drill site at all times.
- C. TMWA will apply for a drilling permit from the Washoe County District Health Department. The Contractor shall furnish, with the bid, copies of his current business and contractor licenses showing that the Contractor is licensed to drill in Nevada and in the jurisdiction of local authorities for use in obtaining this permit. This permit must be kept on site at all times.
- D. The Contractor is responsible for complying with all conditions of the above listed permits, and is referred to Article 3 of the Supplementary Conditions for general permit requirements.

1.05 DISPOSAL OF DRILLING FLUID, DRILLING MUD, DRILL CUTTINGS, AND OTHER DRILLING WASTES

- A. Subject to appropriate permitting, water from airlift development, airlift/double swab development, double-swab pump development and test pumping may be: (1) discharged to a drainage system; (2) removed from site either by a vac truck; or (3) through a pipeline to its discharge point provided for under TMWA’s existing OM discharge

Before commencing drilling operations, the Contractor shall submit a detailed written plan to the TH and the Project Representative for all such water disposal and shall obtain approval from the Project Representative of such plan. This approval, however, shall not make TMWA responsible for the adequacy of such plan, or for obtaining any permits for the Contractor, or to any other party for any damage or loss occasioned by the disposal of the water under this section.

- B. The Contractor shall monitor the flow into the drainage system and shall not allow discharge of water that will cause pollution or that will leave deposits of sediment in storm drainpipes or channels. **Water with suspended solids concentrations exceeding 10 mg/L or with turbidity exceeding 100 NTU shall not be disposed of in the drainage system.**
- C. The Contractor shall arrange his operations and equipment so that the flow rate, suspended solids, and other measurements required by these specifications can be made and so any required samples for analysis can be taken. All items installed by the Contractor shall be removed when they are no longer required. TMWA will not allow installation or use of any temporary facility that would interfere with or affect the construction of future facilities on the site.

1.06 CONSTRUCTION UTILITIES

- A. Contractor shall coordinate all construction and required inspections with utility companies impacted by the project. All existing utilities shall be preserved. Any damage or loss of service caused by Contractor shall be at Contractor's expense.
- B. All utilities are to be located by USA a minimum of two days prior to start of construction.
- D. Water for the drilling and testing operations may be obtained from one the fire hydrant near the site approximately 150 feet south of the property. It is the responsibility of the Contractor to coordinate with the City of Reno authorities, and the Project Representative for the use of the hydrant water, and for proper installation of a backflow protection device as required by TMWA.

The Contractor shall be responsible for supplying all other water at the drilling site. Water for dust control and other construction purposes shall be obtained from a construction water source at the expense of the Contractor.

- E. If engine-driven generators are used they shall be equipped with residential type critical silencers and able to meet the local noise level limit of 65 decibels at the property boundary. Failure to meet this noise level limit will necessitate the removal of the faulty equipment.
- F. Temporary sanitary facilities shall be provided and maintained by the Contractor for use by the Contractor's employees and the TMWA representatives at a convenient location on the site.

- G. A telephone shall be available at the site at all times when work is in progress. The Contractor's foreman and superintendent shall have a cellular phone. All phone numbers shall be furnished to the TCH and the Project Representative.

1.07 PRE CONSTRUCTION CONFERENCE

Prior to the commencement of the Work, a pre-construction conference will be held. The purpose of the meeting is to designate personnel and establish a working relationship between the parties. Matters requiring coordination will be discussed and procedures for handling such matters established.

The work site is located on TMWA property, adjacent to at the northeast corner of the Charles River Laboratories, Inc. building located on Longley Lane and the western intersection of Innovation Drive with Longley Lane (see Figure 1). The pre-construction conference ("Precon") shall be the only opportunity for the Contractor to examine the area and make all necessary investigations to be thoroughly informed as to the facilities and area available for delivering, placing, and operating necessary equipment, and for delivering and handling all materials at the site.

It is the Contractor's responsibility to investigate the project area sufficiently to be thoroughly satisfied as to the conditions he may expect to encounter. No plea of ignorance of conditions that exist or of conditions or difficulties that may be encountered in the execution of the work under this contract will be accepted as an excuse for any failure or omission of the Contractor to fulfill in every detail all of the requirements of the contract, nor will such be accepted as a basis for any claim whatsoever for extra compensation or for an extension of time.

The following groups shall attend the Precon:

- Contractor and his Superintendent
- Principal Sub-contractors
- TMWA and its project representatives

The meeting shall discuss, but is not limited to, the following topics:

- Review and distribution of Contractor's submittals
- Construction/contract management
- Field Decisions, Change Orders, and Chain of Command
- Construction and pumping schedule
- Processing applications for payment
- Documentation of drilling and pump testing per Bid Documents
- Office and Storage Areas
- Major Equipment Deliveries and Priorities
- Safety
- Traffic Control Measures
- Other

The following table indicates those parties with general responsibility for the discussion topics set forth above.

Contractor	Proj. Eng	TH	
	S	P	Review and distribution of Contractor's submittals
	S	P	Construction/contract management
	S	P	Field Decisions, Change Orders, and Chain of Command
	S	P	Construction and pumping schedule
	S	P	Processing applications for payment
	S	P	Documentation of drilling and pump testing per Bid Documents
P			Office and Storage Areas
P			Major Equipment Deliveries and Priorities
P			Safety
P			Traffic Control Measures
tbd	tbd	tbd	Other

NOTES: P-Primary responsibility; S-Secondary responsibility

1.08 MATERIALS AND WORKMANSHIP

Unless otherwise specified, all materials shall be new, and both workmanship and materials shall be of prime quality. The Contractor shall, if required, furnish satisfactory evidence as to the kind and quality of materials. In any case, all pipe, valves, and other equipment the Contractor furnishes for the completed project shall be new and of prime quality.

1.09 HOURS OF WORK AND SIGNAGE

Work hours are as specified in Section 2.09 of the General Conditions unless otherwise agreed by the Project Representative for required specific tasks, such as installation of casing, gravel pack or pumping tests. Working on Saturday, Sunday, and holidays is subject to the approval of the Project Representative. The Project Representative and/or TH will provide guidance as regards workdays and work hours.

Standby time will not be paid for performance of any of the required work described in these Specifications. **It is the Contractor responsibility to schedule equipment, material delivery, sub-contractors, starting time of his operations, and all other items under his control so that no delay to his operations occurs.**

Hard hat area and keep out signs will be required. However no project sign is allowed.

1.10 DAILY REPORTS

The Contractor or Contractor's field representative shall report plans and progress to the TH and the Project Representative approximately 24 hours before pumping is to be started and daily thereafter during the course of pump testing of the well. The Contractor shall submit two copies of the daily reports, one each to the TH and the Project Representative. These reports are due by 8 am on the morning following the previous work day. The exception being Friday's and Saturday's reports will be due Monday at 8:00 am.

The TH and TMWA's Project Representative shall approve the form of the tour progress report. All data pertaining to drilling progress, such as drilling depth, formation descriptions, tallies of materials set during construction work, and development and pumping time, shall be recorded accurately on these reports during each tour. The Contractor's foreman in charge of tour reporting shall prepare each tour report. A "tour" is defined as the period of time a driller and crew work continuously without interruption.

1.11 RECORD DRAWINGS - N/A

END OF SECTION

**Section
33211**

**WATER SUPPLY WELLS DRILLING AND
CONSTRUCTION**

PRODUCTION WELL DRILLING, CONSTRUCTION, DEVELOPMENT, AND TESTING

PART 1 GENERAL

A. SCOPE

This section includes a detailed description of production well construction work and requirements.

The work to be performed includes furnishing all labor, materials, transportation, tools, supplies, plant equipment and appurtenances, and incidentals to the project; the establishment of offices, buildings and other facilities necessary for work on the project; premiums or bonds and insurance; and for all other work and operations which must be performed or costs incurred before beginning work on various contract items; unless hereinafter specifically excepted, necessary to the complete and satisfactory construction, development and testing of two (2) water production wells:

- Innovation Well: 310 feet total depth, nominal 14-inch diameter production well.
- Army Aviation Well: 620 feet total depth, nominal 18-inch diameter production well.

Figure 1 shows the locations of the two production well sites. The sites are approximately 18 miles apart and within the TMWA water service area.

The two production wells shall be drilled by the Flooded Reverse Circulation method. Only threaded (not flanged) drill pipe is acceptable.

The geologic formations are expected to be unconsolidated fine- to coarse-grained material (clay, silt, sand, and gravel) throughout the borehole length at both locations.

All work and materials shall conform to the American Water Works (AWWA) A100-06 standards with supplemental standards as set forth in American Society for Testing and Materials (ASTM) 778 and 139 for the use of flooded reverse circulation drilling, and the American Welding Society (AWS), where appropriate.

B. MATERIALS

The drilling contractor shall provide all equipment, materials, and tools necessary to perform all work.

1. EQUIPMENT AND OPERATING REQUIREMENTS

TMWA shall have the right to approve or reject the types of drilling rig and equipment used, but approval will not remove the contractor's responsibility to furnish equipment to adequately complete the work in an efficient and timely manner, as specified herein. Equipment shall have sufficient capacity to adequately construct the wells, as specified herein, and shall include the following accessory equipment:

- a. Portable, self-contained fluid circulation system with operational desanders and shale-shaker.
- b. All appropriate pressure gauge(s).
- c. Weight indicator.
- d. Drill collars for added weight during early stages of drilling.
- e. Plastic sheeting or drip pans will be placed under the drill rig and all motorized equipment associated with drilling operations, development pumping and test pumping to prevent soil contamination from the equipment.
- f. The means to clean tires and equipment such that public streets are kept clean. Contractor shall keep all roads, utilized by contractor vehicles and equipment, clean to city/county requirements.
- g. All materials used in the drilling, construction, development, and testing of the borings and wells shall be Certified Well Drilling Aids and Well Sealants as identified by the American National Standards Institute (ANSI)/NSF International (NSF) STD 60 and American Water Works Association (AWWA) A100 Standards and approved for public water supply wells. This includes but is not limited to lubricants, adhesives, foaming agents, well sealants, drilling fluids, drilling aids, and any other materials necessary to complete the work.

C. WORKMANSHIP

1. DRILLING FLUID CONTROL

It is expected that implementing the flooded reverse circulation method to drill the production wells will require minimal drilling fluid. The Contractor shall develop and provide a written drilling fluid program before mobilization to each drilling site. The drilling fluid program shall address all components of the non-invasive drilling appropriate for the flooded reverse circulation method, including but not limited to: portable pit size and design, mixing pumps and hopper to produce effective shear and velocity to settle out cuttings, mix volumes of all fluid components, appropriate methods for measuring fluid properties (weight, viscosity, sand content, cake thickness), and solids control equipment (desanders, desilters, shakers, centrifuges). The drilling

fluid shall contain additives that are recognized by the ANSI/NSF STD 60 and AWWA A100 Standards as appropriate for drilling in a fresh water aquifer. It is the Contractor's responsibility to maintain a fluid system containing a minimum of clay and fine sand so that any filter cake can be easily removed from the face of the borehole. In the event of a conflict between the fluid requirements for ease in drilling and the fluid requirements for protection of the aquifer, then the ruling requirements shall be those for aquifer protection.

All drilling fluid components and additives shall be approved by the Owner prior to use. If approved, components and additives shall be used according to manufacturer specifications. The Contractor is responsible for providing the necessary equipment and qualified personnel for performing all drilling fluid monitoring and measurements. **Copies of all recorded measurements will be supplied to the Owner.**

If in the opinion of the Owner that drilling fluid is not mixed in the best interest of aquifer protection, the Owner may require the Contractor to obtain the services of a qualified drilling fluid engineer. The Contractor shall be responsible for any payment required for the services of the engineer. The engineer shall be responsible for maintaining drilling fluids properties in a manner that protects the aquifer. The Contractor shall monitor and maintain the fluid properties as outlined by the engineer. In the event the Contractor cannot attain the required fluid properties, the fluid shall be replaced at no additional cost to the Owner.

2. PRODUCTION WELL DRILLING AND CONSTRUCTION DETAILS

The project consists of drilling and constructing two (2) water production wells: the Innovation well and the Army Aviation well. The project may be stopped at any time during the production borehole drilling or testing of the production well, if water quality and/or water quantity are found to be insufficient for production well purposes. The Innovation well shall be nominal 14-inch diameter while the Army Aviation well shall be nominal 18-inch diameter. The wells shall consist of high strength low alloy (HSLA) steel conductor casing and 304L stainless steel blank casing. The screen for the Innovation well shall be 304L stainless steel wire wrap. The screen for Army Aviation shall be 304L stainless steel louvered. All casing and screen shall be manufactured in accordance with the applicable parts of ASTM 778. Each well shall be drilled and constructed according to the attached Figures 2 and 3, and meet the specific requirements of the Screen and Casing tables below.

Army Aviation Well 18" Screen Requirements*	
Welding	Automatic submerged arc, inside and outside passes
Nominal wall thickness	0.375"
Minimum wall thickness	Not less than 95% of nominal wall thickness
Ovality	Not more than 1% of nominal diameter
Straightness	Maximum 0.125" deviation along 10-ft straight edge
End section perpendicularity	Maximum 0.010" deviation from true perpendicular plane
Screen openings	Machine made, horizontal to the axis of the casing, louver form with downward-facing openings. Aperture size shall be 0.090" slot with 14 openings/circle and 168 openings/foot.

Innovation Well Screen and Casing*	
Starter casing of nominal steel pipe size (if required by contractor)	Contractor choice
Borehole diameter from surface to 40 feet	30-inch
Blank casing, 0.312-inch wall from surface to 40 feet	24-inch
Borehole diameter from 40 to 310 feet	24-inch
Blank stainless steel casing, 0.312-inch wall	14-inch
Stainless steel wire-wrap screen, 0.080-inch slot, 0.312-inch wall	14-inch
Total cased depth	300 feet

Army Aviation Well Casing*	
Starter casing of nominal steel pipe size (if required by contractor)	Contractor choice
Borehole diameter from surface to 40 feet	36-inch
Blank casing, 0.312-inch wall from surface to 40 feet	30-inch
Borehole diameter from 40 to 620 feet	26-inch
Blank stainless steel casing, 0.375-inch wall	18-inch
Total cased depth	610 feet

* Nominal casing and screen diameters

2.1 Mobilization. Mobilization consists of all preparatory work and operations as defined in Section 7.01 of the General Conditions.

2.2 Markup Allowances. Covered in Section 7.04 G of the General Conditions.

2.3 Innovation Well Drilling and Construction Details

2.3.1 Drill/Install/Grout a 30-inch borehole and nominal 24-inch diameter surface conductor casing to a depth of 40 feet using the Mud Rotary method. Payment shall be made at the contract lump sum and shall be full compensation for furnishing all materials, labor, equipment, tools, and appurtenances necessary to complete the work. This item includes, but is not limited to, drilling, installation of one surface casing, and installation of 4 cubic yards of grout via tremie method from ground surface to 40 feet below land surface. The owner has determined the design of the conductor, but this design may change. Design changes will not interfere with the progress of the conductor installation. No payment shall be made for over-drilling as desired by the Contractor.

Surface conductors for the production wells shall consist of high-strength low alloy (HSLA, A606 type 4) steel free of any coating matter, and manufactured in accordance with applicable parts of ASTM Standard A 139 Grade B. The surface conductor casing shall be spiral welded, fabricated or mill-type. All pipe shall be in compliance with AWWA A100 Standards. The surface conductor casing shall have a wall thickness of 0.312 inches. Conductor casing wall thickness must meet or exceed requirements per *Regulations for Water Well and Related Drilling, Nevada*

2.3.2 Drill one (1) 24-inch production borehole with the Flooded Reverse Circulation method. Payment shall be made at the unit price per linear foot and shall be full compensation for furnishing all materials, labor, equipment, tools, and appurtenances necessary to complete the work. This item includes but is not limited to: drilling of one production boring using the flooded reverse circulation method. The 24-inch diameter production boring shall be drilled from the bottom of the surface conductor boring (40 feet) to total depth of 310 feet below land surface.

The owner has determined the design of the boring, but this design may change. Design changes will not interfere with the progress of the boring. No payment shall be made for over-drilling as desired by the Contractor.

2.3.3 Provide borehole geophysical logging. Payment shall be made at the unit price per each and shall be full compensation for furnishing all materials, labor, equipment, tools, and appurtenances necessary to complete the work. This item includes, but is not limited to providing spontaneous potential, resistivity, and caliper logging services.

The contractor shall be responsible for providing standard water well geophysical logs conducted by an Owner-approved, commercial logging services sub-contractor and performed in the presence of the Owner. The logs shall be presented in hard copy standard format and in electronic format on DVD. The logs shall consist of spontaneous potential, resistivity (point, short normal, long normal and lateral), and caliper and conducted once every 100-feet of drilled borehole. Any footage over 300 feet but less than 350 feet shall be logged as incidental to the unit price per each of this bid item. The entire borehole shall be logged as determined by the Owner.

2.3.4 Furnish/Install 10 linear feet of nominal 14-inch diameter, a minimum of 0.312-inch wall thickness, 304L stainless steel sump placed from a depth of 290 feet to 300 feet. Payment shall be made at the contract unit price per linear foot and shall be full compensation for furnishing all materials, labor, equipment, tools, and appurtenances necessary to complete the work. This item includes, but is not limited to the supply and installation of one production well sump.

Production casing shall have a pipe weight of 48.46 lbs/ft for the Innovation well. Casing shall be furnished in 20-foot lengths with 10-foot lengths to complete the casing program. Casing shall be manufactured with welded collars attached.

The stainless steel sump shall be manufactured in conformance with ASTM A778. The sump shall be affixed to the bottom of the well screen using a welding collar. The well sump shall have a bull-nosed bottom constructed of 304L stainless steel and have a nominal diameter of 14 inches and a minimum wall thickness of 0.312 inches or as recommended by the manufacturer for the total length of well casing and screen to be constructed, whichever is thickest. All blank casing (sump and bull-nose bottom) shall be of new, first quality materials and free of defects in workmanship and handling. No reject, sub-grade or limited-use pipe is acceptable.

The owner has determined the design of the production well sump, but this design may change. Design changes will not interfere with the progress of the production well sump installation.

2.3.5 Furnish/Install 100 linear feet of nominal 14-inch diameter, a minimum of 0.312-inch wall thickness, 304L stainless steel wire-wrap screen placed at depths according to the well construction schedule shown in Figure 2. Payment shall be made at the contract unit price per linear foot and shall be full compensation for furnishing all materials, labor, equipment, tools, and appurtenances necessary to complete the work. This item includes, but is not limited to the supply and installation of 100 feet of production well screen.

The stainless steel well screen shall be 0.080-inch slot for the nominal 14-inch Innovation well. The screen shall be furnished in 20-foot lengths with 10-foot lengths to complete the screening program. Well screen shall be manufactured by Roscoe Moss Corporation (or approved equal).

Well screen shall be in conformance with ASTM A778. The screens sections shall be manufactured with the welded collars. Collars shall be the same thickness, physical, and chemical properties as the corresponding casing or screen section. Collars must be 5 inches in width, rolled to fit the outside diameter, and factory welded to one end of each section. The inside edge of the collars shall be free of sharp edges and burrs. Section ends shall be machined flat perpendicular to the axis of the casing or screen and shall not vary more than 0.010 inch at any point from a true plane at right angles to the axis of the casing or screen. Three (3) one and one sixteenth (1-1/16)-inch diameter inspection windows must be provided in each collar to ensure proper matching of the sections during the welding process to join sections.

Screen shall have a minimum wall thickness of 0.312 inches or as recommended by the manufacturer for the total length of the well casing and screen to be constructed, whichever is thickest. All screen shall be of new, first quality materials and free of defects in workmanship and handling. No reject, sub-grade or limited-use pipe is acceptable.

The owner has determined the design of the production well screen, but this design may change. Design changes will not interfere with the progress of the production well screen installation.

2.3.6 Furnish/Install 190 linear feet of nominal 14-inch diameter, a minimum of 0.312-inch wall thickness, 304L stainless steel blank casing according to the well construction schedule shown in Figure 2. Payment shall be made at the contract unit price per linear foot and shall be full compensation for furnishing all materials, labor, equipment, tools, and appurtenances necessary to complete the work. This item includes, but is not limited to the supply and installation of 190 feet of production well casing.

Production casing shall have a pipe weight of 48.46 lbs/ft for the Innovation well. Casing shall be furnished in 20-foot lengths with 10-foot lengths to complete the casing program. Casing shall be manufactured with welded collars attached.

The stainless steel casing shall be manufactured in conformance with ASTM A778. The casing shall be affixed to the bottom of the well screen using a welding collar. The well casing shall be constructed of 304L stainless steel and have a nominal diameter of 14 inches and a minimum wall

thickness of 0.312 inches or as recommended by the manufacturer for the total length of well casing and screen to be constructed, whichever is thickest. All blank casing shall be of new, first quality materials and free of defects in workmanship and handling. No reject, sub-grade or limited-use pipe is acceptable.

The owner has determined the design of the production well sump, but this design may change. Design changes will not interfere with the progress of the production well casing installation.

Casing, screen, and sump shall be installed using methods approved by the Owner. The production well casing, well screen, and sump shall be suspended as a unit above the bottom of the hole at a sufficient distance to insure that no portion of the well is supported by the bottom of the borehole. The suspended casing unit shall be firmly secured at the surface until gravel and seal are permanently installed.

The well casing and screen shall have stainless steel centering guides approved by the Owner. The centering guides shall be installed at 40-foot intervals (four centralizers per interval) along the well screen and blank casing, or as otherwise approved by the Owner.

Welders completing field assembly of the well casing, screen, and sump shall be qualified in accordance with the latest revision of the section titled, Welding Procedures of the American Welding Society (AWS) Standard Qualification Procedure. All welds shall be continuous, watertight, fully penetrating fillet welds (joining sections and inspection/centering holes), and completed in accordance with AWS Standards and AWWA C206.

2.3.7 Furnish/Install Gravel Feed Tube, Injection Tube, and Water Level Sounding Tubes – Contractor shall provide materials, equipment, and labor necessary to install: one (1) nominal 3-inch gravel feed tube open to the top of the gravel pack; one (1) nominal 3-inch injection tube; and one (1) nominal 2-inch stainless steel sounding tube. All tubes shall be equipped with water-tight caps above ground.

Contractor shall provide materials, equipment, and labor necessary to install to 124 feet, 4 feet below the bentonite seal, of nominal 3-inch stainless steel gravel feed tube open to the top of the gravel pack to allow for future addition of gravel, if necessary. The gravel feed tube shall be constructed of nominal 3-inch diameter, 0.216-inch wall thickness, 304L stainless steel manufactured in conformance with ASTM A778. The gravel feed tube shall be encased in the sanitary grout seal and shall be open at the bottom to allow for placement of addition of gravel after the sanitary grout seal is installed. The gravel feed tube shall be equipped with a water tight cap.

Contractor shall provide materials, equipment and labor necessary to install 92 feet of nominal 3-inch stainless steel injection tube. The injection tube shall be constructed of nominal 3-inch diameter, 0.216-inch wall thickness, 304L stainless steel manufactured in conformance with ASTM A778. The injection tube shall be encased in the sanitary grout seal. The bottom of the injection tube will attach to the casing at a Roscoe Moss (or approved equal) entrance chamber box (Figures 4 and 5) positioned 90 feet below land surface. The entrance chamber box shall be welded to the well casing according to manufacture specifications.

The stainless steel sounding tube shall be 212 feet and constructed of nominal 2-inch diameter, 0.20-inch wall thickness, 304L stainless steel manufactured in conformance with ASTM A778. The stainless steel sounding tube shall be attached to the outside of the well casing with stainless steel bands. The sounding tubes shall be encased in the sanitary grout seal and gravel pack. The bottom of the sounding tube will enter the casing at a Roscoe Moss (or approved equal) entrance chamber box positioned 210 feet below land surface. The entrance chamber box shall be welded to the well casing according to manufacture specifications.

The owner has determined the design of the gravel feed, injection, and sounding tubes, but this design may change. Design changes will not interfere with the progress of the production well screen installation.

2.3.8 Furnish and install a 1/8-inch x 1/4-inch gravel pack in the well annulus via tremie pipe. Payment shall be made at the contract unit price per cubic yard and shall be full compensation for furnishing all materials, labor, equipment, tools, and appurtenances necessary to complete the work. This item includes, but is not limited to the supply and installation of 15 cubic yards of gravel pack via tremie pipe from 120 feet to 310 feet below land surface. The owner has determined the design of the gravel pack, but this design may change. Design changes will not interfere with the progress of the gravel pack installation.

Drilling fluid will be closely monitored throughout the drilling process to minimize borehole wall cake development prior to placement of gravel pack. Gravel pack shall be placed by tremie pipe in the annulus between well casing and borehole sidewall. Gravel pack shall be composed of washed, sound, durable, well-rounded particles containing no silt, clay, organic matter or deleterious materials. Gravel pack shall meet specifications as per AWWA A100-06. Gravel pack shall be delivered and stored at the drill site in protective bags. Gravel pack shall be manufactured by a company specializing in water well gravel pack such as SRI Supreme or approved equal. The Contractor shall supply Owner with an invoice stating quantity, gradation, and well screen compatibility for the gravel pack delivered to the drill site.

The Contractor shall determine when conditions are satisfactory for gravel pack placement. Gravel pack shall be placed through a tremie pipe installed to the depth specified by the Owner. Only potable water and disinfectant shall be mixed with the gravel pack during placement. Shoveling or end-dumping with a loader of gravel-pack directly into the borehole is not permitted. The gravel pack shall be disinfected by adding a minimum of twenty (20) pounds of 65-70%-granulated calcium hypochlorite to the gravel pack during placement. The calcium hypochlorite shall be evenly distributed throughout the gravel pack. The gravel tremie pipe shall be removed after placement.

The Contractor shall place the gravel in the annulus without bridging, such that there are no voids. Bridging of gravel pack shall be assumed if the volume of gravel-pack placed is less than 90% of the calculated annular volume for the total borehole depth. If bridging is identified by the above calculation, the bridging shall be corrected at the contractor's expense without damage to the casing, screen, sump, or borehole, or drill a new borehole and install new casing, screen, and sump to the satisfaction of the Owner. If the Contractor chooses to drill a new well, he shall be responsible for all costs associated with properly drilling the new well and properly abandoning the failed well.

2.3.9 Furnish and install bentonite pellet and sanitary seal to surface via tremie pipe.

Payment shall be made at the contract unit price per cubic yard and shall be full compensation for furnishing all materials, labor, equipment, tools, and appurtenances necessary to complete the work. This item includes, but is not limited to the supply and installation of 0.5 cubic yards of bentonite pellets above the gravel pack from 116 feet to 120 feet, and 10 cubic yards of cement grout seal via tremie pipe from land surface to 116 feet. The owner has determined the design of the sanitary seal, but this design may change. Design changes will not interfere with the progress of the sanitary seal installation.

The bentonite pellets and cement grout shall be placed by positive displacement through a tremie pipe or by the Haliburton method. Cement grout shall be placed within 30 minutes of mixing. The cement grout slurry shall consist of equal parts of cement and sand with 6 gallons of clean water for one 94-pound sack of Portland type C cement (or as defined in NAC 534.060 of *Regulations for Water Well and Related Drilling, Nevada Department of Conservation and Natural Resources, Division of Water Resources, revised 2014*). The slurry shall be thoroughly mixed and free of lumps and stones and put through a protective strainer before pumping into the well. The final mix shall produce a slurry weight of 15.6 pounds per gallon. Calcium chloride, bentonite or other additives are not allowed. The slurry shall be placed in one continuous operation once the process begins. The sanitary seal shall be left undisturbed for a minimum of 24 hours after the final batch or lift of slurry has been placed. No standby time shall be paid during this period.

The Contractor shall provide an invoice stating the quantity of slurry placed into the annulus.

2.3.10 Well Development by Mechanical Method. Payment shall be made at the contract unit price per hour and shall be full compensation for furnishing all materials, labor, equipment, tools, and appurtenances necessary to complete the work. This item includes, but is not limited to the development of the well using the dual swab and simultaneous airlift development method.

Contractor shall provide all materials, equipment and labor necessary to develop the well. Well development shall progress in three phases:

1. Predevelopment
2. Mechanical Development
3. Pump Development

Predevelopment shall occur during the drilling of the well by the Contractor using proper drilling additives (those essential for flooded reverse drilling), as specified above. Contractor shall minimize the use of drilling additives. Drilling fluids shall be conditioned (thinned), if necessary, to a minimum before installation of casing and gravel-pack to ensure ease of additive removal during subsequent development phases.

Mechanical development shall begin with the dual swab and simultaneous airlift development method. Surge blocks shall be snug-fitting double-flanged with perforated pipe and fabricated according to the diagram shown in Figure 6. Dual swab and simultaneous airlift development shall proceed by vigorously raising and lowering the drill pipe starting at the top of the screen to

minimize the risk of sand locking the swabs. Surge and airlift development shall follow the procedures described on pages 514 and 515 of *Groundwater and Wells, Second Edition, Fletcher Driscoll, Johnson Filtration Systems*. The compressor for development shall have a minimum capacity to unload 290 feet of water from an airline setting of 300 feet below ground surface. The compressor shall produce a minimum air volume of 325 cubic feet per minute at 150 psi. Development by surging shall begin at the bottom of the screen and shall gradually move upward to the top of the well.

If necessary, the Contractor will use a dispersing agent during airlift development to facilitate the breakdown of drilling additives (if used) remaining from drilling operations. **Use of phosphate products such as sodium acid pyrophosphate (SAPP) during well development is not allowed.** The Contractor shall use a dispersing agent as recommended by the manufacturer for wells of this diameter, depth and formations penetrated. Documentation of application volumes, ratios and method of introduction shall be submitted to the Owner prior to product use. The dispersant will be mixed thoroughly, injected into the well, swabbed into the well from the bottom up after injection, and then allowed to remain undisturbed overnight. No stand by time will be paid during this period. Mechanical well development by double-swab will continue at ten (10)-foot intervals until dispersant treatment is complete. Upon completion of dispersant treatment, mechanical well development by surging will continue at ten (10)-foot intervals until, in the opinion of the Owner, well development is complete. A total of 40 hours of mechanical and airlift development is anticipated.

Contractor shall control and contain all drilling cuttings and dispose of it at the TMWA Glendale plant. Contractor shall properly dispose of all development and testing water in accordance with applicable local, State, and Federal requirements and obtain necessary permits. **Disposal of water to Dry Creek, located approximately 1,200 feet to the west, shall only be allowed if a temporary discharge permit is approved by Nevada Division of Environmental Protection.** The Contractor shall monitor the flow into the drainage system and shall not allow discharge of water that will cause pollution or that will leave deposits of sediment in drainage system. **Water with suspended solids concentrations or turbidity exceeding permit requirements shall not be disposed of in the drainage system.** Refer to Section 2.3.12 for additional discharge requirements. The Contractor will contain and direct all discharged water during well development and prevent erosion of surrounding areas.

This item includes, but is not limited to providing and constructing well discharge conveyance equipment (BMPs, holding tank, and piping) to safely and adequately convey well discharges from development and testing of the well to Dry Creek. Conveyance equipment should be sized to convey up to 1,200 gpm. A large Baker tank or similar holding tank shall be used to decant the water before discharge to the piping that will convey water to the creek. Tank should have the proper openings to pump off center of tank to avoid turbid water on tank bottom.

The Contractor shall comply with the National Pollutant Discharge Elimination System (NPDES) permit regarding disposing of solids and water generated during well development and testing. The contractor shall also comply with all water quality effluent limitations specified in the applicable NPDES permit.

NOTE: Illegal discharge is a Federal offense and maybe punishable by fines and or imprisonment. All solids and fluids shall be disposed of according to NPDES requirements.

Erosion within drainage features shall be minimized to the maximum extent practicable. Erosion and deposition of sediment downgradient, as identified by the Owner, shall be remedied after project completion if necessary, and approved by the Owner. Repair and/or removal of sediment shall be considered incidental to construction of well discharge conveyance equipment, and no additional payment will be made to the Contractor for ditch restoration work.

The well shall be sounded for total depth and the **Contractor shall remove sand and/or debris from the bottom of the well to the owner's satisfaction.**

2.3.11 Furnish and install pumping equipment for development and testing. Payment shall be made at the contract unit price per foot and shall be full compensation for furnishing all materials, labor, equipment, tools, and appurtenances necessary to complete the work. This item includes, but is not limited to the installation and removal of pumping equipment to develop and test the well.

The pump development and test pumping equipment shall include a submersible pump with a variable capacity up to 1,200 gpm from an estimated pumping water level of 120 feet and intake setting of 125 feet below ground level. The anticipated static water level in the well is 10 feet. The pump shall not have a check valve at the bottom so water is allowed to free-fall back through the column pipe when the pump is shut off. A 'Whisperwatt' or equivalent quiet running generator shall be used as the power source for the pump and furnished with a 110-volt outlet for use by the Owner during testing.

The discharge rate shall be measured during development and test pumping by an orifice weir as shown in Figure 7. The weir dimensions shall include appropriate diameter pipe and orifice plate for measuring the anticipated well flow. The discharge piping shall also include a new, easily operable and stable gate valve to control flow rates. All flow-rate monitoring equipment shall be approved by the Owner before installation.

The Contractor shall furnish and install a 1/4-inch threaded tap into the discharge line to allow attachment of a Rossum Sand Tester. The Owner will provide and operate the sand testing device for sand content measurement throughout the pump development and aquifer pumping test phases.

The Contractor shall furnish and install discharge piping of sufficient size and length to convey discharge water from the wellhead and pumping equipment into a Contractor-provided settling tank and then to Dry Creek approximately 1,200 feet west of the well. The Contractor shall install, maintain and remove all BMPs, protective liners or control devices, such as plastic sheeting and straw bales, necessary to minimize bank erosion to the creek. Refer to Section 2.3.10 for additional discharge requirements.

2.3.12 Well development - Pump method. Payment shall be made at the contract unit price per hour and shall be full compensation for furnishing all materials, labor, equipment, tools, and

appurtenances necessary to complete the work. This item includes, but is not limited to the development of the well using a test pump provided by the contractor.

Pump development will begin by slowly pumping the well at approximately 20% of the anticipated capacity, then surge, and backwash gently. Pumping rate will be gradually increased as the well shows improvement and the water clears until the maximum flow rate is reached. The Owner shall determine the maximum rate after consideration of the well drawdown and discharge characteristics. At periodic intervals (approximately 15 minutes), the pump shall be stopped and water in the pump column shall be allowed to surge back through the pump bowls and into the well.

Pump development shall continue until the following conditions have been met:

1. Sand content shall average no more than 5 mg/L for a complete pumping cycle of 2-hr duration when pumping at the design-discharge capacity.
2. No less than 10 measurements shall be taken at equal intervals to permit plotting of sand content as a function of time and production rate and to determine the average sand content for each cycle.
3. Development shall continue as long as the well's specific capacity continues to increase significantly.
4. The Owner shall determine when development is complete.

A total of 40 hours of pump development is anticipated. Contractor shall control and contain all drill cuttings and dispose of it off site at the Contractor's expense. **Disposal of drill cuttings and fluids to Dry Creek is prohibited.** Contractor shall properly dispose of all development water in accordance with applicable local, State, and Federal requirements and obtain necessary permits. The Contractor will contain and direct all discharged water during well development and prevent erosion of surrounding areas. The well shall be sounded for total depth and the **Contractor shall remove sand or debris from the bottom of the well.**

2.3.13 Operation and maintenance of pumping equipment for aquifer pumping tests.

Payment shall be made at the contract unit price per hour and shall be full compensation for furnishing all materials, labor, equipment, tools, and appurtenances necessary to complete the work. This item includes, but is not limited to the operation of installed pumping equipment for the performance of a 4-step pumping test and collection of water quality samples.

Following development operations the Contractor shall provide all materials, equipment, and labor to perform a complete pumping test of the well. The discharge rate shall be measured using an orifice weir and manometer as shown in Figure 7. The Owner shall direct test pumping with the anticipated pumping scenario to include but not be limited to the following:

Step Test - The step test will include a minimum of four different pumping rates between 200 and 800 gpm. Each rate will be pumped for an anticipated 120 minutes and minimum of 100 minutes. After step test completion, the well shall be allowed to recover to within 99% of the pre-testing static water level prior to removing test pump and equipment. No standby time will be paid during the recovery period.

Constant Discharge Test - The constant discharge test must be continuous without interruption for a minimum of 72 hours at a pumping rate to be determined by Owner. At the end of the 72-hour pumping period the pump may not be removed for a period of 36 hours or until approved by the Owner. If the constant discharge test is interrupted before 72 hours of continuous pumping have elapsed, the well shall be allowed to recover before test restart, for at least the amount of time the pump ran before failure. No payment shall be made for a constant discharge test that does not extend for a minimum of 72 hours or the time specified by the Owner, or during the recovery period following the constant discharge test.

Equipment installation for all tests shall be installed and ready to operate between 8:00-10:00 a.m. If test equipment is not ready to operate prior to 10:00 a.m. the scheduled test will be postponed until 8:00 a.m. the following morning with no bid item hourly rate or standby time being paid for the overnight delay. Actual measurements taken while testing for yield and drawdown will be the responsibility of the Owner. The Contractor shall maintain and operate all equipment and ensure its continuous uninterrupted operation as required.

After the pumping tests, the well shall be sounded for total depth and, if necessary, the Contractor shall remove sand or debris from the bottom of the well.

2.3.14 Well Spinner Survey. Payment shall be made at the contract unit price per each and shall be full compensation for furnishing all materials, labor, equipment, tools, and appurtenances necessary to complete the work. This item includes, but is not limited to, spinner survey to the full depth of the newly-constructed well. The Contractor shall install a nominal 3-inch diameter blank pipe to a depth of 130 feet, and a test pump capable of production in excess of 800 gpm installed to a depth not greater than 125 feet. The well shall have been pumped approximately 8-hours prior to conducting the spinner survey. In addition, the pump shall run up to 2-hours during the spinner survey. The owner is responsible to contract with a spinner survey contractor.

The Contractor shall remove the nominal 3-inch diameter blank pipe and test pump used for the spinner test at the end of the spinner survey.

2.3.15 Conduct video survey of completed well. Payment shall be made at the contract unit price per each and shall be full compensation for furnishing all materials, labor, equipment, tools, and appurtenances necessary to complete the work. This item includes, but is not limited to, video surveys to the full depth of the newly-constructed well.

The video surveying equipment shall include but not be limited to: a van capable of deploying a submersible camera unit or tools with recording capabilities and specifically designed and constructed for underwater operation and viewing of wells. The camera tool must have a bottom lens and light source for looking vertically down the well and shall record images in color. The camera shall also have a side-viewing camera and light source for viewing horizontally in the well. The side-viewing camera must be capable of providing images of the entire circumference of the well. Camera controls must be capable of switching instantaneously between the down-hole and side-views, with 360 degree rotation capability. The camera should also be equipped with a real time footage indicator on screen. The camera must record down-hole and side-view

still images at 10-foot intervals within the screened portion of the well. Two copies of the video survey record shall be provided to the Owner in DVD format. Numbers indicating the depth of the camera below the top of casing shall appear continuously and be legible. The Contractor shall inject potable water and/or a water clarifier into the well for a period of 12 to 24 hours prior to the video survey to provide greater clarity during the video survey. A Contractor experienced in video surveys such as Carson Pump of Carson City, Nevada, West Coast Well Logging Services of Rancho Cordova, California, or Owner-approved equal shall perform the video survey.

2.3.16 Well disinfection and well cap. Payment shall be made at the contract unit price lump sum and shall be full compensation for furnishing all materials, labor, equipment, tools, and appurtenances necessary to complete the work. This item includes, but is not limited to, disinfecting the well using a chlorine solution mixed in potable water after completion of brushing, air-lift development, and pump and surge development, and all down-hole surveys. The Contractor will use a disinfecting solution of such volume and strength that a concentration of at least 50 mg/l of available chlorine shall be obtained for the entire volume of water in the well. The disinfecting solution will be introduced into the well below the static water level through a tremie pipe and mixed throughout the water column by surge block or other mechanical action. After testing and approval of the well by the Owner, the well shall be capped with a 0.250-inch minimum thickness steel plate fully welded to the casing.

2.3.17 Temporary on-site waste facilities. Payment shall be made at the contract unit price per lump sum and shall be full compensation for delivery, cleaning, and rental of temporary on-site waste containment facilities.

2.3.18 Temporary on-site office during aquifer testing. Payment shall be made at the contract unit price per lump sum and shall be full compensation for delivery, cleaning, and rental of temporary office. The temporary office (small Class B, Class C or travel trailer RV) shall be rented from a licensed RV rental company and consist of a bed, sink, and bathroom at a minimum.

2.3.19

Standby hours at Owner's request. Payment shall be made at the contract unit price per hour and shall be full compensation for standby hours if requested by the Owner.

2.4 Army Aviation Well Drilling Construction Details

2.4.1 Drill/Install/Grout a 36-inch borehole and nominal 30-inch diameter surface conductor casing to a depth of 40 feet using the Mud Rotary method. Payment shall be made at the contract lump sum and shall be full compensation for furnishing all materials, labor, equipment, tools, and appurtenances necessary to complete the work. This item includes, but is not limited to, drilling, installation of one surface casing, and installation of 4 cubic yards of grout via tremie method from ground surface to 40 feet below land surface. The owner has determined the design of the conductor, but this design may change. Design changes will not interfere with the progress of the conductor installation. No payment shall be made for over-drilling as desired by the Contractor.

Surface conductors for the production wells shall consist of high-strength low alloy (HSLA, A606 type 4) steel free of any coating matter, and manufactured in accordance with applicable parts of ASTM Standard A 139 Grade B. The surface conductor casing shall be spiral welded, fabricated or mill-type. All pipe shall be in compliance with AWWA A100 Standards. The surface conductor casing shall have a wall thickness of 0.312 inches. Conductor casing wall thickness must meet or exceed requirements per *Regulations for Water Well and Related Drilling, Nevada Department of Conservation and Natural Resources, Division of Water Resources, revised October 24, 2014*).

2.4.2 Drill one 26-inch production borehole with the Flooded Reverse Circulation method.

Payment shall be made at the unit price per linear foot and shall be full compensation for furnishing all materials, labor, equipment, tools, and appurtenances necessary to complete the work. This item includes but is not limited to: drilling of one production boring using the flooded reverse circulation with water method. The 26-inch diameter production boring shall be drilled from the bottom of the surface conductor boring (40 feet) to total depth of 620 feet below land surface.

The owner has determined the design of the boring, but this design may change. Design changes will not interfere with the progress of the boring. No payment shall be made for over-drilling as desired by the Contractor.

2.4.3 Provide borehole geophysical survey. Payment shall be made at the unit price per each and shall be full compensation for furnishing all materials, labor, equipment, tools, and appurtenances necessary to complete the work. This item includes, but is not limited to providing spontaneous potential, resistivity, and caliper logging services.

The contractor shall be responsible for providing standard water well geophysical logs conducted by an Owner-approved, commercial logging services sub-contractor and performed in the presence of the Owner. The logs shall be presented in hard copy standard format and in electronic format on DVD. The logs shall consist of spontaneous potential, resistivity (point, short normal, long normal and lateral), and caliper and conducted once every 100-feet of drilled borehole. Any footage over 600 feet but less than 650 feet shall be logged as incidental to the unit price per each of this bid item. The entire borehole shall be logged as determined by the Owner.

2.4.4 Furnish/Install 10 linear feet of nominal 18-inch diameter 0.375-inch wall thickness 304L stainless steel sump from a depth of 600 feet to 610 feet. Payment shall be made at the contract unit price per linear foot and shall be full compensation for furnishing all materials, labor, equipment, tools, and appurtenances necessary to complete the work. This item includes, but is not limited to the supply and installation of one production well sump.

Production and sump casing shall have a pipe weight of 74.80 lbs/ft for the Army Aviation well. Casing shall be furnished in 20-foot lengths with 10-foot lengths to complete the casing program. Casing shall be manufactured with welded collars attached.

The stainless steel sump manufactured in conformance with ASTM A778. The sump shall be affixed to the bottom of the well screen using a welding collar. The well sump shall have a bull-nosed bottom constructed of 304L stainless steel and have a nominal diameter of 18 inches and a

minimum wall thickness of 0.375 inches or as recommended by the manufacturer for the total length of the casing and screen to be constructed, whichever is thickest. All blank casing (sump and bull-nose bottom) shall be of new, first quality materials and free of defects in workmanship and handling. No reject, sub-grade or limited-use pipe is acceptable.

The owner has determined the design of the production well sump, but this design may change. Design changes will not interfere with the progress of the production well sump installation.

2.4.5 Furnish/Install 160 linear feet of nominal 18-inch diameter 0.375-inch wall thickness 304L stainless steel Full Flo louvered screen placed at depths according to the well construction schedule shown in Figure 3. Payment shall be made at the contract unit price per linear foot and shall be full compensation for furnishing all materials, labor, equipment, tools, and appurtenances necessary to complete the work. This item includes, but is not limited to the supply and installation of 160 feet of production well screen.

The stainless steel screen shall be 0.090-inch slot for the nominal 18-inch diameter Army Aviation well. The screen shall be furnished in 40-foot lengths with 10-foot lengths to complete the screening program. Well shall be manufactured by Roscoe Moss Corporation (or approved equal).

Well screen shall be in conformance with ASTM A778. The screen sections shall be manufactured with the welded collars. Collars shall be the same thickness, physical, and chemical properties as the corresponding casing or screen section. Collars must be 5 inches in width, rolled to fit the outside diameter, and factory welded to one end of each section. The inside edge of the collars shall be free of sharp edges and burrs. Section ends shall be machined flat perpendicular to the axis of the casing or screen and shall not vary more than 0.010 inch at any point from a true plane at right angles to the axis of the casing or screen. Three (3) one and one sixteenth (1-1/16)-inch diameter inspection windows must be provided in each collar to ensure proper matching of the sections during the welding process to join sections.

Screen shall have a minimum wall thickness of 0.375 inches or as recommended by the manufacturer for the total length of the well casing and screen to be constructed, whichever is thickest. All screen shall be of new, first quality materials and free of defects in workmanship and handling. No reject, sub-grade or limited-use pipe is acceptable.

The owner has determined the design of the production well screen, but this design may change. Design changes will not interfere with the progress of the production well screen installation.

2.4.6 Furnish/Install 450 linear feet of nominal 18-inch diameter 0.375-inch wall thickness 304L stainless steel blank casing per the well construction schedule shown in Figure 3. Payment shall be made at the contract unit price per linear foot and shall be full compensation for furnishing all materials, labor, equipment, tools, and appurtenances necessary to complete the work. This item includes, but is not limited to the supply and installation of 450 feet of production well casing.

Production casing shall have a pipe weight of 74.80 lbs/ft for the Army Aviation well. Casing shall be furnished in 20-foot lengths with 10-foot lengths to complete the casing program. Casing shall

be manufactured with welded collars attached. The well casing shall be manufactured in conformance with ASTM A778. The well casing shall be affixed to the well screens using welding collars. The well casing shall consist of 304L stainless steel and have a nominal diameter of 18 inches and a minimum wall thickness of 0.375 inches or a recommended by the manufacturer for the total length of the well casing and screen to be constructed, whichever is thickest. All casing shall be of new, first quality materials and free of defects in workmanship and handling. No reject, sub-grade or limited-use pipe is acceptable.

The owner has determined the design of the production well casing, but this design may change. Design changes will not interfere with the progress of the production well casing.

Casing, screen, and sump shall be installed using methods approved by the Owner. The production well casing, well screen, and sump shall be suspended as a unit above the bottom of the hole at a sufficient distance to insure that no portion of the well is supported by the bottom of the borehole. The suspended casing unit shall be firmly secured at the surface until gravel and seal are permanently installed.

The well casing and screen shall have stainless steel centering guides approved by the Owner. The centering guides shall be installed at 40-foot intervals (four centering guides per interval) along the well screen and blank casing, or as otherwise approved by the Owner.

Welders completing field assembly of well casing, well screen, and sump shall be qualified in accordance with the latest revision of the section titled, Welding Procedures of the American Welding Society (AWS) Standard Qualification Procedure. All welds shall be continuous, watertight, fully penetrating fillet welds (joining sections and centering holes), and completed in accordance with AWS Standards and AWWA C206.

2.4.7 Water Level Gravel Feed Tube, Injection Tube, and Sounding Tubes – Contractor shall provide materials, equipment, and labor necessary to install one (1) nominal 3-inch gravel feed tube open to the top of the gravel pack; two (2) nominal 3-inch injection tubes; and one (1) nominal 2-inch stainless steel sounding tube. All tubes shall include water-tight caps above ground.

Contractor shall provide materials, equipment and labor necessary to install one nominal 3-inch ID stainless steel gravel feed tube to 304 feet, 4 feet below the bentonite seal, open to the top of the gravel pack to allow for future addition of gravel, if necessary. The gravel feed tube shall be constructed of nominal 3-inch diameter, 0.216-inch wall thickness, 304L stainless steel manufactured in conformance with ASTM A778. The gravel feed tube shall be encased in the sanitary grout seal and shall be open at the bottom to allow for placement of addition of gravel after the sanitary grout seal is installed. The gravel feed tube shall be equipped with a water tight cap.

Contractor shall provide materials, equipment and labor necessary to install two nominal 3-inch stainless steel injection tubes. Each injection tube will be 92 feet in length. The injection tube shall be constructed of nominal 3-inch diameter, 0.216-inch wall thickness, 304L stainless steel manufactured in conformance with ASTM A778. The injection tubes shall be encased in the sanitary grout seal. The bottom of each injection tubes will attach to the casing at a Roscoe Moss (or approved equal) entrance chamber boxes (Figures 4 and 5) positioned 90 feet below land

surface. The entrance chamber box shall be welded to the well casing according to manufacture specifications.

The one stainless steel sounding tube shall be 362 feet and constructed of nominal 2-inch diameter, 0.20-inch wall thickness, 304L stainless steel manufactured in conformance with ASTM A778. Stainless steel sounding tubes shall be attached to the outside of the well casing using stainless steel bands. The sounding tube shall be encased in the sanitary grout seal. The bottom of the injection tube will attach to the casing at a Roscoe Moss (or approved equal) entrance chamber box (Figures 4 and 5) positioned 360 feet below land surface. The entrance chamber box shall be welded to the well casing according to manufacture specifications.

The owner has determined the design of the gravel, injection, and sounding tubes but this design may change. Design changes will not interfere with the progress of the production well screen installation.

2.4.8 Furnish and install a 1/8-inch x 1/4-inch gravel pack in the well annulus for the via tremie pipe for the Army Aviation well. Payment shall be made at the contract unit price per cubic yard and shall be full compensation for furnishing all materials, labor, equipment, tools, and appurtenances necessary to complete the work. This item includes, but is not limited to the supply and installation of 23 cubic yards of gravel pack via tremie pipe from 300 feet to 610 feet below land surface. The owner has determined the design of the gravel pack, but this design may change. Design changes will not interfere with the progress of the gravel pack installation.

Drilling fluid will be closely monitored throughout the drilling process to minimize borehole wall cake development prior to placement of gravel pack. Gravel pack shall be placed by tremie pipe in the annulus between well casing and borehole sidewall. Gravel pack shall be composed of washed, sound, durable, well-rounded particles containing no silt, clay, organic matter or deleterious materials. Gravel pack shall meet specifications as per AWWA A100-06. Gravel pack shall be delivered and stored at the drill site in protective bags. Gravel pack shall be manufactured by a company specializing in water well gravel pack such as SRI Supreme or approved equal. The Contractor shall supply Owner with an invoice stating quantity, gradation, and well screen compatibility for the gravel pack delivered to the drill site.

The Contractor shall determine when conditions are satisfactory for gravel pack placement. Gravel pack shall be placed through a tremie pipe installed to the depth specified by the Owner. Only potable water and disinfectant shall be mixed with the gravel pack during placement. Shoveling or end-dumping with a loader of gravel-pack directly into the borehole is not permitted. The gravel pack shall be disinfected by adding a minimum of twenty (20) pounds of 65-70%-granulated calcium hypochlorite to the gravel pack during placement. The calcium hypochlorite shall be evenly distributed throughout the gravel pack. The gravel tremie pipe shall be removed after placement.

The Contractor shall place the gravel in the annulus without bridging, such that there are no voids. Bridging of gravel pack shall be assumed if the volume of gravel-pack placed is less than 90% of the calculated annular volume for the total borehole depth. If bridging is identified by the above calculation, the bridging shall be corrected at the contractor's expense without damage

to the casing, screen, sump, or borehole, or drill a new borehole and install new casing, screen, and sump to the satisfaction of the Owner. If the Contractor chooses to drill a new well, he shall be responsible for all costs associated with properly drilling the new well and properly abandoning the failed well.

2.4.9 Furnish and install bentonite pellet and sanitary seal to surface via tremie pipe.

Payment shall be made at the contract unit price per cubic yard and shall be full compensation for furnishing all materials, labor, equipment, tools, and appurtenances necessary to complete the work. This item includes, but is not limited to the supply and installation of 0.5 cubic yards of bentonite pellets above the gravel pack from 296 to 300 feet, and 22 cubic yards of cement grout seal via tremie pipe from land surface to 296 feet below land surface. The owner has determined the design of the sanitary seal, but this design may change. Design changes will not interfere with the progress of the sanitary seal installation.

The bentonite pellets and cement grout shall be placed by positive displacement through a tremie pipe or by the Haliburton method. Cement grout shall be placed within 30 minutes of mixing. The cement grout slurry shall consist of equal parts of cement and sand with 6 gallons of clean water for one 94-pound sack of Portland type C cement (or as defined in NAC 534.060 of *Regulations for Water Well and Related Drilling, Nevada Department of Conservation and Natural Resources, Division of Water Resources, revised 2014*). The slurry shall be thoroughly mixed and free of lumps and stones and put through a protective strainer before pumping into the well. The final mix shall produce a slurry weight of 15.6 pounds per gallon. Calcium chloride, bentonite or other additives are not allowed. The slurry shall be placed in one continuous operation once the process begins. The sanitary seal shall be left undisturbed for a minimum of 24 hours after the final batch or lift of slurry has been placed. No standby time shall be paid during this period.

The Contractor shall provide an invoice stating the quantity of slurry placed into the annulus.

2.4.10 Well Development - Mechanical method. Payment shall be made at the contract unit price per hour and shall be full compensation for furnishing all materials, labor, equipment, tools, and appurtenances necessary to complete the work. This item includes, but is not limited to the development of the well using the dual swab and simultaneous airlift development method.

Contractor shall provide all materials, equipment and labor necessary to develop the well. Well development shall progress in three phases:

4. Predevelopment
5. Mechanical Development
6. Pump Development

Predevelopment shall occur during the drilling of the well by the Contractor using proper drilling additives (those essential for flooded reverse circulation drilling), as specified the manufacturer and above. Contractor shall minimize the use of drilling additives. Drilling fluids shall be conditioned (thinned), if necessary, to a minimum before installation of casing and gravel-pack to ensure ease of additive removal during subsequent development phases.

Mechanical development shall begin with the dual swab and simultaneous airlift development method. Surge blocks shall be snug-fitting double-flanged with perforated pipe and fabricated according to the diagram shown in Figure 6. Dual swab and simultaneous airlift development shall proceed by vigorously raising and lowering the drill pipe starting at the top of the screen to minimize the risk of sand locking the swabs. Surge and airlift development shall follow the procedures described on pages 514 and 515 of *Groundwater and Wells, Second Edition, Fletcher Driscoll, Johnson Filtration Systems*. The compressor for development shall have a minimum capacity to unload 570 feet of water from an airline setting of 600 feet below top of casing. The compressor shall produce a minimum air volume of 750 cubic feet per minute at 300 psi. Development by surging shall begin at the bottom of the screen and shall gradually move upward to the top of the well.

If necessary, the Contractor will use a dispersing agent during airlift development to facilitate the breakdown of drilling additives (if used) remaining from drilling operations. **Use of phosphate products such as sodium acid pyrophosphate (SAPP) during well development is not allowed.** The Contractor shall use a dispersing agent as recommended by the manufacturer for wells of this diameter, depth and formations penetrated. Documentation of application volumes, ratios and method of introduction shall be submitted to the Owner prior to product use. The dispersant will be mixed thoroughly, injected into the well, swabbed into the well from the bottom up after injection, and then allowed to remain undisturbed overnight. No stand by time will be paid during this period. Mechanical well development by double-swab will continue at ten (10)-foot intervals until dispersant treatment is complete. Upon completion of dispersant treatment, mechanical well development by surging will continue at ten (10)-foot intervals until, in the opinion of the Owner, well development is complete. A total of 65 hours of mechanical and airlift development is anticipated.

Contractor shall control and contain all drill cuttings and fluid. Contractor shall properly dispose of all development water in accordance with applicable local, State, and Federal requirements and obtain necessary permits. The Contractor will contain and direct all discharged water during well development and prevent erosion of surrounding areas.

Payment shall be made at the contract unit price lump sum and shall be full compensation for furnishing all materials, labor, equipment, tools, and appurtenances necessary to complete the work. This item includes, but is not limited to providing and constructing well discharge conveyance equipment (BMPs, piping, and holding tank) to safely and adequately convey well discharges away from the well site. Conveyance equipment should be sized to convey 2500 gpm approximately 1,000 feet. A large Baker tank or similar holding tank shall be used to decant the water prior to discharge to conveyance piping. The tank should have the proper openings to pump off center of tank to avoid turbid water on tank bottom

The Contractor shall comply with the National Pollutant Discharge Elimination System (NPDES) permit regarding disposing of solids and water generated during well redevelopment, and well testing. The contractor must adhere to all water quality effluent limitations specified in the applicable NPDES permit.

NOTE: Illegal discharge is a Federal offense and maybe punishable by fines and or

imprisonment. All solids and fluids shall be disposed of according to NPDES requirements.

Erosion within drainage features shall be minimized to the maximum extent practicable. Erosion and deposition of sediment downgradient, as identified by the Owner, shall be remedied after project completion if necessary, and approved by the Owner. Repair and/or removal of sediment shall be considered incidental to construction of well discharge conveyance equipment, and no additional payment will be made to the Contractor for ditch restoration work.

The well shall be sounded for total depth and the **Contractor shall remove sand or debris from the bottom of the well to the Owner's satisfaction.**

2.4.11 Furnish and Install Pumping Equipment for Development and Testing. Payment shall be made at the contract unit price per foot and shall be full compensation for furnishing all materials, labor, equipment, tools, and appurtenances necessary to complete the work. This item includes, but is not limited to the installation and removal of pumping equipment to develop and test the well.

The pump development and test pumping equipment shall include a submersible pump with a variable capacity up to 2500 gpm from an estimated pumping water level of 280 feet and intake setting of 290 feet below ground level. The anticipated static water level in the well is 70 feet. The pump shall not have a check valve at the bottom so water is allowed to free-fall back through the column pipe when the pump is shut off. A 'Whisperwatt' or equivalent quiet running generator shall be used as the power source for the pump and furnished with a 110-volt outlet for use by the Owner during testing.

The discharge rate shall be measured during development and test pumping by an orifice as shown in Figure 7. The weir dimensions shall include appropriate diameter pipe and orifice plate for measuring the anticipated well flow. The discharge piping shall also include a new, easily operable and stable gate valve to control flow rates. All flow-rate monitoring equipment shall be approved by the Owner before installation.

The Contractor shall furnish and install a 1/4-inch threaded tap into the discharge line to allow attachment of a Rossum Sand Tester. The Owner will provide and operate the sand testing device for sand content measurement throughout the pump development and aquifer pumping test phases.

The Contractor shall furnish and install a settling tank and approximately 1,000 feet of discharge piping of sufficient size to convey discharge water from the wellhead and pumping equipment. The Contractor shall install, maintain and remove all BMPs, protective liners or control devices, such as plastic sheeting and straw bales, necessary to minimize ground erosion.

2.4.12 Well development - Pump method. Payment shall be made at the contract unit price per hour and shall be full compensation for furnishing all materials, labor, equipment, tools, and appurtenances necessary to complete the work. This item includes, but is not limited to the development of the well using a test pump provided by the contractor.

Pump development will begin by slowly pumping the well at approximately 20% of the anticipated capacity, then surge, and backwash gently. Pumping rate will be gradually increased as the well shows improvement and the water clears until the maximum flow rate is reached. The Owner shall determine the maximum rate after consideration of the well drawdown and discharge characteristics. At periodic intervals (approximately 15 minutes), the pump shall be stopped and water in the pump column shall be allowed to surge back through the pump bowls and into the well.

Pump development shall continue until the following conditions have been met:

5. Sand content shall average no more than 5 mg/L for a complete pumping cycle of 2-hr duration when pumping at the design-discharge capacity.
6. No less than 10 measurements shall be taken at equal intervals to permit plotting of sand content as a function of time and production rate and to determine the average sand content for each cycle.
7. Development shall continue as long as the well's specific capacity continues to increase significantly.
8. The Owner shall determine when development is complete.

A total of 65 hours of pump development is anticipated. Contractor shall control and contain all drilling mud and dispose of it off site at the Contractor's expense. **Disposal of drilling fluid at the well site is prohibited.** Contractor shall properly dispose of all development water in accordance with applicable local, State, and Federal requirements and obtain necessary permits. The Contractor will contain and direct all discharged water during well development and prevent erosion of surrounding areas. The well shall be sounded for total depth and the **Contractor shall remove sand or debris from the bottom of the well.**

2.4.13 Operation and Maintenance of Pumping Equipment for Aquifer Pumping Tests.

Payment shall be made at the contract unit price per hour and shall be full compensation for furnishing all materials, labor, equipment, tools, and appurtenances necessary to complete the work. This item includes, but is not limited to the operation of installed pumping equipment for the performance of a 4-step pumping test and collection of water quality samples.

Following development operations the Contractor shall provide all materials, equipment, and labor to perform a complete pumping test of the well. The discharge rate shall be measured using an orifice weir and manometer as shown in Figure 7. The Owner shall direct test pumping with the anticipated pumping scenario to include but not be limited to the following:

Step Test - The step test will include a minimum of four different pumping rates between 1000 and 2500 gpm. Each rate will be pumped for an anticipated 120 minutes and minimum of 100 minutes. After step test completion, the well shall be allowed to recover to within 99% of the pre-testing static water level prior to removing test pump and equipment. No standby time will be paid during the recovery period.

Constant Discharge Test - The constant discharge test must be continuous without interruption for a minimum of 72 hours at a pumping rate to be determined by Owner. At the end of the 72-hour pumping period the pump may not be removed for a period of 36 hours or until approved by the Owner. If the constant discharge test is interrupted before 72 hours of continuous pumping have

elapsed, the well shall be allowed to recover before test restart, for at least the amount of time the pump ran before failure. No payment shall be made for a constant discharge test that does not extend for a minimum of 72 hours or the time specified by the Owner, or during the recovery period following the constant discharge test.

Equipment installation for all tests shall be installed and ready to operate between 8:00-10:00 a.m. If test equipment is not ready to operate prior to 10:00 a.m. the scheduled test will be postponed until 8:00 a.m. the following morning with no bid item hourly rate or standby time being paid for the overnight delay. Actual measurements taken while testing for yield and drawdown will be the responsibility of the Owner. The Contractor shall maintain and operate all equipment and ensure its continuous uninterrupted operation as required.

After pumping tests, the well shall be sounded for total depth and, if necessary, the Contractor shall remove sand or debris from the bottom of the well.

2.4.14 Well Spinner Survey. Payment shall be made at the contract unit price per each and shall be full compensation for furnishing all materials, labor, equipment, tools, and appurtenances necessary to complete the work. This item includes, but is not limited to, the spinner survey to the full depth of the newly-constructed well. The Contractor shall install a nominal 3-inch diameter blank pipe to a depth of 310 feet to perform a spinner survey, and a test pump capable of production in excess of 2500 gpm installed to a depth not greater than 300 feet. The well shall have been pumped approximately 8-hours prior to conducting the spinner survey. In addition, the pump shall run up to 2-hours during the spinner survey. The Owner is responsible to contract with a spinner survey contractor.

The Contractor shall remove the nominal 3-inch diameter blank pipe and test pump used for the spinner test at the end of the spinner survey.

2.4.15 Conduct video survey of completed well. Payment shall be made at the contract unit price per each and shall be full compensation for furnishing all materials, labor, equipment, tools, and appurtenances necessary to complete the work. This item includes, but is not limited to, video surveys to the full depth of the newly-constructed well.

The video surveying equipment shall include but not be limited to: a van capable of deploying a submersible camera unit or tools with recording capabilities and specifically designed and constructed for underwater operation and viewing of wells. The camera tool must have a bottom lens and light source for looking vertically down the well and shall record images in color. The camera shall also have a side-viewing camera and light source for viewing horizontally in the well. The side-viewing camera must be capable of providing images of the entire circumference of the well. Camera controls must be capable of switching instantaneously between the down-hole and side-views, with 360 degree rotation capability. The camera should also be equipped with a real time footage indicator on screen. The camera must record down-hole and side-view still images at 10-foot intervals within the screened portion of the well. Two copies of the video survey record shall be provided to the Owner in DVD format. Numbers indicating the depth of the camera below the top of casing shall appear continuously and be legible. The Contractor shall inject potable water and/or a water clarifier into the well for a period of 12 to 24 hours prior

to the video survey to provide greater clarity during the video survey. A Contractor experienced in video surveys such as Carson Pump of Carson City, Nevada, West Coast Well Logging Services of Rancho Cordova, California, or Owner-approved equal shall perform the video survey.

2.4.16 Well disinfection and well cap. Payment shall be made at the contract unit price lump sum and shall be full compensation for furnishing all materials, labor, equipment, tools, and appurtenances necessary to complete the work. This item includes, but is not limited to, disinfecting the well using a chlorine solution mixed in potable water after completion of brushing, air-lift development, and pump and surge development, and all down-hole surveys. The Contractor will use a disinfecting solution of such volume and strength that a concentration of at least 50 mg/l of available chlorine shall be obtained for the entire volume of water in the well. The disinfecting solution will be introduced into the well below the static water level through a tremie pipe and mixed throughout the water column by surge block or other mechanical action. After testing and approval of the well by the Owner, the well shall be capped with a 0.250-inch minimum thickness steel plate fully welded to the casing.

2.4.17 Temporary on-site waste facilities. Payment shall be made at the contract unit price per lump sum and shall be full compensation for delivery, cleaning, and rental of temporary on-site waste containment facilities.

2.4.18 Temporary office during aquifer testing. Payment shall be made at the contract unit price per lump sum and shall be full compensation for delivery, cleaning, and rental of temporary office. The temporary office (small Class B, Class C or travel trailer RV) shall be rented from a licensed RV rental company and consist of a bed, sink, and bathroom at a minimum.

2.4.19 Standby hours at Owner's request. Payment shall be made at the contract unit price per hour and shall be full compensation for standby hours if requested by the Owner.

3. PLUMBNESS AND ALIGNMENT

The Contractor shall guarantee the completed well is sufficiently straight and plumb to permit an unencumbered installation and operation of pumping equipment. The Contractor shall conduct a gyroscopic deviation survey of the total depth of the well to verify plumbness and alignment according to AWWA A100-97. The gyroscopic deviation tool shall record the measured depth, direction the casing is traveling, and the angle or inclination of the casing. The survey shall be recorded on DVD format with readings every 10 feet. The information shall be analyzed and plotted with vertical and horizontal projection prints in a clear and readable format and submitted as a PDF. The gyroscopic deviation survey shall be performed by a Contractor experienced in such surveys such as Welenco of Bakersfield, California, or approved equal.

The deviation from plumbness shall not exceed two-thirds (2/3) the well's inside diameter per 100 feet. Failure to pass the gyroscopic deviation survey plumbness and alignment test shall result in rejection of the subject well. The well shall be rejected if deviations do not meet the alignment requirements. No payment shall be made for any portion of the contract if the Owner rejects the well. Should the well fail to pass the plumbness and alignment test and have to be

abandoned, the Contractor shall be responsible for proper abandonment of the well at no cost to the Owner.

D. MEASUREMENT AND PAYMENT

Payment for work covered by this specification and the associated bid item in the Proposal-Schedule of Items and Prices will be as approved by the Owner. Payment will be based on the price negotiated for the additional work, or on a cost accounting basis.

Payment will be made only for additional work performed and approved by the Owner. Depending upon the amount of additional work authorized and completed at the close of the Contract, the amount bid may be entirely, partially, or not used.

END OF SECTION

FIGURES

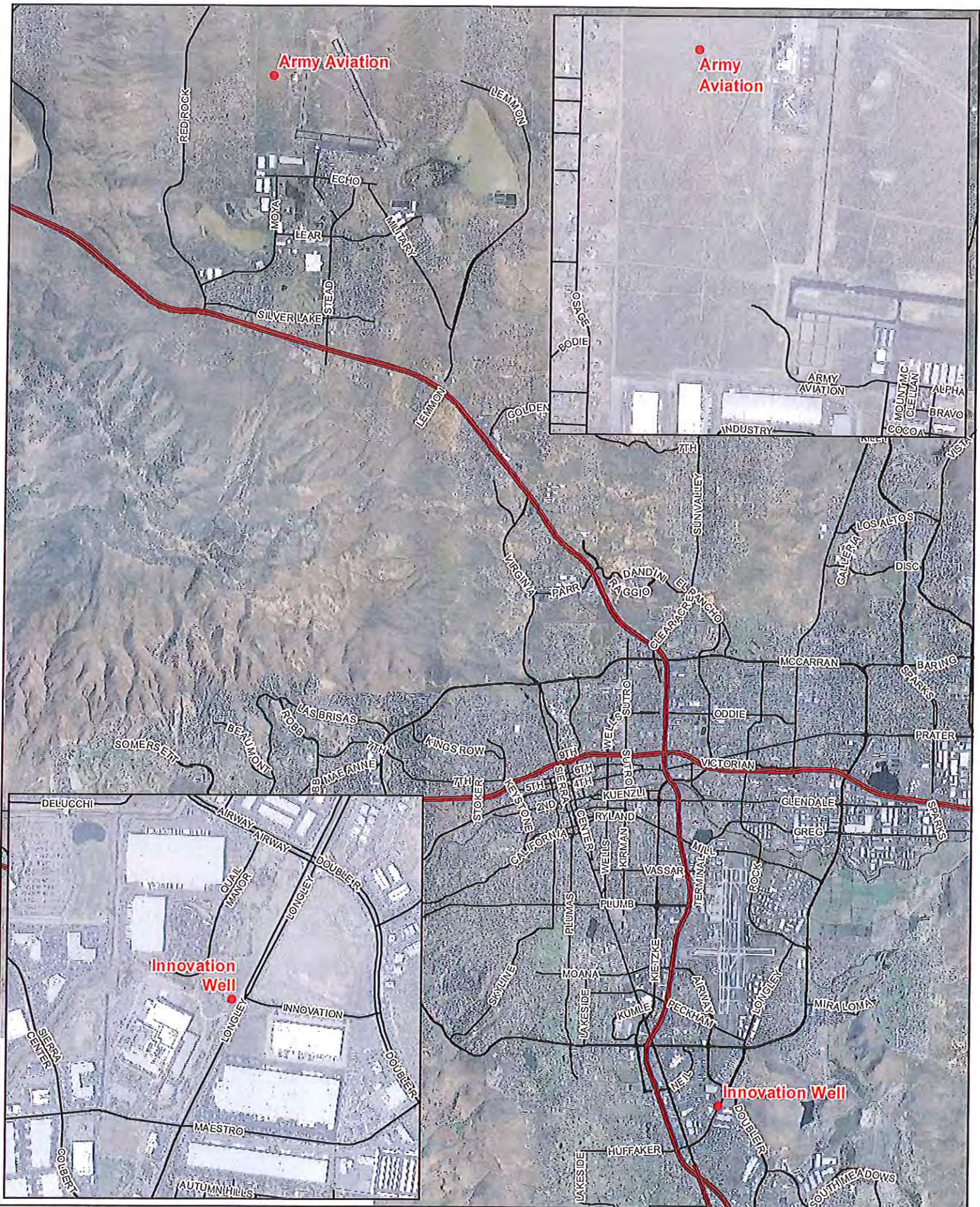

C:\Users\james\Documents\Hydro\Science\groundwater files\Well Rehabilitation\Innovation-Longley Well Materials Diagram.dwg
 Jan 15, 2015 8:02am

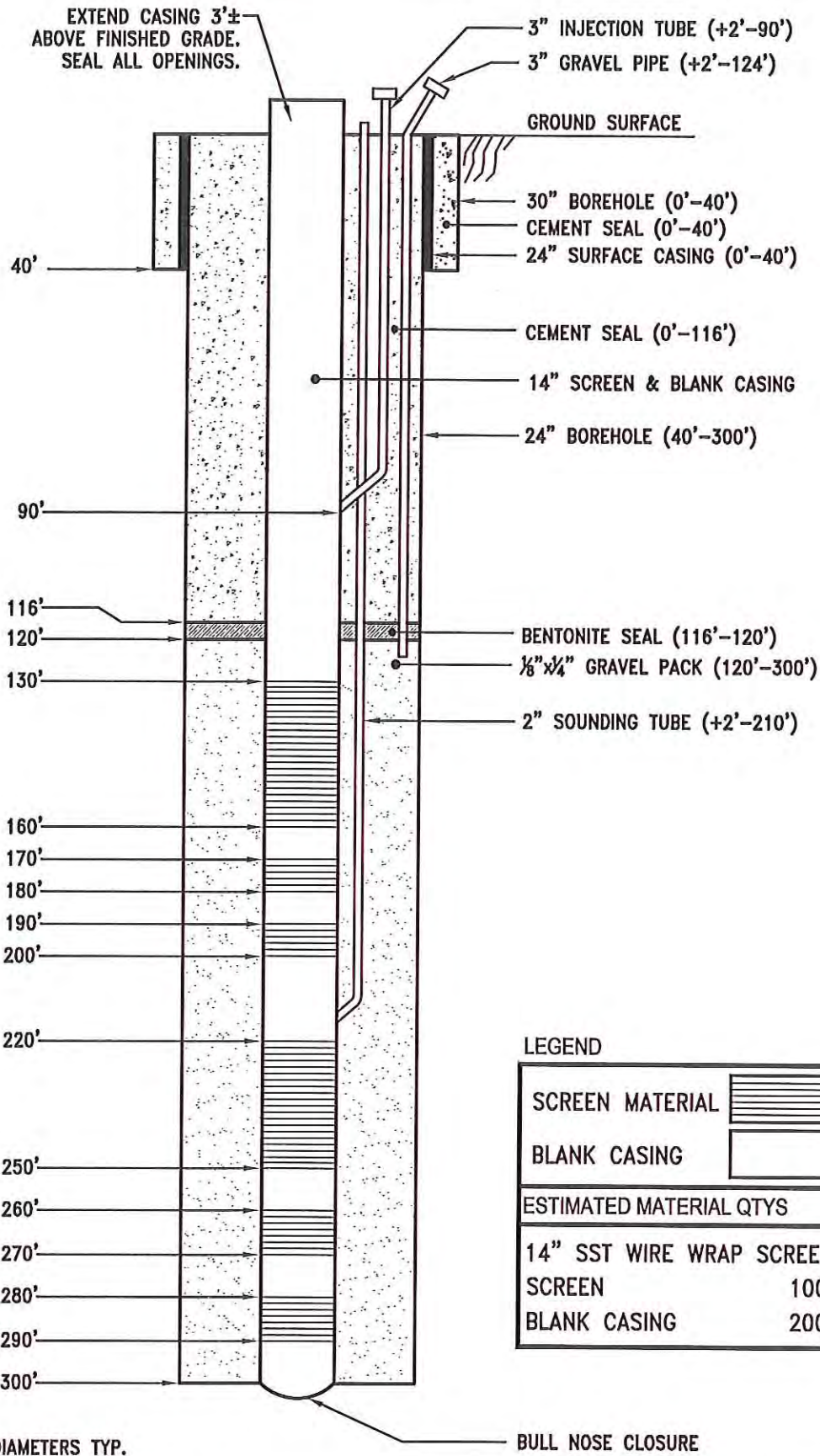

* NOMINAL DIAMETERS TYP.

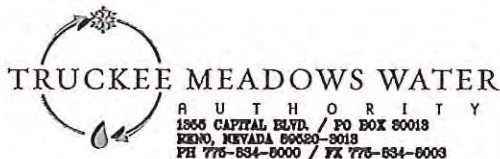

**INNOVATION PRODUCTION WELL
CONSTRUCTION MATERIALS DIAGRAM**

DATE: JUNE 2015

DRAWN BY: TK

WORK ORDER #:

SCALE: NTS

FIGURE

2

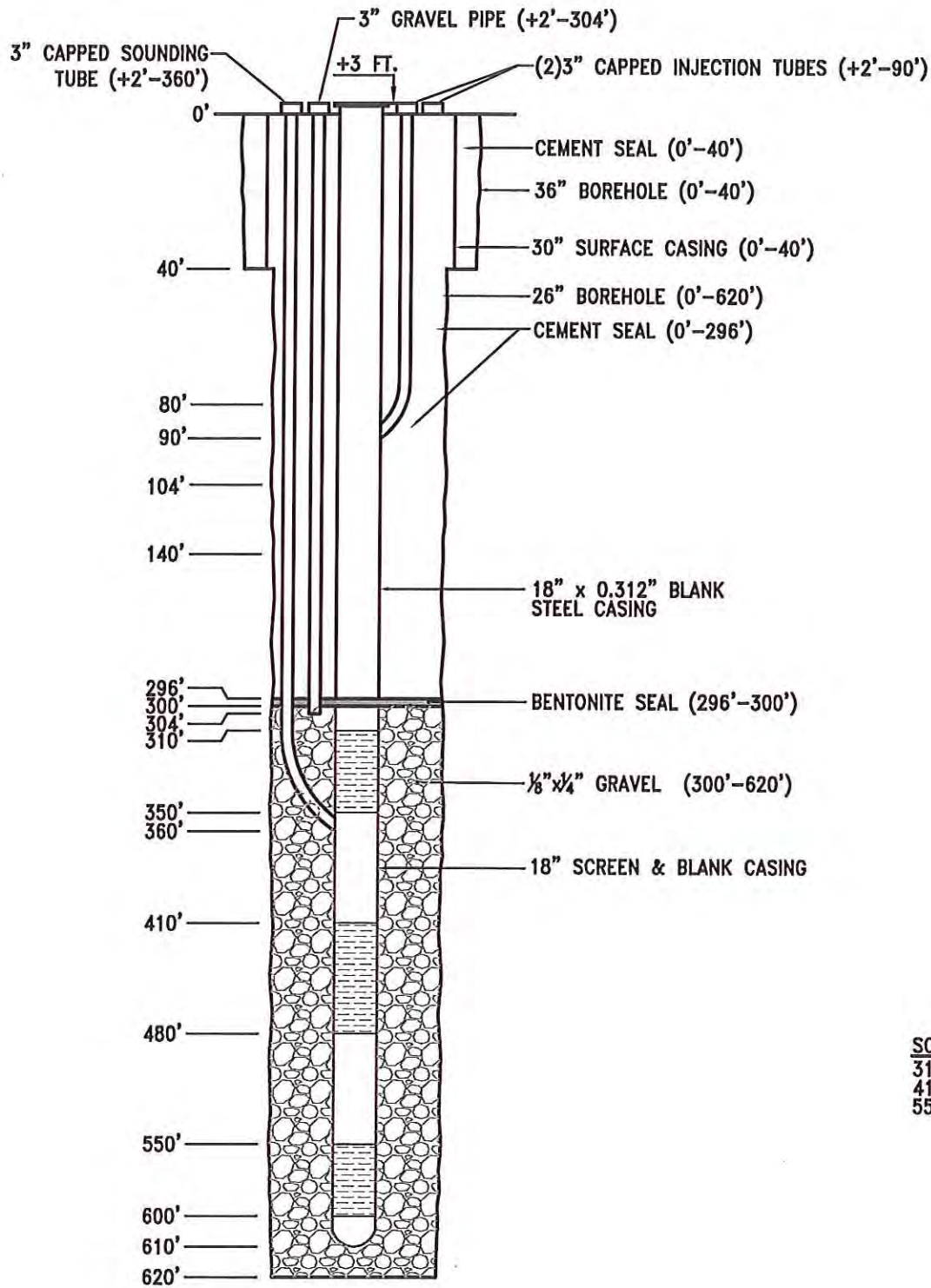

SCREEN SECTIONS			
310'	-	350'	40'
410'	-	480'	70'
550'	-	600'	50'
			<u>160'</u>

* NOMINAL DIAMETERS TYP.

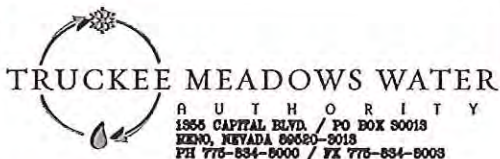

**ARMY AVIATION PRODUCTION WELL
CONSTRUCTION MATERIALS DIAGRAM**

DATE: MAY 2015

DRAWN BY: TK

WORK ORDER #:

SCALE: NTS

FIGURE

3

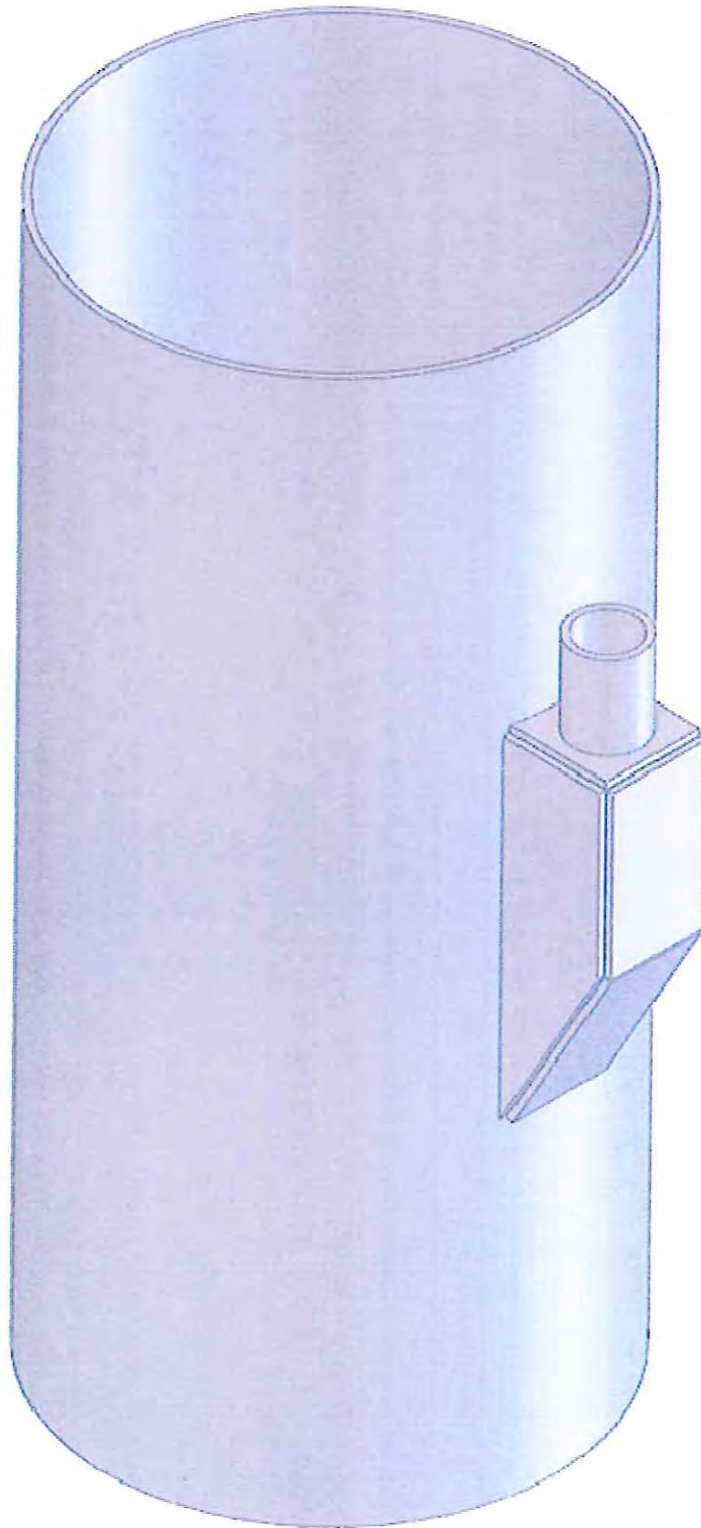

J:\NaturalResources\HydrologicScience\groundwater files\Well Siting and Drilling\Standard Diagrams & Figures\Tube Entrance Chamber Box.dwg
 Jun 09, 2015 - 10:27am

TRUCKEE MEADOWS WATER
 AUTHORITY
 1355 CAPITAL BLVD. / PO BOX 90013
 RENO, NEVADA 89520-5013
 PH 775-834-8000 / FX 775-834-8003

TUBE ENTRANCE CHAMBER BOX

DATE:	JUNE 2015
DRAWN BY:	TK
WORK ORDER #:	NA
SCALE:	NTS

FIGURE

4

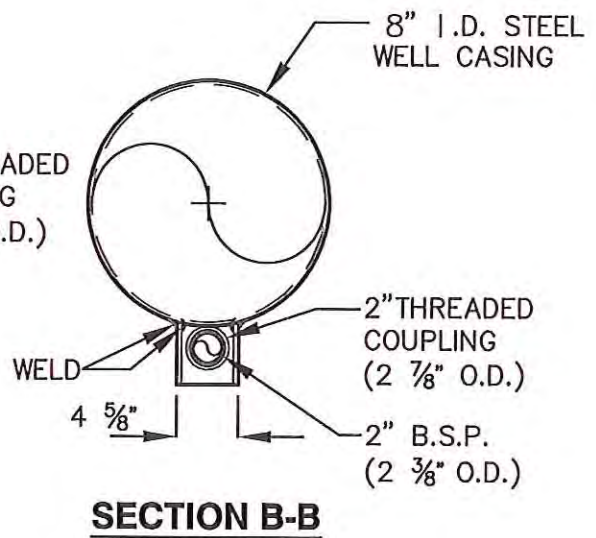
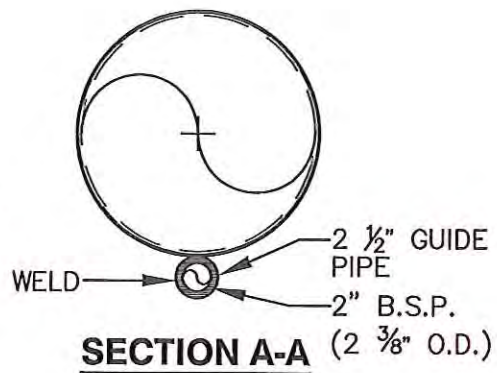
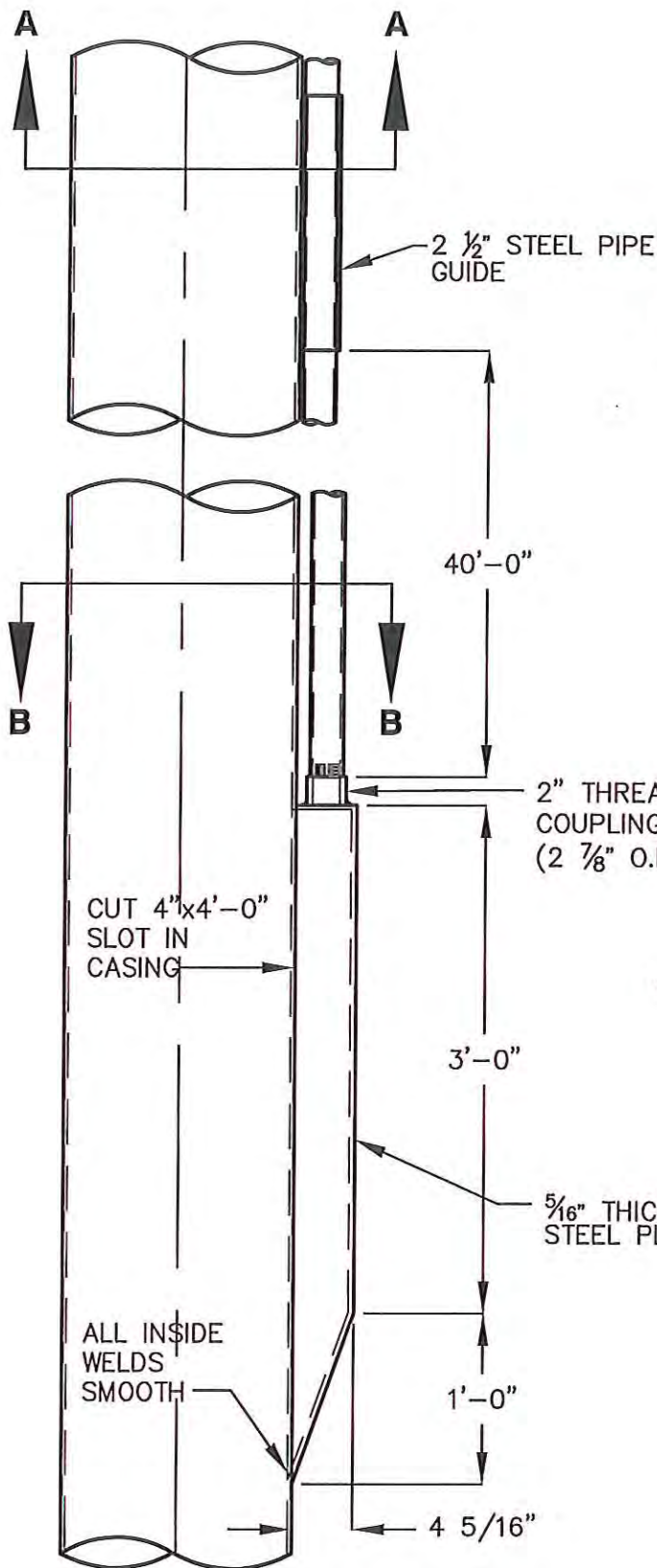

J:\NaturalResources\Hydrology\Sciences\groundwater files\Well Siting and Drilling\Standard Diagrams & Figures\Sounding Tube.dwg
 Jun 02, 2015 - 10:20am

J:\NaturalResources\HydrologicSciences\groundwater files\Well Siting and Drilling\Standard Diagrams & Figures\Development Tool Diagram.dwg
 Jun 09, 2015 - 9:37am

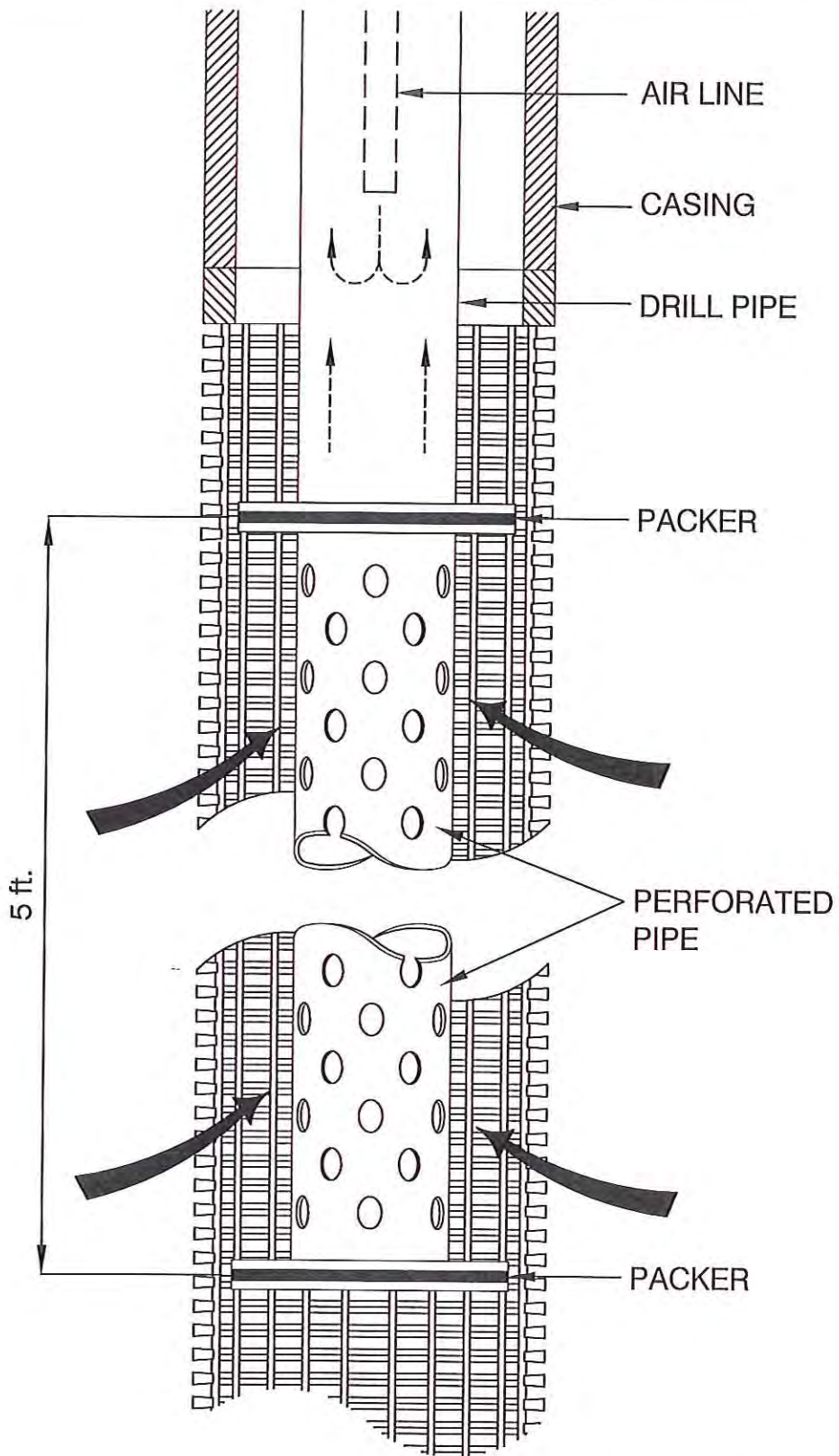

Groundwater and Wells, Johnson Filtration Systems



TRUCKEE MEADOWS WATER
 R U T H O R I T Y
 1335 CAPITAL BLVD. / PO BOX 30013
 RENO, NEVADA 89520-3013
 PH 775-894-8000 / FX 775-894-8003

ORIFICE WEIR DIAGRAM

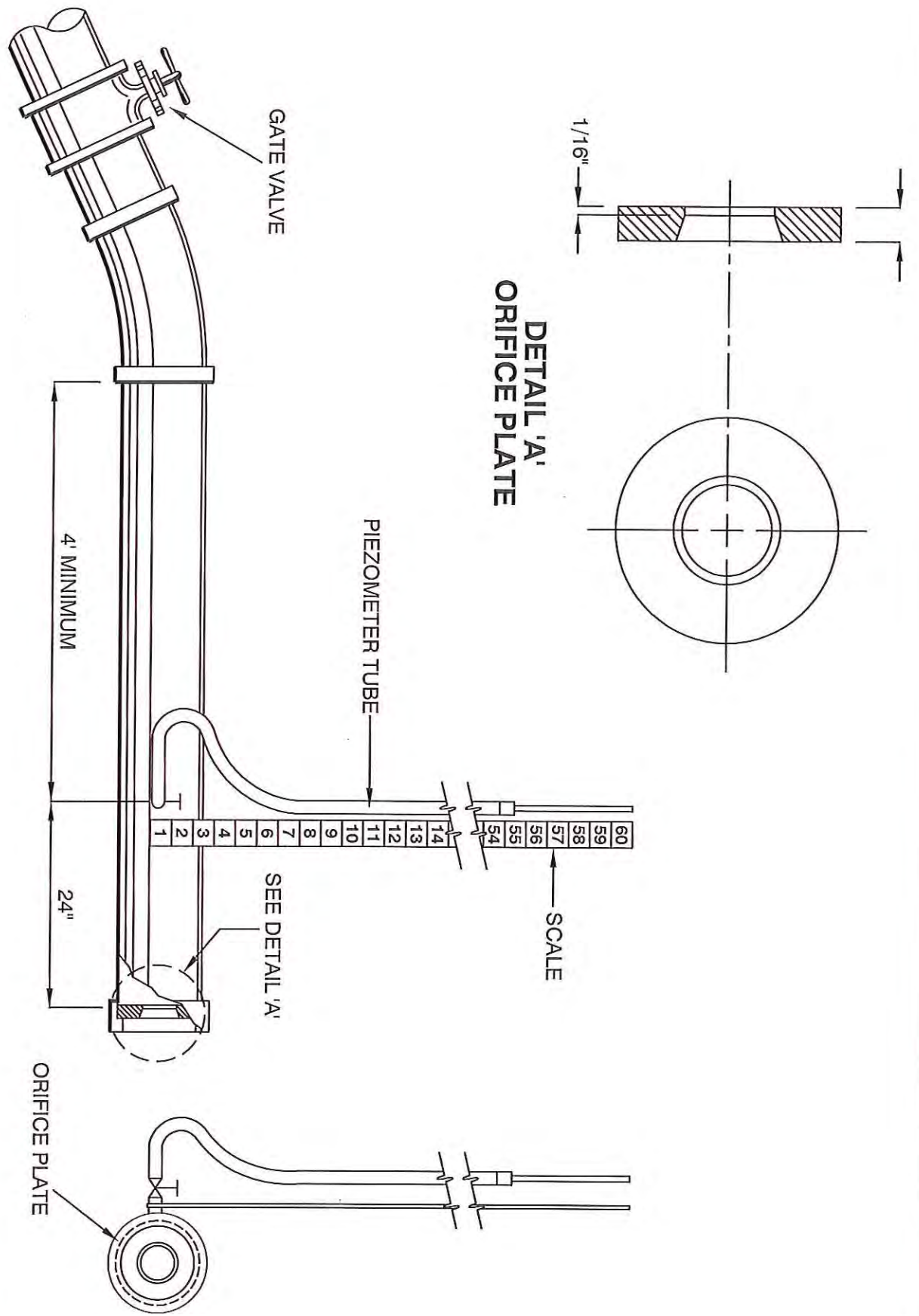

DATE:	JUNE 2015
DRAWN BY:	TK
WORK ORDER #:	NA
SCALE:	NTS

FIGURE