

PLAN VIEW

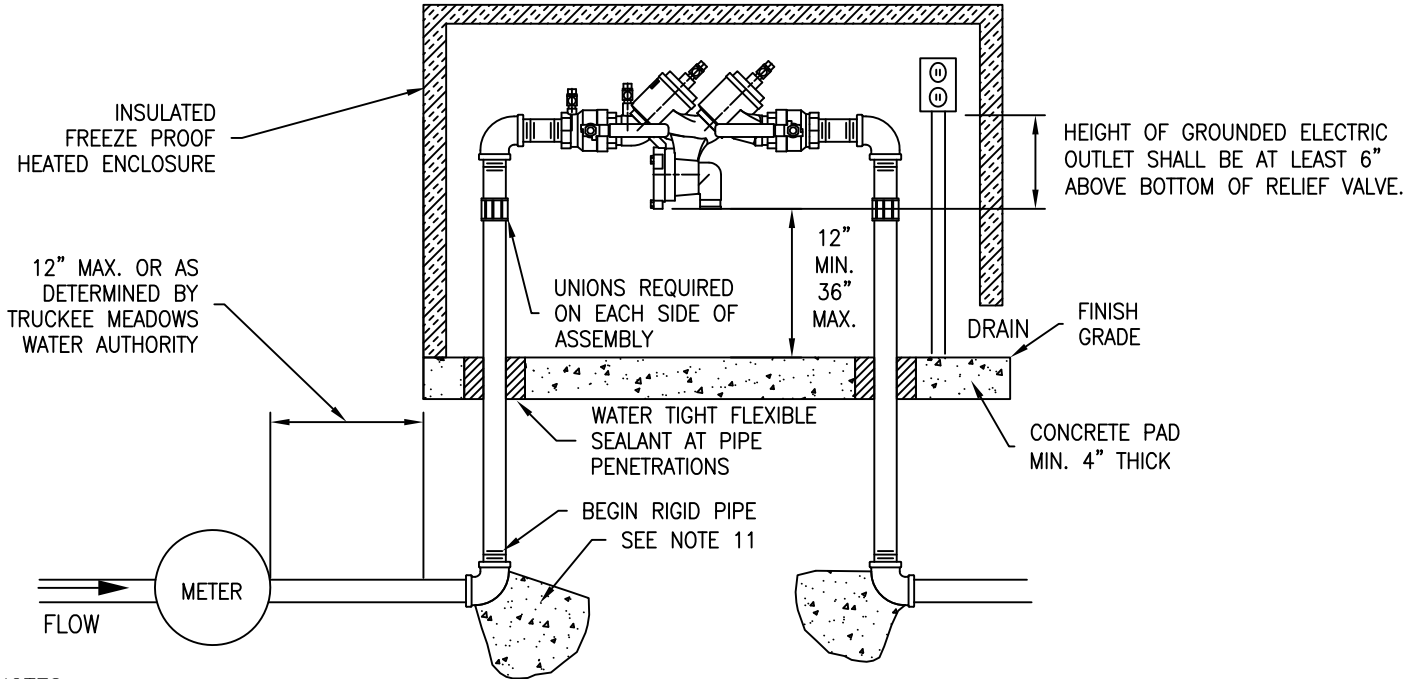

NOTES:

1. ASSEMBLY SHALL BE A USC APPROVED LEAD FREE DEVICE.
2. THE RP SHALL BE INSTALLED ABOVE GRADE.
3. GROUNDED ELECTRIC SUPPLY SHALL BE A MINIMUM OF 6" ABOVE BOTTOM OF RELIEF VALVE AND STUBBED TO THE OUTSIDE.
4. NO STOP AND WASTE VALVES.
5. FREEZE PROOF INSULATED BOX AND 1 SOURCE OF HEAT ARE REQUIRED. 2 SOURCES OF HEAT ARE STRONGLY RECOMMENDED.
6. INSULATED BOX SHALL SWING CLEAR OF ASSEMBLY TO PROVIDE CLEARANCES SHOWN OR INSULATED BOX SHALL BE SIZED TO PROVIDE CLEARANCES SHOWN.
7. SPRING LOADED LID REQUIRED ON LARGE BOXES.
8. THERMAL EXPANSION PROTECTION IS REQUIRED IN ANY DOMESTIC WATER SUPPLY SYSTEM THAT IS DOWNSTREAM FROM A BACKFLOW PREVENTION DEVICE. REFERENCE: UNIFORM PLUMBING CODE & NAC 445A.67235.
9. INSPECTION BY TMWA BACKFLOW PREVENTION GROUP PERSONNEL REQUIRED BEFORE METER IS SET OR SERVICE IS ACTIVATED.
10. IF INITIAL TEST DONE BY TMWA FIELD PERSONNEL FAILS, RETESTING OF BACKFLOW ASSEMBLY IS REQUIRED WITHIN 7 DAYS AFTER METER IS SET OR SERVICE ACTIVATION. COPY OF TEST RESULTS TO BE FORWARDED TO TMWA BACKFLOW PREVENTION GROUP BY A CERTIFIED ASSEMBLY TESTER WITHIN THAT SAME TIMEFRAME.
11. MINIMUM DIMENSIONS FOR THE THRUST BLOCK BEARING AREA FOR PIPE 2" AND SMALLER SHALL BE 8" X 8" AND 12" IN DEPTH. ALL OTHER SIZES TO BE DETERMINED BY ENGINEER.

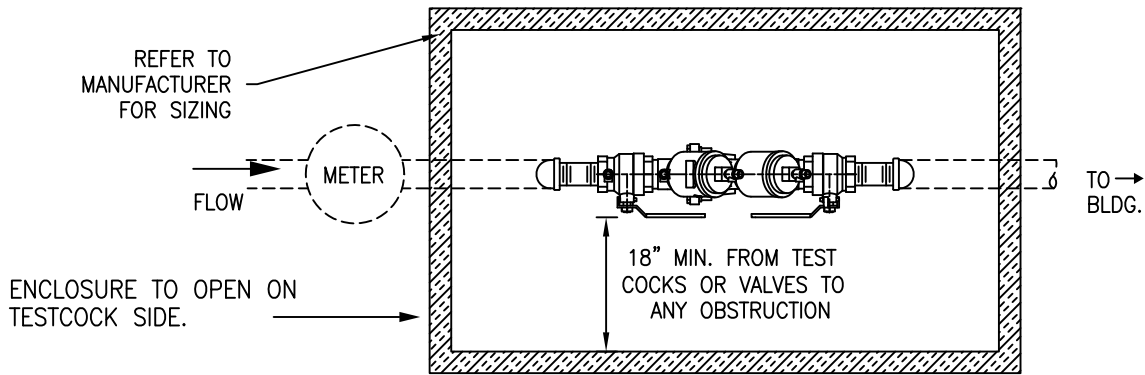

DATE

7/2001

REV

9/2016

APPENDIX 10A
BACKFLOW PREVENTION ASSEMBLIES

REDUCED PRESSURE PRINCIPLE
ASSEMBLY FOR DOMESTIC USE
EXTERNAL - HORIZONTAL

DRAWING NUMBER

10A-2