

NOTES:

1. REFERENCE TMWA STANDARD DETAIL 10L-2 FOR THRUST BLOCK SIZING AND REQUIREMENTS.
2. ALL BOLTS AND EXPOSED METAL SHALL BE COATED WITH BRUSHED-ON MASTIC.
3. TEE, VALVES, FITTINGS, DUCTILE IRON PIPE AND OTHER METAL PARTS SHALL BE ENCASED WITH POLYETHYLENE WRAP PER AWWA C105.
4. CONCRETE FOR PADS SHALL HAVE A COMPRESSIVE STRENGTH OF NOT LESS THAN 3,000 PSI AFTER 28 DAYS. BAG CONCRETE MIX IS NOT ACCEPTABLE.
5. POSITION OF FLG x PO VALVE (RUN) AND FLG x PO ADAPTER MAY SWITCH, REFERENCE WATER IMPROVEMENT PLANS.
6. AN ADDITIONAL FLG x PO VALVE MAY BE REQUIRED IN LIEU OF FLG x PO ADAPTER, REF. WATER IMPROVEMENT PLANS.

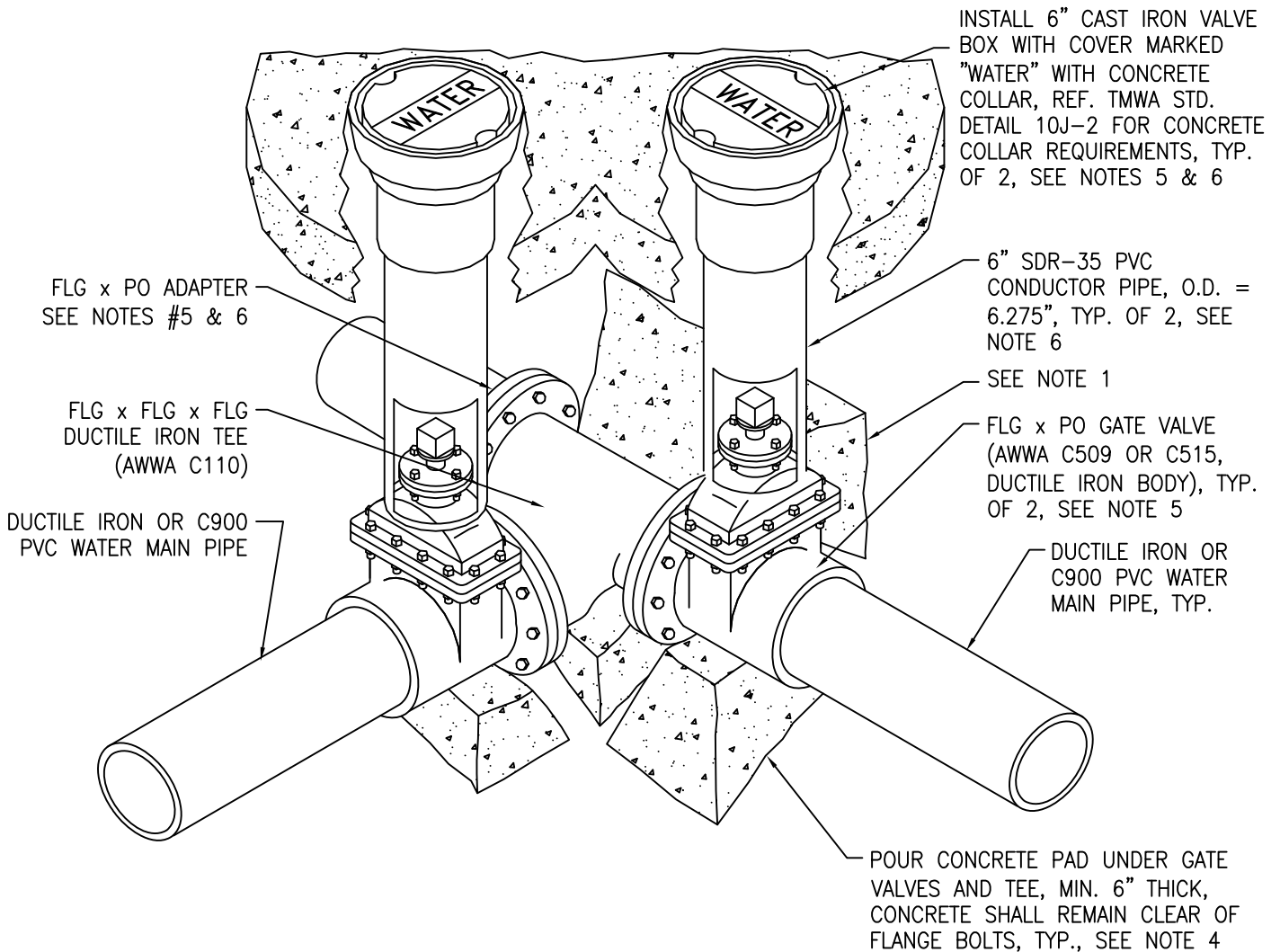

MATERIAL LIST

QTY.	DESCRIPTION
1	FLG x FLG x FLG DUCTILE IRON TEE (AWWA C110)
2	FLG x PO GATE VALVE WITH DUCTILE IRON BODY (AWWA C509 OR C515)
1	FLG x PO ADAPTER
2	6" CAST IRON VALVE BOX WITH COVER MARKED "WATER"
2	6" SDR-35 PVC CONDUCTOR PIPE SECTION, O.D. = 6.275"
-	CONCRETE BULK - THRUST BLOCKS, PADS, COLLARS



DATE

7/2011

REV

APPENDIX 10B
DISTRIBUTION BRANCH INSTALLATIONS

FLANGED TEES
FLG x PO GATE VALVES

DRAWING NUMBER

10B-3