

TEE / TAPPING SLEEVE PLAN VIEW

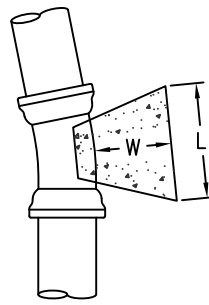

11.25° ELBOW PLAN VIEW

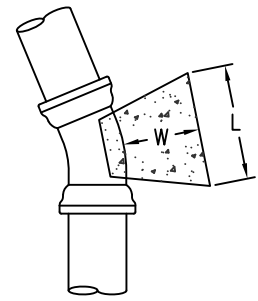

22.5° ELBOW PLAN VIEW

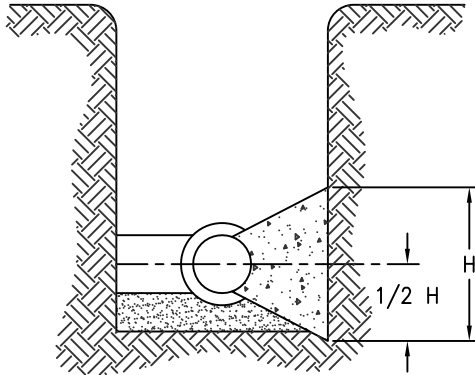

TYPICAL SECTION VIEW

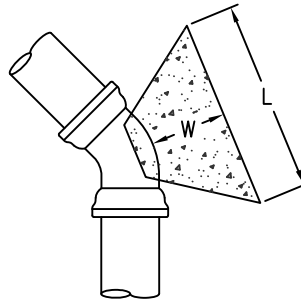

45° ELBOW PLAN VIEW

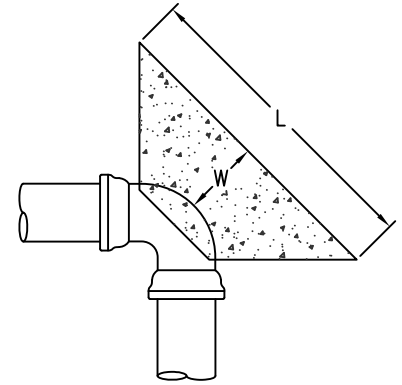

90° ELBOW PLAN VIEW

THRUST BLOCK DIMENSIONS

TEE, TAP, OR DEAD END					11.25° ELBOW			22.5° ELBOW			45° ELBOW			90° ELBOW		
BRANCH SIZE (INCHES)	L (FEET)	H (FEET)	W MIN. (FEET)	ELBOW SIZE (INCHES)	L (FEET)	H (FEET)	W MIN. (FEET)	L (FEET)	H (FEET)	W MIN. (FEET)	L (FEET)	H (FEET)	W MIN. (FEET)	L (FEET)	H (FEET)	W MIN. (FEET)
4	1.5	1	1	4	1	1	1	1	1	1	1.5	1	1	2	1	1
6	2	2	1	6	1	1	1	1.5	1	1	2	1.5	1	2.5	2	1
8	3	2	1	8	1.5	1	1	1.5	1.5	1	2.5	2	1	4	2	1
10	3.5	2.5	1	10	2	1	1	2	2	1	3	2.5	1	5	2.5	1
12	4.5	3	1	12	2	1.5	1	2.5	2	1	4	2.5	1	6	3	1

THRUST BLOCK DESIGN CRITERIA:

THRUST BLOCK SIZES HAVE BEEN CALCULATED USING THE METHOD AND EQUATIONS PUBLISHED IN *THRUST RESTRAINT DESIGN FOR DUCTILE IRON PIPE, SIXTH EDITION 2006* BY THE DUCTILE IRON PIPE RESEARCH ASSOCIATION (DIPRA) UTILIZING THE FOLLOWING DESIGN PARAMETERS: DESIGN PRESSURE = 150 PSI (SEE NOTE #4 BELOW), SOIL BEARING CAPACITY = 2,000 PSF (SEE NOTE #4 BELOW), SAFETY FACTOR = 1.5, AND NOMINAL PIPE DIAMETER

THRUST BLOCK NOTES:

1. CONCRETE FOR THRUST BLOCKS SHALL HAVE A MINIMUM 28-DAY COMPRESSIVE STRENGTH OF 3,000 PSI. REFERENCE SECTION 1.1.13 OF THE TRUCKEE MEADOWS WATER AUTHORITY ENGINEERING & CONSTRUCTION STANDARDS FOR ADDITIONAL REQUIREMENTS. BAG CONCRETE MIX IS NOT ACCEPTABLE.
2. ALL FITTINGS SHALL BE WRAPPED WITH POLYETHYLENE WRAP PER AWWA C105. MASTIC (BRUSH-ON) SHALL BE APPLIED TO ALL BOLTS, ETC.
3. THRUST BLOCKS SHALL BE POURED AGAINST UNDISTURBED SOIL. IN CASES WHERE THIS IS NOT PRACTICAL, BACKFILL AREA BEHIND WHERE THRUST BLOCK WILL BE POURED WITH TYPE 2, CLASS B AGGREGATE BASE (PER SECTION 200.01.03 OF THE STANDARD SPECIFICATIONS FOR PUBLIC WORKS CONSTRUCTION - ORANGE BOOK) COMPACTED TO 95% MAXIMUM DRY DENSITY AT OPTIMUM MOISTURE CONTENT AS DETERMINED BY PROCEDURES SET FORTH IN ASTM D 1557, CUT-BACK COMPACTED AGGREGATE BASE TO EXPOSE A FIRM SURFACE, THEN POUR THRUST BLOCK.
4. FOR SOIL BEARING CAPACITY LESS THAN 2,000 PSF AND/OR DESIGN PRESSURE IN EXCESS OF 150 PSI, INCREASE THRUST BLOCK BEARING AREAS ACCORDINGLY. REVISED THRUST BLOCK SCHEDULE FOR SPECIFIC CONDITIONS SHALL BE SUBMITTED BY THE DESIGN ENGINEER.



DATE

7/2011

REV

APPENDIX 10L
THRUST BLOCKS

TEES, TAPPING SLEEVES, DEAD ENDS
11.25, 22.5, 45 AND 90 DEGREE ELBOWS
4" TO 12"

DRAWING NUMBER

10L-2