

# CATALOG & BULLETIN INFORMATION

## PRESSURE TRANSMITTER

Service: Backwash Supply Pressure  
 Description: 3051T Inline Gage Pressure Transmitter and Integral Manifold Assembly, Range - 14.7 to 150 psi, output 4-20mA with HART Protocol, 1/2-14 FNPT process connection, 316L isolating diaphragm, silicone filled sensor, stainless steel housing, digital zero trim, LCD display with local interface. Two-valve integral manifold, 316 stainless steel body, PTFE packing.

Manufacturer: Hach  
 Manufacturer PN: Transmitter: 3051TG2A2B21JS5Q4DZM4, Manifold: 0306RT22AA11  
 WesTech PN: 23414A1004-280  
 Quantity: One (1)  
 Tag(s): AE/AIT-2463

REV	REVISION DESCRIPTION	ECN	DESIGNER	APPROVER	DATE
THIS DRAWING IS PROPERTY OF WESTECH ENGINEERING, INC. AND IS TRANSMITTED IN CONFIDENCE. NEITHER RECEIPT NOR POSSESSION CONFERS OR TRANSFERS ANY RIGHTS TO REPRODUCE, USE, OR DISCLOSE IN WHOLE OR IN PART, DATA CONTAINED HEREIN FOR ANY PURPOSE WITHOUT THE WRITTEN PERMISSION OF WESTECH ENGINEERING, INC.					
DESIGNER	RE60	<b>TITLE</b> CATALOG & BULLETIN INFORMATION PRESSURE TRANSMITTER MT ROSE WATER TREATMENT PLANT  <b>CLIENT</b> TRUCKEE MEADOWS WATER AUTHORITY ~ PO 03422 STANTEC CONSULTING, INC. ~ SPECIFICATION 13160			
CHECKER	DA48				
APPROVER	DA48				
DATE	2018-05-03				
FILE: 23414A-DS08-PRESSURE TRANSMITTER.docx		PROJECT 23414A	DOCUMENT NUMBER 23414A-DS08	SHEET 1 OF 2	REV -

# CATALOG & BULLETIN INFORMATION

This Page Intentionally Blank

REV	REVISION DESCRIPTION	ECN	DESIGNER	APPROVER	DATE
THIS DRAWING IS PROPERTY OF WESTECH ENGINEERING, INC. AND IS TRANSMITTED IN CONFIDENCE. NEITHER RECEIPT NOR POSSESSION CONFERS OR TRANSFERS ANY RIGHTS TO REPRODUCE, USE, OR DISCLOSE IN WHOLE OR IN PART, DATA CONTAINED HEREIN FOR ANY PURPOSE WITHOUT THE WRITTEN PERMISSION OF WESTECH ENGINEERING, INC.					
DESIGNER	RE60	<b>TITLE</b> CATALOG & BULLETIN INFORMATION PRESSURE TRANSMITTER MT ROSE WATER TREATMENT PLANT  <b>CLIENT</b> TRUCKEE MEADOWS WATER AUTHORITY ~ PO 03422 STANTEC CONSULTING, INC. ~ SPECIFICATION 13160			
CHECKER	DA48				
APPROVER	DA48				
DATE	2018-05-03				
FILE: 23414A-DS08-PRESSURE TRANSMITTER.docx		PROJECT	DOCUMENT NUMBER	SHEET	REV
		23414A	23414A-DS08	2 OF 2	-

# Rosemount 3051T In-Line Pressure Transmitter



Rosemount 3051T In-Line Pressure Transmitters are the industry standard for gage and absolute pressure measurement. The in-line, compact design allows the transmitter to be connected directly to a process for quick, easy and cost effective installation. Capabilities include:

- Power advisory can proactively detect degraded electrical loop integrity issues (option code DA0)
- LOI with straightforward menus and built-in configuration buttons (option code M4)
- Safety Certification (option code QT)

**Additional information:**

Specifications: [page 44](#)

Certifications: [page 56](#)

Dimensional drawings: [page 67](#)

See “Specifications” on [page 44](#) and options for more details on each configuration. Specification and selection of product materials, options, or components must be made by the purchaser of the equipment. See [page 53](#) for more information on material selection.

**Table 2. Rosemount 3051T In-Line Pressure Transmitter Ordering Information**

The starred offerings (★) represent the most common options and should be selected for best delivery. The non-starred offerings are subject to additional delivery lead time.

Model <sup>(1)</sup>	Transmitter type		
3051T	In-line pressure transmitter		
<b>Pressure type</b>			
G	Gage		★
A <sup>(2)</sup>	Absolute		★
<b>Pressure range</b>			
	<b>Gage (Rosemount 3051TG)<sup>(3)</sup></b>	<b>Absolute (Rosemount 3051TA)</b>	
1	-14.7 to 30 psi (-1,01 to 2,06 bar)	0 to 30 psia (0 to 2,06 bar)	★
2	-14.7 to 150 psi (-1,01 to 10,34 bar)	0 to 150 psia (0 to 10,34 bar)	★
3	-14.7 to 800 psi (-1,01 to 55,15 bar)	0 to 800 psia (0 to 55,15 bar)	★
4	-14.7 to 4000 psi (-1,01 to 275,79 bar)	0 to 4000 psia (0 to 275,79 bar)	★
5	-14.7 to 10000 psi (-1,01 to 689,47 bar)	0 to 10000 psia (0 to 689,47 bar)	★
6 <sup>(4)</sup>	-14.7 to 20000 psi (-1,01 to 1378,95 bar)	0 to 20000 psia (0 to 1378,95 bar)	
<b>Transmitter output</b>			
A <sup>(5)</sup>	4–20 mA with digital signal based on HART Protocol		★
F	FOUNDATION Fieldbus Protocol		★
W <sup>(6)</sup>	PROFIBUS PA Protocol		★
X <sup>(7)</sup>	Wireless (requires wireless options and engineered polymer housing)		★
M <sup>(8)</sup>	Low-power 1–5 Vdc with digital signal based on HART Protocol		

**Table 2. Rosemount 3051T In-Line Pressure Transmitter Ordering Information**

The starred offerings (★) represent the most common options and should be selected for best delivery. The non-starred offerings are subject to additional delivery lead time.

Process connection style		
2B	1/2–14 NPT female (range 1–5 only)	★
2C <sup>(9)</sup>	G1/2 A DIN 16288 male (range 1–4 only)	★
2F <sup>(10)</sup>	Coned and threaded, compatible with autoclave type F-250-C (range 5–6 only)	
61 <sup>(11)</sup>	Non-threaded Instrument flange (range 1–4 only)	
Isolating diaphragm <sup>(12)</sup>		Process connection wetted parts material
2	316L SST	316L SST ★
3	Alloy C-276	Alloy C-276 ★
7	Gold-plated 316 SST	316L SST
Sensor fill fluid		
1	Silicone	★
2 <sup>(11)</sup>	Inert	★
Housing material		Conduit entry size
A	Aluminum	1/2–14 NPT ★
B	Aluminum	M20 x 1.5 ★
E	Aluminum, ultra low copper	1/2–14 NPT
F	Aluminum, ultra low copper	M20 x 1.5
J	SST	1/2–14 NPT ★
K	SST	M20 x 1.5 ★
P <sup>(13)</sup>	Engineered polymer	No conduit entries ★
D <sup>(14)</sup>	Aluminum	G1/2
M <sup>(14)</sup>	SST	G1/2

**Wireless options (requires wireless output code X and engineered polymer housing code P)**

Wireless transmit rate, operating frequency, and protocol		
WA3	User configurable transmit rate, 2.4GHz WirelessHART Protocol	★
Antenna and SmartPower		
WP5	Internal antenna, compatible with Green Power Module (I.S. Power Module sold separately)	★

**Options (include with selected model number)**

Extended product warranty		
WR3	3-year limited warranty	★
WR5	5-year limited warranty	★

**Table 2. Rosemount 3051T In-Line Pressure Transmitter Ordering Information**

The starred offerings (★) represent the most common options and should be selected for best delivery. The non-starred offerings are subject to additional delivery lead time.

<b>Plantweb control functionality<sup>(15)</sup></b>		
A01	FOUNDATION Fieldbus control function block suite	★
<b>Plantweb diagnostic functionality</b>		
DA0 <sup>(24)</sup>	Power Advisory HART diagnostic	★
D01 <sup>(15)</sup>	FOUNDATION Fieldbus diagnostics suite	★
<b>Integral assembly<sup>(16)</sup></b>		
S5	Assemble to Rosemount 306 Integral Manifold	★
<b>Diaphragm seal assemblies<sup>(16)</sup></b>		
S1	Assemble to one Rosemount 1199 seal	★
<b>Mounting bracket<sup>(17)</sup></b>		
B4	Bracket for 2-in. pipe or panel mounting, all SST	★
<b>Product certifications</b>		
E8	ATEX Flameproof and Dust Certification	★
I1 <sup>(18)</sup>	ATEX Intrinsic Safety and Dust	★
IA	ATEX Intrinsic Safety for FISCO; for FOUNDATION Fieldbus or PROFIBUS PA Protocols only	★
N1	ATEX Type n Certification and Dust	★
K8	ATEX Flame-proof, Intrinsic Safety, Type n, Dust (combination of E8, I1, and N1)	★
E4 <sup>(19)</sup>	TIIS Flameproof	★
E5	FM Explosion-proof, Dust Ignition-proof	★
I5 <sup>(20)</sup>	FM Intrinsically Safe, Nonincendive	★
IE	FM FISCO Intrinsically Safe; for FOUNDATION Fieldbus or PROFIBUS PA Protocols only	★
K5	FM Explosion-proof, Dust Ignition-proof, Intrinsically Safe, and Division 2	★
C6	CSA Explosion-proof, Dust Ignition-proof, Intrinsically Safe, and Division 2	★
I6 <sup>(13)</sup>	CSA Intrinsic Safety	★
K6	CSA and ATEX Explosion-proof, Intrinsically Safe, and Division 2 (combination of C6, E8, and I1)	★
E7	IECEX Flameproof, Dust Ignition-proof	★
I7	IECEX Intrinsic Safety	★
N7	IECEX Type n Certification	★
K7	IECEX Flameproof, Dust Ignition-proof, Intrinsic Safety, and Type n (combination of I7, N7, and E7)	★
E2	INMETRO Flameproof	★
I2	INMETRO Intrinsic Safety	★
IB	INMETRO FISCO intrinsically safe; for FOUNDATION Fieldbus or PROFIBUS PA Protocols only	★
K2	INMETRO Flameproof, Intrinsic Safety	★
E3	China Flameproof	★

**Table 2. Rosemount 3051T In-Line Pressure Transmitter Ordering Information**

The starred offerings (★) represent the most common options and should be selected for best delivery. The non-starred offerings are subject to additional delivery lead time.

I3	China Intrinsic Safety	★
N3	China Type n	★
EM	Technical Regulations Customs Union (EAC) Flameproof	★
IM	Technical Regulations Customs Union (EAC) Intrinsic Safety	★
KM	Technical Regulations Customs Union (EAC) Flameproof and Intrinsic Safety	★
KB	FM and CSA Explosion-proof, Dust Ignition-proof, Intrinsically Safe, and Division 2 (combination of K5 and C6)	★
KD	FM, CSA, and ATEX Explosion-proof, Intrinsically Safe (combination of K5, C6, I1, and E8)	★
<b>Drinking water approval<sup>(21)</sup></b>		
DW	NSF drinking water approval	★
<b>Shipboard approvals<sup>(11)</sup></b>		
SBS	American Bureau of Shipping	★
SBV <sup>(22)</sup>	Bureau Veritas (BV)	★
SDN	Det Norske Veritas	★
SLL <sup>(22)</sup>	Lloyds Register (LR)	★
<b>Custody transfer</b>		
C5	Measurement Canada Accuracy Approval (Limited availability depending on transmitter type and range. Contact an Emerson representative.)	★
<b>Calibration certification</b>		
Q4	Calibration Certificate	★
QG <sup>(23)</sup>	Calibration Certificate and GOST Verification Certificate	★
QP	Calibration Certification and tamper evident seal	★
<b>Material traceability certification</b>		
Q8	Material Traceability Certification per EN 10204 3.1	★
<b>Quality certification for safety<sup>(24)</sup></b>		
QS	Prior-use certificate of FMEDA Data	★
QT	Safety certified to IEC 61508 with certificate of FMEDA	★
<b>Configuration buttons</b>		
D4 <sup>(24)</sup>	Analog zero and span	★
DZ <sup>(25)</sup>	Digital zero trim	★
<b>Display and interface options</b>		
M4 <sup>(26)</sup>	LCD display with LOI	★
M5	LCD display	★
<b>Wireless SST sensor module<sup>(13)</sup></b>		
WSM	Wireless SST sensor module	★

**Table 2. Rosemount 3051T In-Line Pressure Transmitter Ordering Information**

The starred offerings (★) represent the most common options and should be selected for best delivery. The non-starred offerings are subject to additional delivery lead time.

<b>Conduit plug<sup>(11)(27)</sup></b>		
DO	316 SST conduit plug	★
<b>Transient terminal block<sup>(11)(28)</sup></b>		
T1	Transient protection terminal block	★
<b>Software configuration<sup>(25)</sup></b>		
C1	Custom Software Configuration (For wired, see the Rosemount 3051 <a href="#">Configuration Data Sheet</a> . For wireless, see the Rosemount 3051 Wireless <a href="#">Configuration Data Sheet</a> .)	★
<b>Low power output</b>		
C2	0.8–3.2 Vdc output with digital signal based on HART Protocol (available with output code M only)	
<b>Alarm levels<sup>(24)</sup></b>		
C4	Analog output levels compliant with NAMUR recommendation NE 43, alarm high	★
CN	Analog output levels compliant with NAMUR recommendation NE 43, low alarm	★
CR	Custom alarm and saturation signal levels, high alarm (requires C1 and Rosemount 3051 <a href="#">Configuration Data Sheet</a> )	★
CS	Custom alarm and saturation signal levels, low alarm (requires C1 and Rosemount 3051 <a href="#">Configuration Data Sheet</a> )	★
CT	Rosemount standard low alarm	★
<b>Pressure testing</b>		
P1	Hydrostatic testing with certificate	
<b>Cleaning process area<sup>(29)</sup></b>		
P2	Cleaning for special service	
P3	Cleaning for <1 PPM chlorine/fluorine	
<b>Ground screw<sup>(11)(30)</sup></b>		
V5	External ground screw assembly	★
<b>Surface finish</b>		
Q16	Surface finish certification for sanitary remote seals	★
<b>Toolkit total system performance reports</b>		
QZ	Remote seal system performance calculation report	★
<b>Conduit electrical connector<sup>(11)</sup></b>		
GE	M12, 4-pin, male connector (eurofast)	★
GM	A size mini, 4-pin, male connector (minifast)	★
<b>NACE certificate<sup>(31)</sup></b>		
Q15	Certificate of Compliance to NACE MR0175/ISO15156 for wetted materials	★
Q25	Certificate of Compliance to NACE MR0103 for wetted materials	★

**Table 2. Rosemount 3051T In-Line Pressure Transmitter Ordering Information**

The starred offerings (★) represent the most common options and should be selected for best delivery. The non-starred offerings are subject to additional delivery lead time.

Cold temperature		
BR5	-50 °F (-58 °C) cold temperature	★
BR6	-76 °F (-60 °C) cold temperature	★
HART Revision configuration (requires HART output code A) <sup>(5)</sup>		
HR5	Configured for HART Revision 5	★
HR7	Configured for HART Revision 7	★
<b>Typical model number: 3051T G 5 F 2A 2 1 A B4</b>		

1. Select configuration buttons (option code D4 or DZ) or LOI (option code M4) if local configuration buttons are required.
2. Wireless output (code X) only available in absolute measurement type (code A) in range 1–5 with 1/2–14 NPT process connection (code 2B), and polymer housing (code P). Wireless output and range 6 is only available with coned and threaded process connection (code 2F) and polymer housing.
3. Rosemount 3051TG lower range limit varies with atmospheric pressure.
4. Not available with PROFIBUS PA or low power 1–5 Vdc transmitter output (option code W or M), inert sensor fill fluid (option code 2), NSW drinking water approval (option code DW), or assemble to manifolds (option code S5).
5. Option HR5 configures the HART output to HART Revision 5. Option HR7 configures the HART output to HART Revision 7. The device can be field configured to HART Revision 5 or 7 if desired. HART Revision 5 is the default HART output.
6. For local addressing and configuration, M4 LOI is required.
7. Requires wireless options and engineered polymer housing. Available approvals are FM Intrinsically Safe, (option code I5), CSA Intrinsically Safe (option code I6), ATEX Intrinsic Safety (option code I1), IECEx Intrinsic Safety (option code I7), and EAC Intrinsic Safety (option code IM).
8. Only available with C6, E2, E5, I5, K5, KB, and E8 product certifications. Not available with GE, GM, SBS, DA0, M4, D4, DZ, QT, HR5, HR7, CR, CS, and CT.
9. Wireless output (code X) only available in G<sup>1</sup>/2 A DIN 16288 male process connection (code 2C) with range 1–4, 316 SST isolating diaphragm (code 2), silicone fill fluid (code 1) and housing (code P).
10. Not available with wireless output for range 5.
11. Not available with wireless (output code X).
12. Materials of construction comply with recommendations per NACE MR0175/ISO 15156 for sour oil field production environments. Environmental limits apply to certain materials. Consult latest standard for details. Selected materials also conform to NACE MR0103 for sour refining environments.
13. Only available with wireless (output code X).
14. Not available with Product certifications options E8, K8, E5, K5, C6, K6, E7, K7, E2, K2, E3, KB, and KD.
15. Only valid with FOUNDATION Fieldbus output code F.
16. "Assemble-to" items are specified separately and require a completed model number.
17. Panel mounting bolts are not supplied.
18. Dust approval not applicable to output code X. See "Certificate: AG-0226; AG-0454; AG-0477" on page 62 for wireless approvals.
19. Only available with output codes A - 4–20mA HART, F - FOUNDATION Fieldbus, and W - PROFIBUS PA. Also only available with G<sup>1</sup>/2 housing thread types.
20. Nonincendive certification not provided with wireless output (code X).
21. Not available with Alloy C-276 isolator (option code 3), assemble-to manifolds (option code S5), assemble-to seals (option code S1), surface finish certification (option code Q16), and remote seal system report (option code QZ).
22. Only available with product certifications E7, E8, I1, I7, IA, K7, K8, KD, N1, and N7.
23. Contact an Emerson representative for availability.
24. Only available with HART 4–20 mA output (code A).
25. Only available with HART 4–20 mA output (code A) and wireless output (code X).
26. Not available with FOUNDATION Fieldbus (code F) and wireless output (code X) or low power (code M).
27. Transmitter is shipped with 316 SST conduit plug (uninstalled) in place of standard CS conduit plug.
28. The T1 option is not needed with FISCO Product Certifications; transient protection is included in the FISCO product certification codes IA, IB, and IE.
29. Not valid with alternate process connection S5.
30. The V5 option is not needed with T1 option; external ground screw assembly is included with the T1 option.
31. NACE compliant wetted materials are identified by Footnote 11.

## Functional specifications

### Range and sensor limits

Table 7. Rosemount 3051CD, 3051CG, 3051CF, and 3051L Range and Sensor Limits

Range <sup>(1)</sup>	Minimum span		Range and sensor limits			
	Rosemount 3051CD, 3051CG, 3051CF, 3051L <sup>(2)</sup>	Upper (URL)	Lower (LRL)			
			Rosemount 3051CD differential, 3051CF Flowmeters	Rosemount 3051CG gage <sup>(3)</sup>	Rosemount 3051L differential	Rosemount 3051L gage <sup>(3)</sup>
0	0.10 inH <sub>2</sub> O (0,24 mbar)	3.00 inH <sub>2</sub> O (7,45 mbar)	-3.00 inH <sub>2</sub> O (-7,45 mbar)	N/A	N/A	N/A
1	0.50 inH <sub>2</sub> O (1,24 mbar)	25.00 inH <sub>2</sub> O (62,16 mbar)	-25.00 inH <sub>2</sub> O (-62,16 mbar)	-25.00 inH <sub>2</sub> O (-62,16 mbar)	N/A	N/A
2	1.67 inH <sub>2</sub> O (4,15 mbar)	250.00 inH <sub>2</sub> O (621,60 mbar)	-250.00 inH <sub>2</sub> O (-621,60 mbar)	-250.00 inH <sub>2</sub> O (-621,60 mbar)	-250.00 inH <sub>2</sub> O (-621,60 mbar)	-250.00 inH <sub>2</sub> O (-621,60 mbar)
3	6.67 inH <sub>2</sub> O (16,58 mbar)	1000.00 inH <sub>2</sub> O (2,48 bar)	-1000.00 inH <sub>2</sub> O (-2,48 bar)	0.50 psia (34,47 mbar)	-1000.00 inH <sub>2</sub> O (-2,48 bar)	0.50 psia (34,47 mbar)
4	2.00 psi (137,89 mbar)	300.00 psi (20,68 bar)	-300.00 psi (-20,68 bar)	0.50 psia (34,47 mbar)	-300.00 psi (-20,68 bar)	0.50 psia (34,47 mbar)
5	13.33 psi (919,01 mbar)	2000.00 psi (137,89 bar)	-2000.00 psi (-137,89 bar)	0.50 psia (34,47 mbar)	N/A	N/A

1. Range 0 only available with Rosemount 3051CD. Range 1 only available with Rosemount 3051CD, 3051CG, or 3051CF. inH<sub>2</sub>O referenced at 68 °F.
2. For outputs options W and M, minimum span are: Range 1 - 0.50 inH<sub>2</sub>O (1,24 mbar), range 2 - 2.50 inH<sub>2</sub>O (6,21 mbar), range 3 - 10.00 inH<sub>2</sub>O (24,86 mbar), range 4 - 3.00 psi (0,21 bar), range 5 - 20.00 psi (1,38 bar).
3. Assumes atmospheric pressure of 14.7 psig.

Table 8. Rosemount 3051CA and 3051T Range and Sensor Limits

Range	Rosemount 3051CA			Range	Rosemount 3051T				
	Minimum span <sup>(1)</sup>		Range and sensor limits		Minimum span <sup>(1)</sup>		Range and sensor limits		Lower <sup>(2)</sup> (LRL) (gage)
	Upper (URL)				Upper (URL)		Lower (LRL) (absolute)		
1	0.30 psi (20,68 mbar)	30 psia (2,06 bar)	0 psia (0 bar)	1	0.30 psi (20,68 mbar)	30.00 psi (2,06 bar)	0 psia (0 bar)	-14.70 psig (-1,01 bar)	
2	1.00 psi (68,94 mbar)	150 psia (10,34 bar)	0 psia (0 bar)	2	1.00 psi (68,94 mbar)	150.00 psi (10,34 bar)	0 psia (0 bar)	-14.70 psig (-1,01 bar)	
3	5.33 psi (367,49 mbar)	800 psia (55,15 bar)	0 psia (0 bar)	3	5.33 psi (367,49 mbar)	800.00 psi (55,15 bar)	0 psia (0 bar)	-14.70 psig (-1,01 bar)	
4	26.67 psi (1,83 bar)	4000 psia (275,79 bar)	0 psia (0 bar)	4	26.67 psi (1,83 bar)	4000.00 psi (275,79 bar)	0 psia (0 bar)	-14.70 psig (-1,01 bar)	
5	N/A	N/A	N/A	5	2000.00 psi (137,89 bar)	10000.00 psi (689,47 bar)	0 psia (0 bar)	-14.70 psig (-1,01 bar)	
6	N/A	N/A	N/A	6	4000.00 psi (275,79 bar)	20000.00 psi (1378,95 bar)	0 psia (0 bar)	-14.70 psig (-1,01 bar)	

1. For output options W and M, minimum span are: range 2 - 1.50 psi (0,10 bar), range 3 - 8.00 psi (0,55 bar), range 4 - 40.00 psi (2,75 bar), range 5 for Rosemount 3051T - 2000.00 psi (137,89 bar).
2. Assumes atmospheric pressure of 14.7 psig.

**Power consumption**

3.0 mA, 18–36 mW

**Minimum load impedance**

100 kΩ (V<sub>out</sub> wiring)

**Indication**

Optional 5-digit LCD display

**Overpressure limits**

**Rosemount 3051CD/CG/CF**

- Range 0: 750 psi (51,71 bar)
- Range 1: 2000 psig (137,90 bar)
- Ranges 2–5: 3626 psig (250,00 bar)  
4500 psig (310,26 bar) for option code P9

**Rosemount 3051CA**

- Range 1: 750 psia (51,71 bar)
- Range 2: 1500 psia (103,42 bar)
- Range 3: 1600 psia (110,32 bar)
- Range 4: 6000 psia (413,69 bar)

**Rosemount 3051TG/TA**

- Range 1: 750 psi (51,71 bar)
- **Range 2: 1500 psi (103,42 bar)**
- Range 3: 1600 psi (110,32 bar)
- Range 4: 6000 psi (413,69 bar)
- Range 5: 15000 psi (1034,21 bar)
- Range 6: 24000 psi (1654,74 bar)

For Rosemount 3051L or level flange option codes FA, FB, FC, FD, FP, and FQ, limit is 0 psia to the flange rating or sensor rating, whichever is lower.

**Table 9. Rosemount 3051L and Level Flange Rating Limits**

Standard	Type	CS rating	SST rating
ANSI/ASME	Class 150	285 psig	275 psig
ANSI/ASME	Class 300	740 psig	720 psig
ANSI/ASME	Class 600	1480 psig	1440 psig
At 100 °F (38 °C), the rating decreases with increasing temperature, per ANSI/ASME B16.5.			
DIN	PN 10–40	40 bar	40 bar
DIN	PN 10/16	16 bar	16 bar
DIN	PN 25/40	40 bar	40 bar
At 248 °F (120 °C), the rating decreases with increasing temperature, per DIN 2401.			

**Static pressure limit**

**Rosemount 3051CD only**

Operates within specifications between static line pressures of 0.5 psia and 3626 psig (4500 psig [310, 26 bar] for option code P9).

Range 0: 0.5 psia and 750 psig (0,03 bar and 51,71 bar)

Range 1: 0.5 psia and 2000 psig (0,03 bar and 137, 90 bar)

**Burst pressure limits**

**Rosemount 3051C, 3051CF Coplanar or Traditional process flange**

10081 psig (695,06 bar)

**Rosemount 3051T In-Line**

- Ranges 1–4: 11016 psi (759,53 bar)
- Range 5: 26016 psig (1793,74 bar)
- Range 6: 46092 psi (3177,93 bar)

**Failure mode alarm**

**HART 4–20 mA (output option code A)**

If self-diagnostics detect a sensor or microprocessor failure, the analog signal is driven either high or low to alert the user. High or low failure mode is user-selectable with a jumper/switch on the transmitter. The values to which the transmitter drives its output in failure mode depend on whether it is configured to standard, NAMUR-compliant, or custom levels (see alarm configuration below). The values for each are as follows:

	High alarm	Low alarm
Default	≥ 21.75 mA	≤ 3.75 mA
NAMUR compliant <sup>(1)</sup>	≥ 22.5 mA	≤ 3.6 mA
Custom levels <sup>(2)</sup>	20.2 – 23.0 mA	3.4 – 3.8 mA

1. Analog output levels are compliant with NAMUR recommendation NE 43, see option codes C4 or C5.
2. Low alarm must be 0.1 mA less than low saturation and high alarm must be 0.1 mA greater than high saturation.

**Output code M**

If self-diagnostics detect a gross transmitter failure, the analog signal will be driven either below 0.94 V or above 5.4 V to alert the user (below 0.75 V or above 4.4 V for Option C2). High or low alarm signal is user-selectable by internal jumper.

**Output code F, W, and X**

If self-diagnostics detect a gross transmitter failure, that information gets passed as an alert and a status along with the process variable.

**Temperature limits**

**Ambient<sup>(1)</sup>**

- –40 to 185 °F (–40 to 85 °C)
- With LCD display<sup>(2)(3)</sup>: –40 to 176 °F (–40 to 80 °C)

1. For BR5 option code ambient temperature limits are –58 to 185 °F (–50 to 85 °C) and for BR6 option code ambient temperature limits are –76 to 185 °F (–60 to 85 °C).
2. For the output code M and W, LCD display may not be readable and LCD display updates will be slower at temperatures below –22 °F (–30 °C).
3. Wireless LCD display may not be readable and LCD display updates will be slower at temperature below –4 °F (–20 °C).

**Storage<sup>(1)</sup>**

- -76 to 230 °F (-60 to 110 °C)
- With LCD display: -76 to 185 °F (-60 to 85 °C)
- With wireless output: -40 to 185 °F (-40 to 85 °C)

1. If storage temperature is above 85 °C, perform a sensor trim prior to installation.

**Process**

At atmospheric pressures and above. See Table 10.

**Table 10. Rosemount 3051 Process Temperature Limits**

<b>Rosemount 3051CD, 3051CG, 3051CF, 3051CA</b>	
Silicone fill sensor <sup>(1)</sup>	
with Coplanar flange	-40 to 250 °F (-40 to 121 °C) <sup>(2)</sup>
with Traditional flange	-40 to 300 °F (-40 to 149 °C) <sup>(2)(3)</sup>
with Level flange	-40 to 300 °F (-40 to 149 °C) <sup>(2)</sup>
with 305 Integral Manifold	-40 to 300 °F (-40 to 149 °C) <sup>(2)</sup>
Inert fill sensor <sup>(1)(4)</sup>	-40 to 185 °F (-40 to 85 °C) <sup>(5)(6)</sup>
<b>Rosemount 3051T (process fill fluid)</b>	
Silicone fill sensor <sup>(1)</sup>	-40 to 250 °F (-40 to 121 °C) <sup>(2)</sup>
Inert fill sensor <sup>(1)</sup>	-22 to 250 °F (-30 to 121 °C) <sup>(2)</sup>
<b>Rosemount 3051L low-side temperature limits</b>	
Silicone fill sensor <sup>(1)</sup>	-40 to 250 °F (-40 to 121 °C) <sup>(2)</sup>
Inert fill sensor <sup>(1)</sup>	-40 to 185 °F (-40 to 85 °C) <sup>(5)</sup>
<b>Rosemount 3051L high-side temperature limits (process fill fluid)</b>	
SYL THERM XLT	-102 to 293 °F (-75 to 145 °C)
D.C. Silicone 704	32 to 401 °F (0 to 205 °C)
D.C. Silicone 200	-49 to 401 °F (-45 to 205 °C)
Inert	-49 to 320 °F (-45 to 160 °C)
Glycerin and water	5 to 203 °F (-15 to 95 °C)
Neobee M-20	5 to 401 °F (-15 to 205 °C)
Propylene glycol and Water	5 to 203 °F (-15 to 95 °C)

1. Process temperatures above 185 °F (85 °C) require derating the ambient limits by a 1.5:1 ratio.
2. 220 °F (104 °C) limit in vacuum service; 130 °F (54 °C) for pressures below 0.5 psia.
3. Rosemount 3051CD0 process temperature limits are -40 to 212 °F (-40 to 100 °C).
4. Inert fill with traditional flange on Range 0: limits are 32 to 185 °F (0 to 85 °C).
5. 160 °F (71 °C) limit in vacuum service.
6. Not available for Rosemount 3051CA.

**Humidity limits**

0–100% relative humidity

**Turn-on time**

Performance within specifications less than 2.0 seconds (20.0 seconds for PROFIBUS PA and FOUNDATION Fieldbus Protocols) after power is applied to the transmitter.<sup>(1)</sup>

1. Does not apply to wireless option code X.

**Volumetric displacement**

Less than 0.005-in<sup>3</sup> (0,08 cm<sup>3</sup>)

**Damping**

**4–20 mA HART Protocol**

Analog output response to a step input change is user-enterable from 0.0 to 60 seconds for one time constant. This software damping is in addition to sensor module response time.

**FOUNDATION Fieldbus Protocol**

- Transducer block: User configurable
- AI Block: User configurable

**PROFIBUS PA Protocol**

AI block only: User configurable

**Physical specifications**

**Material selection**

Emerson provides a variety of Rosemount products with various product options and configurations including materials of construction that can be expected to perform well in a wide range of applications. The Rosemount product information presented is intended as a guide for the purchaser to make an appropriate selection for the application. It is the purchaser's sole responsibility to make a careful analysis of all process parameters (such as all chemical components, temperature, pressure, flow rate, abrasives, contaminants, etc.), when specifying product materials, options, and components for the particular application. Emerson is not in a position to evaluate or guarantee the compatibility of the process fluid or other process parameters with the product options, configuration, or materials of construction selected.

**Electrical connections**

1/2–14 NPT, G1/2, and M20 x 1.5 conduit. The polymer housing code P) has no conduit entries. HART interface connections fixed to terminal block for output code A and to 701P Power Module for output code X.

**Process connections**

**Rosemount 3051C**

- 1/4–18 NPT on 2 1/8-in. centers
- 1/2–14 NPT on 2-, 2 1/8-, or 2 1/4-in. centers

**Figure 9. Rosemount 3051T**

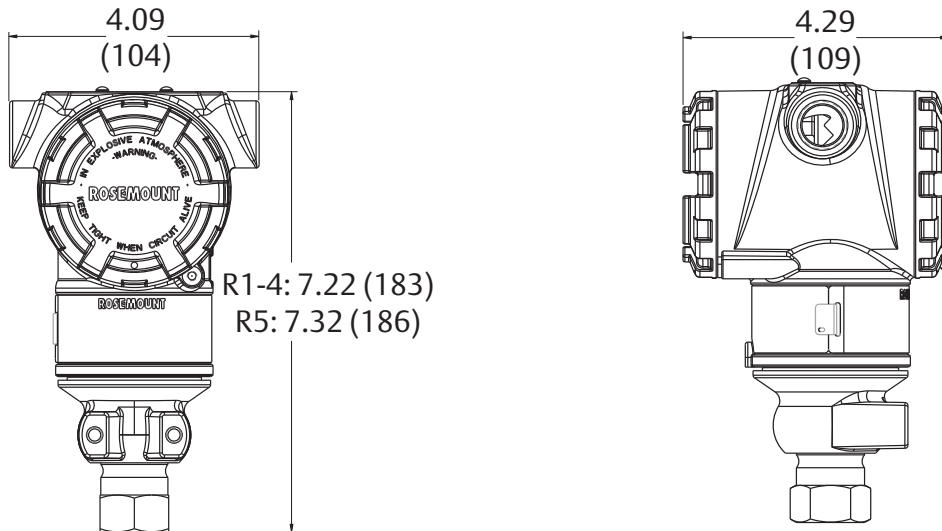

Dimensions are in inches (millimeters).

**Figure 10. Rosemount 3051T Wireless Housing**

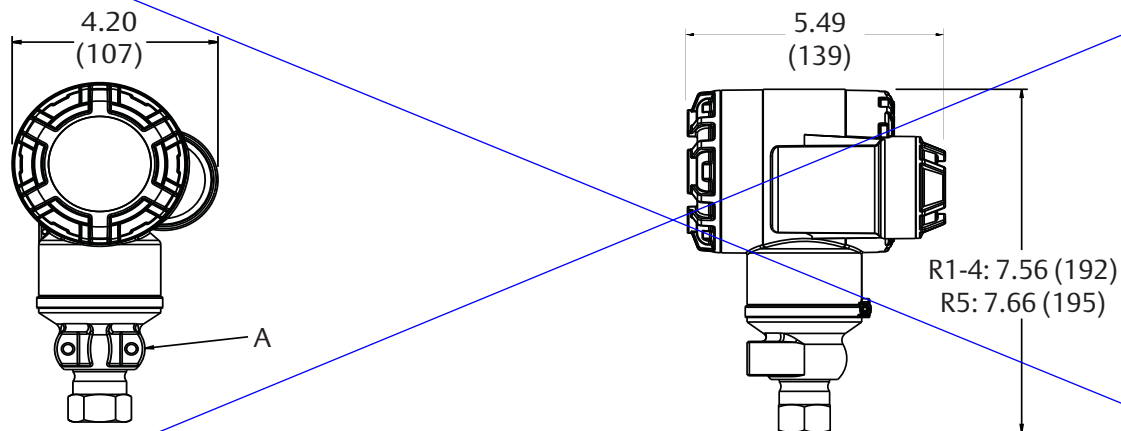

A. U-Bolt bracket

Dimensions are in inches (millimeters).

Figure 11. Rosemount 3051T In-Line Range 6

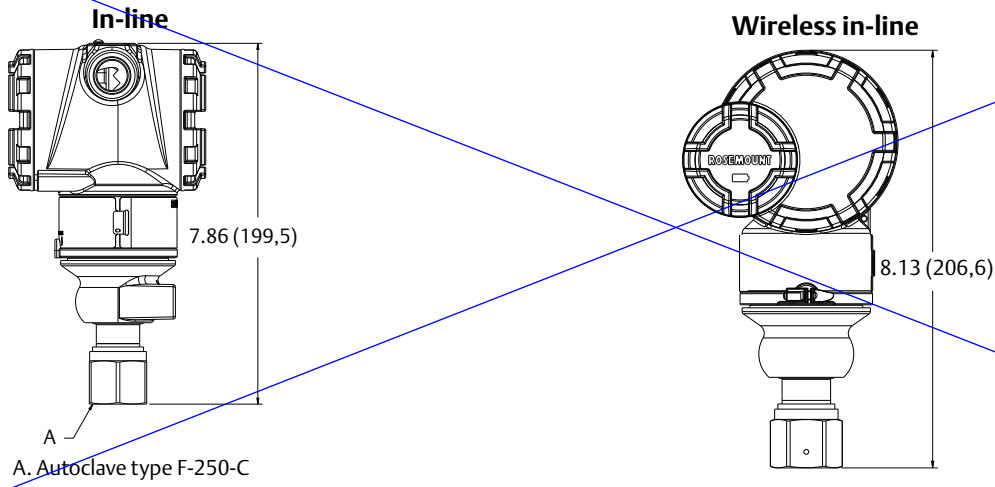
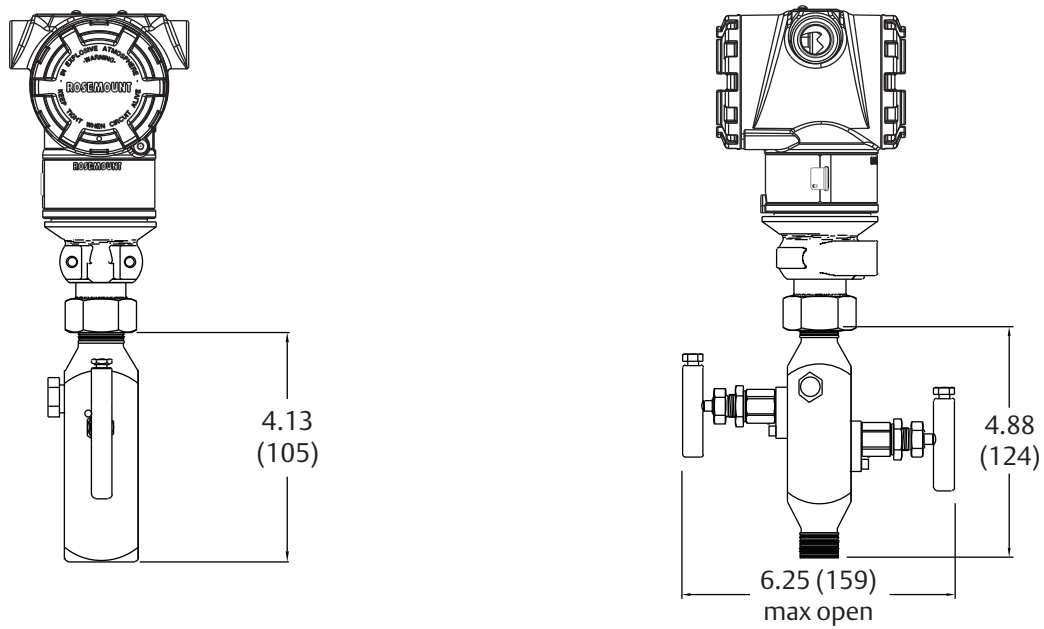

Figure 12. Rosemount 3051T with Rosemount 306 2-Valve Integral Manifold



Dimensions are in inches (millimeters).

**STANTEC  
THIS PAGE ONLY  
NO EXCEPTION TAKEN**

This Page Intentionally Blank

# Rosemount™ Manifolds



- Factory assembled, leak-tested, and calibrated
- Full breadth of offering including integral, in-line, and conventional
- Integral design enables “flangeless” connection to instrument
- Block and bleed, 2-, 3-, and 5-valve configurations
- Compact, lightweight design
- Easy in-process calibration
- Direct-mount capability
- Available in NACE®-compliant materials of construction

# Valve configuration

## Block-and-bleed

The block-and-bleed configuration is available on the Rosemount 306 Manifold for use with in-line gage and absolute pressure transmitters. A single isolate valve provides instrument isolation and a bleed screw provides drain/vent capabilities.

### Rosemount 306 Manifold

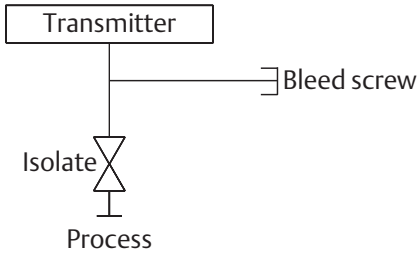

## Two-valve

The 2-valve configuration is available on Rosemount 305, 306, and 304 Manifolds for use with absolute and gage pressure transmitters. An isolate valve provides instrument isolation and a drain/vent valve allows venting, draining, or calibration.

### Rosemount 305 and 306 Manifolds

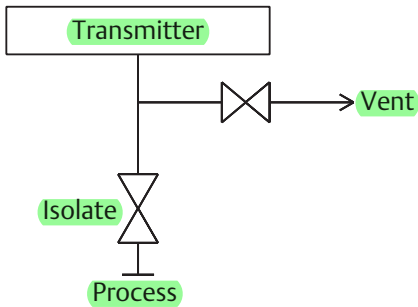

### Rosemount 304 Manifold

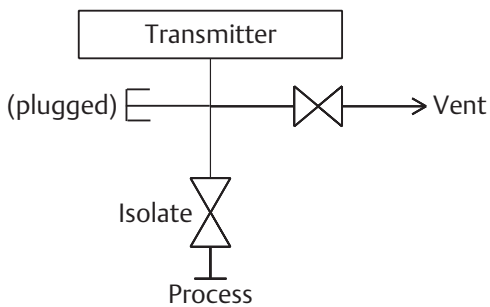

## Three-valve

The 3-valve configuration is available on Rosemount 305 and 304 Manifolds for use with differential pressure and multi-variable transmitters. Two isolate valves provide instrument isolation, and one equalize valve is positioned between the high and low process connections.

### Rosemount 305 Manifold

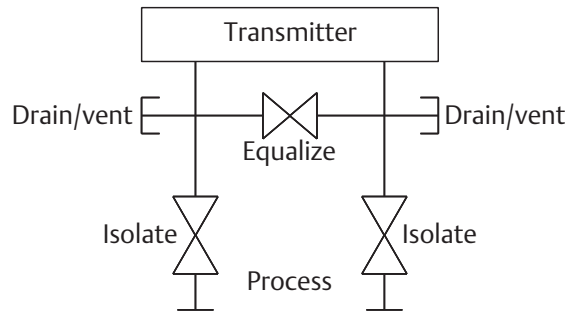

### Rosemount 304 (Traditional) Manifold

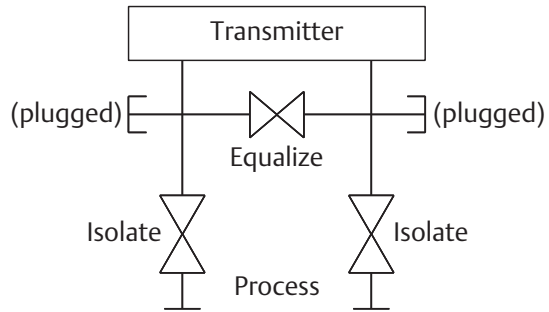

### Rosemount 304 (Wafer) Manifold

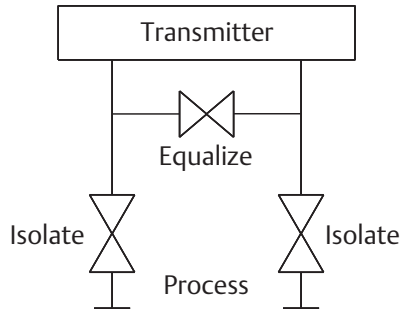

#### Note

Vent ports receive plastic caps to protect threaded connections unless otherwise noted.

#### Note

Plugged connections receive 1/4-in. NPT plugs unless otherwise noted.

## Rosemount Manifolds

Specification and selection of product materials, options, or components must be made by the purchaser of the equipment. See page 13 for more information on material selection.

**Table 3. Rosemount 306 Pressure Manifold Ordering Information**

The starred offerings (★) represent the most common options and should be selected for best delivery. The non-starred offerings are subject to additional delivery lead time.

Model	Product description			
0306	Pressure manifold			
<b>Manufacturer</b>				
R	Rosemount			★
<b>Manifold style</b>				
T	Threaded			★
<b>Manifold type</b>				
1	Block-and-bleed			★
2	2-valve			★
3 <sup>(1)</sup>	2-valve (per ASME B31.1 power piping code)			
<b>Body<sup>(2)</sup></b>		<b>Bonnet</b>	<b>Stem and tip/ball</b>	
2	316 SST/316L SST	316 SST	316 SST	★
3 <sup>(3)(4)</sup>	Alloy C-276	Alloy C-276	Alloy C-276	
<b>Process connection</b>				
AA	1/2–14 male NPT process connection for in-line transmitter			★
AW	1/2–14 male NPT process connection for Rosemount Wireless Pressure Gauge			★
BA <sup>(3)</sup>	1/2–14 female NPT process connection for in-line transmitter			★
BW	1/2–14 female NPT process connection for Rosemount Wireless Pressure Gauge			★
<b>Packing material</b>				
1 <sup>(5)</sup>	PTFE			★
2 <sup>(6)</sup>	Graphite-based			
<b>Valve seat</b>				
1	Integral			★

### Options

<b>Extended product warranty</b>				
WR3	3-year limited warranty		★	
WR5	5-year limited warranty		★	
<b>Cleaning<sup>(7)</sup></b>				
P2	Cleaning for special services			

**Table 3. Rosemount 306 Pressure Manifold Ordering Information**

The starred offerings (★) represent the most common options and should be selected for best delivery. The non-starred offerings are subject to additional delivery lead time.

<b>Material recommendations for NACE<sup>(4)(8)</sup></b>		
SG	Sour gas (meets NACE MR0175/ISO 15156, MR0103/ISO 17495)	★
<b>Typical integral manifold model number: 306 R T 2 2 BA 1 1</b>		

1. Only available with 316 SST materials of construction and graphite-based packing.
2. Refer to Table 14 on page 18 for additional detail on process wetted materials of construction.
3. Not available with block-and-bleed manifold type.
4. Materials of Construction comply with recommendations per NACE MR0175/ISO 15156 for sour oil field production environments. Environmental limits apply to certain materials. Consult latest standard for details. Selected materials also conform to NACE MR0103/ISO 17495 for sour refining environments.
5. Includes PTFE tape on drain/vent valves and plugs.
6. Includes graphite tape on plugs.
7. Not available with graphite-based packing material code 2.
8. Only allowed with material of construction code 2.

**Figure 2. Rosemount 306 In-line Manifolds**

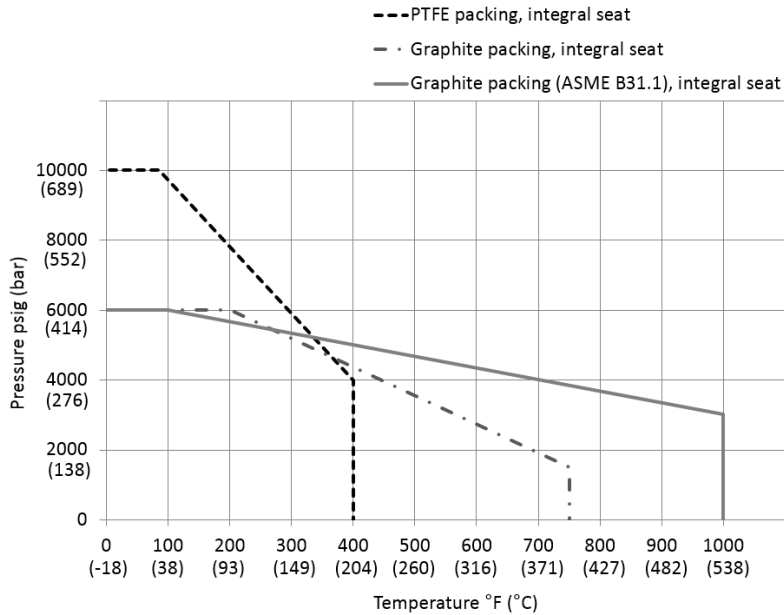

**Table 6. Rosemount 306 In-line Manifolds**

Packing	Seat	Pressure and temperature ratings
PTFE	Integral	10000 psi @ 85 °F (689 bar @ 29 °C) 4000 psi @ 400 °F (276 bar @ 204 °C)
Graphite	Integral	6000 psi @ 200 °F (414 bar @ 93 °C) 1500 psi @ 750 °F (103 bar @ 399 °C)
Graphite (ASME B31.1)	Integral	6000 psi @ 100 °F (414 bar @ 38 °C) 3030 psi @ 1000 °F (201 bar @ 538 °C)

## Instrument connections

**Table 8. Manifold - Transmitter Interface**

Model	Connection
Rosemount 305 Integral Manifold	Mounted directly to coplanar sensor module of transmitter, 1.3-in. (287 mm) center-to-center process isolators
Rosemount 306 In-line Manifold	1/2-14 male NPT for In-line transmitters 1/2-14 female NPT for Rosemount Wireless Pressure Gauge
Rosemount 304 Conventional Manifold	Mounted to traditional transmitter flange, 2 1/8-in. (54 mm) center-to-center connection per IEC 61518, Type B shut-off device (without spigot)

## O-rings

**Figure 4. Rosemount 305 Integral Manifold**

Sensor module-to-manifold O-rings  
 Specified in the transmitter model number.

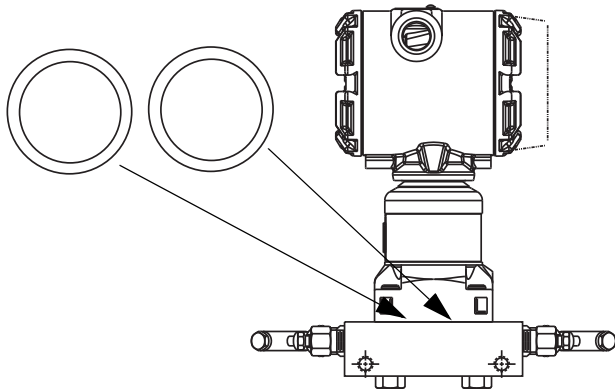

**Figure 5. Rosemount 304 Conventional Manifold**

Manifold-to-flange O-rings  
 Same material as specified by manifold "Packing Material" selection.<sup>(1)</sup>

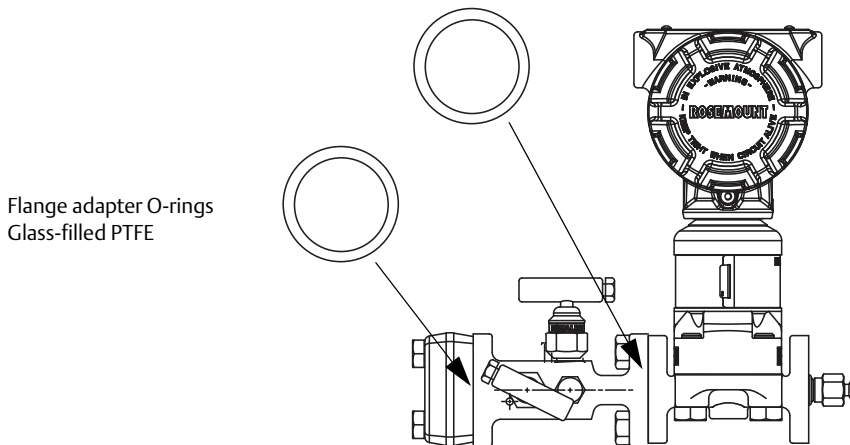

1. Available in packing material code 1 (PTFE) or code 2 (Graphite).

## Process connections

**Table 9. Rosemount 305 Integral Manifold**

Style	Connection
Coplanar	1/2–14 female NPT
Traditional	1/4–18 female NPT (process adapters optional)

**Table 10. Rosemount 306 In-line Manifold**

Style	Connection
Block-and-bleed	1/2–14 male NPT <sup>(1)</sup>
2-valve	1/2–14 NPT (male or female)

1. 1/2-14 female NPT option only available with Wireless Pressure Gauge.

**Table 11. Rosemount 304 Conventional Manifold**

Style	Connection
Flange by pipe	1/2–14 female NPT
Flange by flange	2 1/8-in. (54 mm) center-to-center connection (process adapters required)
Wafer	1/2-14 female NPT



## Vent port connections

1/4–18 female NPT

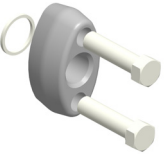
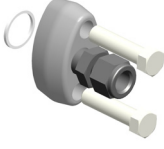
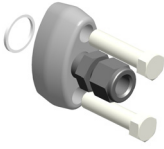
**Table 12. Adapters and Connectors**

Option	Description	Image
DF	1/2-14 NPT female flange adapter • Available with Rosemount 305 Integral and 304 Conventional Manifolds	
DT	1/2-in. ferrule tube flange adapter • Available with Rosemount 304 Conventional Manifold	
DQ	12mm ferrule tube flange adapter • Available with Rosemount 305 Integral and 304 Conventional Manifolds	

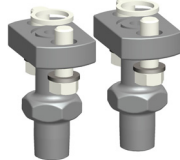
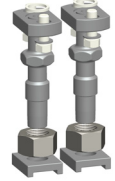
**Table 12. Adapters and Connectors**

Option	Description	Image
DV <sup>(1)</sup>	Non-stabilized connector • 3.00-in. • No stabilizing foot • Includes assembly hardware	
DH <sup>(1)</sup>	Stabilized extended connectors • 4.75-in. • Stabilizing foot • Includes assembly hardware	
G2 <sup>(1)(2)</sup>	Dielectric isolators • Rated to 2500 VDC and 5 mega-Ohms • Includes bolts sleeves and assembly hardware	

1. Only allowed with both Rosemount 304 Manifold type code 6 and process connection code F. Not allowed with Graphite-based packing code 2.
2. Maximum working pressure of assembly limited to 4500 psi (310 bar), 3626 psi (250 bar) at –20 °F (–29 °C), and 3626 psi (250 bar) at 150 °F (66 °C).

## Manifold bolts

Standard material is plated Carbon Steel per ASTM A449, Type 1

Alternative bolt materials offered through option codes:

- L4 for Austenitic 316 stainless steel bolts
- L5 for ASTM A193, Grade B7M Bolts
- L8 for ASTM A193, Grade B8M Class 2 bolts

## Materials of construction

### Process wetted

Table 13. Rosemount 305 Integral Manifold

Component	Option 2	Option 2 with SG	Option 3	Option 4
Body	316 SST/ 316L SST	316 SST/ 316L SST	Alloy C-276	Alloy 400
Ball/tip	316 SST/ 316Ti SST	Alloy C-276	Alloy C-276	Alloy 400
Stem	316 SST	Alloy C-276	Alloy C-276	Alloy 400
Packing	PTFE/ Graphite	PTFE/ Graphite	PTFE/ Graphite	PTFE/ Graphite
Bonnet	316 SST	316 SST	Alloy C-276	Alloy 400
Pipe plug	316 SST	316 SST	Alloy C-276	Alloy 400
Drain/vent valve	316 SST	Alloy C-276	Alloy C-276	Alloy 400

### Typical

Figure 6. Typical Rosemount Manifold Valve

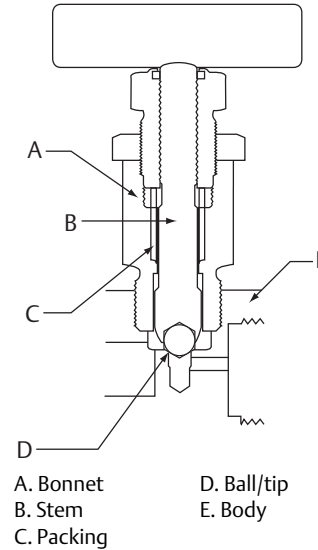

Table 14. Rosemount 306 In-line Manifold

Component	Option 2	Option 2 with SG	Option 3
Body	316 SST/ 316L SST	316 SST/ 316L SST	Alloy C-276
Ball/tip	316 SST/ 316Ti SST	Alloy C-276	Alloy C-276
Stem	316 SST	Alloy C-276	Alloy C-276
Packing	PTFE/Graphite	PTFE/Graphite	PTFE/Graphite
Bonnet	316 SST	316 SST	Alloy C-276
Pipe plug	316 SST	316 SST	Alloy C-276
Bleed screw	316 SST/ 316Ti SST	Alloy C-276	Alloy C-276

## Estimated weight

Table 16. Rosemount 305 Integral Manifold

Description	Weight
2-valve coplanar	4.5 lbs (2.0 kg)
2-valve traditional	6.0 lbs (2.7 kg)
3-valve coplanar	4.7 lbs (2.1 kg)
3-valve traditional	6.0 lbs (2.7 kg)
5-valve coplanar	6.5 lbs (3.0 kg)

Table 15. Rosemount 304 Conventional Manifold

Component	Option 2	Option 2 with SG	Option 5
Body	316 SST/ 316L SST	316 SST/ 316L SST	CS
Ball/tip	316 SST/ 316Ti SST	Alloy C-276	316 SST
Stem	316 SST	Alloy C-276	316 SST
Packing	PTFE/ Graphite	PTFE/ Graphite	PTFE
Bonnet	316 SST	316 SST	CS
Pipe plug	316 SST	316 SST	CS

Table 17. Rosemount 306 In-line Manifold

Description	Weight
Block-and-bleed	1.1 lbs (0.5 kg)
2-valve	2.5 lbs (1.1 kg)

Table 18. Rosemount 304 Conventional Manifold

Description	Weight
2-valve traditional flange × NPT	5.0 lbs (2.3 kg)
2-valve traditional flange × flange	5.5 lbs (2.5 kg)
3-valve traditional flange × NPT	5.2 lbs (2.4 kg)
3-valve traditional flange × flange	5.7 lbs (2.6 kg)
3-valve wafer flange × NPT	4.0 lbs (1.8 kg)
5-valve wafer flange × NPT	5.7 lbs (2.6 kg)
5-valve traditional flange × NPT	5.7 lbs (2.6 kg)
5-valve traditional flange × flange	5.7 lbs (2.6 kg)

## Rosemount 306 Manifold<sup>(1)</sup>

**Figure 15. Rosemount 306RT Pressure Style Manifold (3051S\_T Shown)<sup>(2)</sup>**

**Block-and-bleed style**

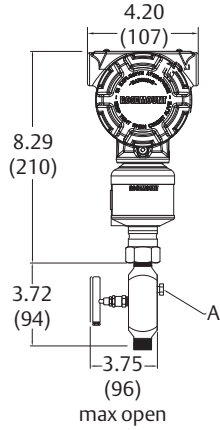

**2-valve style**

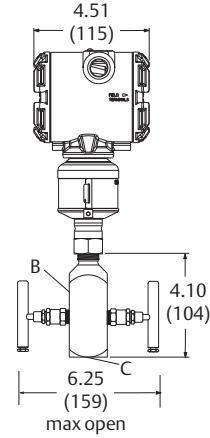

- A. Bleed screw (unspecified dimension) - not designed for accessory attachments.  
 B. 1/4-in. vent connection—pipe plug supplied with manifold, but not installed at factory (pipe plug supplied loose)  
 C. 1/2–14 NPT female NPT process connection (code BA)  
 Dimensions are in inches (millimeters).

## Rosemount 304 Manifold<sup>(1)</sup>

**Figure 16. Rosemount 304RT 2-Valve Flange × NPT Conventional Manifold**  
**Instrument side**

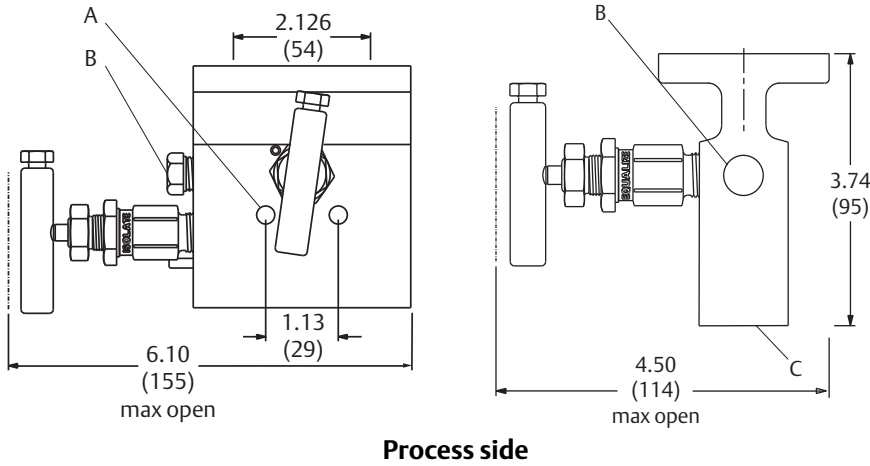

- A.  $\varnothing$  0.281 mounting holes (2)  
 B. 1/4-in. NPT test (plugged)  
 C. 1/2-in. NPT process connection on 2.125 (54) centers (2)  
 Dimensions are in inches (millimeters).

1. Manifold handle assembly may vary slightly from image shown. All valve handle assemblies provide the same function and meet all stated drawing dimensions.  
 2. Manifold valve orientation may vary with respect to transmitter mounting holes.

**STANTEC  
THIS PAGE ONLY  
NO EXCEPTION TAKEN**

This Page Intentionally Blank

## CATALOG & BULLETIN INFORMATION

### PRESSURE SWITCHES AND ACCESSORIES

- Description:** Filter Pressure Switch Assembly consisting of one Low Pressure Switch, one High Pressure Switch, and one Compound Pressure.
- Function:** Monitor pressure in filter below the media and indicate low pressure (terminal headloss) or high backwash supply pressure (shutdown backwash).
- Location:** Tap into Filter Effluent nozzle side
- WesTech PN:** 1-9209
- Quantity:** Two (2) Assemblies consisting of:
- Description:** Vacuum Switch, P-Series, single stage fixed dead band, operating range 30 Hg -14 psig, snap action SPDT switch (15 A, 125 VAC), watertight enclosure, transducer with 0.25 inch NPT connection, brass with BUNA-N seals.
- Manufacturer:** ASCO
- Mfg. PN:** PB21B/RV24A21
- WesTech PN:** 2-13600/2-16951
- Quantity:** One (1) per assembly
- Tag(s):** PS-101, PS-201
- Description:** Pressure Switch, P-Series, single stage fixed dead band, operating range 0-9 PSIG, snap action SPDT switch (15 A, 125 VAC), watertight enclosure, transducer with 0.25 NPT connection, brass with BUNA-N seals.
- Manufacturer:** ASCO
- Mfg. PN:** PB31B/RD30A21
- WesTech PN:** 2-13599/2-16950
- Quantity:** One (1) per assembly
- Tag(s):** PS-102, PS-202
- Description:** Pressure Gauge, compound special range, left vacuum 0-30 Hg & 0-34 feet water, right pressure 0-15 PSIG & 0-34 feet water, 3.50 dial, 0.25 inch NPT bottom connection, wall mount bracket.
- Manufacturer:** ASHCROFT
- Mfg. PN:** 35-1009AW-02L-XFW-[30/0/15PSIG AND 34 FT WATER VAC/0/34FT WATER]
- WesTech PN:** 2-13401
- Quantity:** One (1) per assembly
- Tag(s):** PI-101, PI-201

REV	REVISION DESCRIPTION	ECN	DESIGNER	APPROVER	DATE
THIS DRAWING IS PROPERTY OF WESTECH ENGINEERING, INC. AND IS TRANSMITTED IN CONFIDENCE. NEITHER RECEIPT NOR POSSESSION CONFERS OR TRANSFERS ANY RIGHTS TO REPRODUCE, USE, OR DISCLOSE IN WHOLE OR IN PART, DATA CONTAINED HEREIN FOR ANY PURPOSE WITHOUT THE WRITTEN PERMISSION OF WESTECH ENGINEERING, INC.					
DESIGNER	RE60	<b>CATALOG &amp; BULLETIN INFORMATION</b> <b>PRESSURE SWITCHES AND ACCESSORIES</b> <b>MT ROSE WATER TREATMENT PLANT</b>			
CHECKER	DA48				
APPROVER	DA48				
DATE	2018-05-03				
FILE: 23414A-DS09-PRESSURE SWITCHES AND ACCESSORIES.docx		PROJECT 23414A	DOCUMENT NUMBER 23414A-DS03	SHEET 1 OF 2	REV -

## CATALOG & BULLETIN INFORMATION

Description: Clarifier Pressure Switch Assembly consisting of one High Pressure Switch, one High-High Pressure Switch and one Pressure Gauge.

Function: Monitor pressure in clarifier below the media and indicate high headloss flush required and to shut down clarifier on high-high pressure to prevent damage to system.

Location: Tap into Adsorption Clarifier side wall below media

WesTech PN: 1-9211

Quantity: Two (2) Assemblies consisting of:

Description: Pressure Switch, P-Series, single stage fixed dead band, operating range 0-9 PSIG, snap action SPDT switch (15 A, 125 VAC), watertight enclosure, transducer with 0.25 NPT connection, brass with BUNA-N seals.

Manufacturer: ASCO

Mfg. PN: PB31B/RD30A21

WesTech PN: 2-13599/2-16950

Quantity: Two (2) per assembly

Tag(s): PSH-110, PSH-210, PSHH-110, PSHH-210

Description: Pressure Gauge, 0-5 PSIG, 2.5 dial, bronze diaphragm, 0.25 NPT bottom connection, painted steel case, brass socket.

Manufacturer: ASHCROFT

Mfg. PN: 25-1490A-02L-0-5 PSI

WesTech PN: 2-11230

Quantity: One (1) per assembly

Tag(s): PI-110, PI-210

REV	REVISION DESCRIPTION	ECN	DESIGNER	APPROVER	DATE
THIS DRAWING IS PROPERTY OF WESTECH ENGINEERING, INC. AND IS TRANSMITTED IN CONFIDENCE. NEITHER RECEIPT NOR POSSESSION CONFERS OR TRANSFERS ANY RIGHTS TO REPRODUCE, USE, OR DISCLOSE IN WHOLE OR IN PART, DATA CONTAINED HEREIN FOR ANY PURPOSE WITHOUT THE WRITTEN PERMISSION OF WESTECH ENGINEERING, INC.					
DESIGNER	RE60	<b>TITLE</b> CATALOG & BULLETIN INFORMATION PRESSURE SWITCHES AND ACCESSORIES MT ROSE WATER TREATMENT PLANT <b>CLIENT</b> TRUCKEE MEADOWS WATER AUTHORITY ~ PO 03422 STANTEC CONSULTING, INC. ~ SPECIFICATION 13160			
CHECKER	DA48				
APPROVER	DA48				
DATE	2018-05-03				
FILE: 23414A-DS09-PRESSURE SWITCHES AND ACCESSORIES.docx		PROJECT 23414A	DOCUMENT NUMBER 23414A-DS03	SHEET 2 OF 2	REV -

## Switches for Vacuum through 6000 psig with Adjustable Set Points and Fixed or Adjustable Deadband

### Features:

- Set point repeatability,  $\pm 1\%$  of operating range.
- All wiring terminals, adjustments and visual scales are accessible from the front of the switch.
- Choice of open frame type, general purpose or watertight enclosure.
- Choice of fixed, limited-adjustable or full-range adjustable deadband.
- Choice of single or two-stage units.
- Compact size.
- Mounts in any position.
- Rugged and vibration resistant; e.g., for compressors.
- Visual adjustment scales in psig and bars.
- Wide selection of transducer wetted materials suitable for air, water, oil or corrosive fluids.
- Mix and match switch and transducer components for increased stock flexibility or to change pressure ranges in field.



### General Description:

ASCO P-Series pressure switches consist of an open frame or enclosure protected switch unit and a transducer unit. They can be ordered separately for customer stocking and/or field assembly or as a complete factory-assembled unit.

### Switch

P-Series pressure switch units incorporate the unique ASCO TRI-POINT alternating fulcrum balance plate to control the operation of one or more electrical snap-action switches. The electrical snap-action switch together with the adjusting mechanism is a fully-tested, self-contained subassembly.

### Transducer

Transducer unit incorporates a diaphragm/piston type pressure sensor, and is also a fully-tested, self-contained subassembly.

### Operation

When pressure is applied to the transducer it is converted into movement of the piston. This piston movement is then used to control the operation of the electrical snap-action switch in the switch unit.

**Options** (See pages 34-35)

### Standard Electrical Ratings

#### PA, PB, PC <sup>①</sup> Series

- 15 Amp Res., 125 VAC
- 10 Amp Res., 250 VAC
- 1/8 HP, 125 VAC
- 1/4 HP, 250 VAC
- 1/2 Amp Res., 125 VDC
- 1/4 Amp Res., 250 VDC

#### PG Series

- 15 Amp Res., 125 VAC
- 10 Amp Res., 250 VAC
- 1/8 HP, 125 VAC
- 1/4 HP, 250 VAC

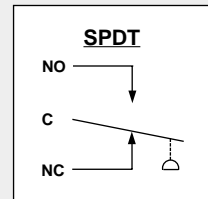

- <sup>①</sup> PC Series, UL recognized component, rated 10 Amp Res., 125/250 VAC; 1/3 HP 125/250 VAC.
- <sup>②</sup> Open frame construction, UL recognized component.
- <sup>③</sup> FM listed for air flow interlocking service.

### Standard Temperature Ratings

- Ambient:** -4°F (-20°C) to 122°F (50°C)
- Fluid:** For Buna "N" or Neoprene Diaphragm
  - 4°F (-20°C) to 180°F (82°C)
  - For Viton Diaphragm
    - 4°F (-20°C) to 250°F (121°C)
    - For 316 SS Diaphragm
      - 50°F (-45°C) to 300°F (149°C)
      - For Nylon Transducers
        - 4°F (-20°C) to 180°F (82°C)

**Enclosures**

ASCO TRI-POINT switches are available in either a general purpose or watertight enclosure, in addition to open frame construction. These enclosed units are made in accordance with NEMA and UL standards. These standards define the protection level an enclosure gives and the tests it must pass to meet a particular design.

**General Purpose** – Type 1. These enclosures are designed for indoor use to protect personnel from accidental contact with the equipment. P-Series general purpose enclosures are painted, zinc-coated

steel and have a 7/8" diameter hole at the top for electrical entry.

**Watertight** – Type 4. Watertight and dust-tight enclosures are intended for use indoors and outdoors to protect the enclosed equipment against splashing or falling water, windblown dust and water, hose directed water, and severe external condensation. P-Series watertight switch enclosures are epoxy-painted, zinc-coated steel with a 1/2" conduit hub in the side of the lower housing for electrical entry. (~~For optional 316 SS watertight enclosure see page 13.~~)

**Dimensions (inches)**

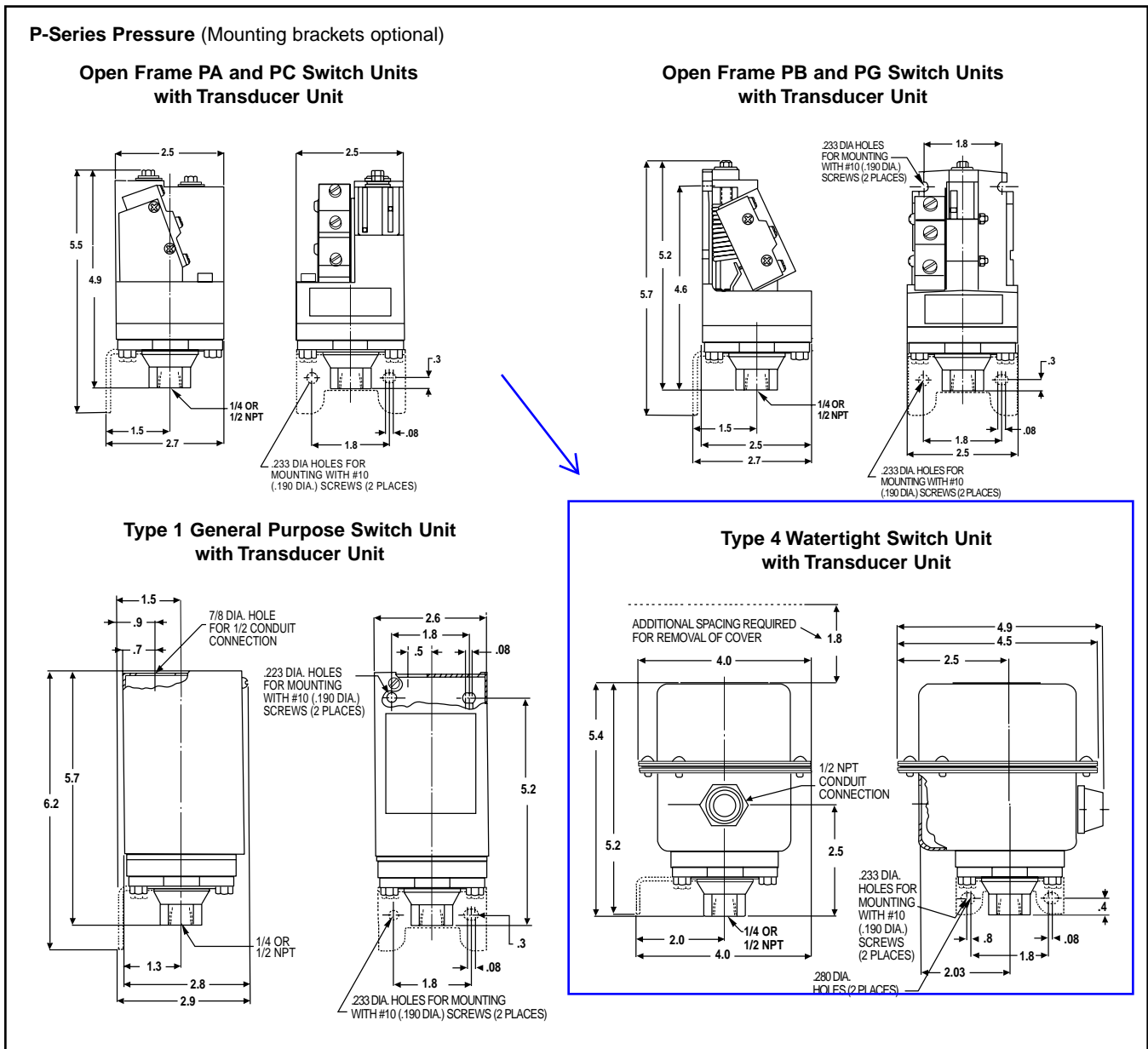

# P-SERIES Pressure Switches



General Purpose Enclosure



Watertight Enclosure

## How to Select and Order

ASCO P-Series switches consist of two components, the switch unit and the transducer unit.

## How to Select

1. Select the adjustable operating range based on desired actuation pressure.
2. Check that proof pressure is sufficient.
3. Read across and select the desired P-Series switch unit with the proper enclosure.
4. Continue across and select a matching transducer unit compatible with the fluid.

## How to Order

**Factory assembled** – Simply order the switch and transducer unit by catalog number joined by a slash (/), e.g., PA36A/RD30A11.

**Field assembled** – Simply order the switch and transducer units separately by individual catalog number, e.g., one PA36A and one RD30A11.

**Options** – Add appropriate suffix for desired option or accessory (see pages 34-35).

**Important Note:** The third digit of each of the catalog numbers must be identical, e.g., PA [3]6A and RD [3]0A11.

## Select transducer unit below



Standard connection is 1/4" NPT  
 (optional 1/2" NPT add suffix "B" to catalog number)

## Transducer Unit

These **gauge pressure type transducers** provide for one pressure connection in the bottom of the transducer. They are diaphragm/piston type transducers using an elastomer in contact with the fluid, backed by a piston cylinder. This allows high sensitivity for low pressures and strength for high pressures.

PA, PB, or PC unit below											
PA Switch Unit			PB Switch Unit						PC Switch Unit		
<b>Single-Stage Adjustable Deadband</b> units allow independent adjustment of the set and reset points over the full operating range of the switch. The minimum difference between set and reset points is the deadband listed below; the maximum difference is the full range of the switch.			<b>Single-Stage Fixed Deadband</b> units have an adjustable set point and a non-adjustable automatic reset point.						<b>Two-Stage Fixed Deadband</b> units consist of two separate snap-action switches, each with an independently adjustable set point and non-adjustable reset point. The difference between the set and reset points of each switch is the deadband listed below; the minimum difference between the set points of the two switches is the separation.		
Open Frame			Open Frame						Open Frame		

Specifications		Adjustable Deadband				Fixed Deadband				Two-Stage Fixed Deadband				Transducer Units							
Adjustable Operating Range (psig)	Proof Pressure (psig)	Adjustable Deadband Maximum Full Scale	Open Frame	General Purpose	Watertight Enclosure	Fixed Deadband At Mid-Range (psig) ⊙	Open Frame	General Purpose	Watertight Enclosure	Fixed Deadband At Mid-Range (psig) ⊙	Separation		Open Frame	General Purpose	Watertight Enclosure	Air or Gas ⊕	Air, Oil or Gas	Water, Air, Oil or Gas	Corrosive Fluids		
											Minimum At Mid-Range (In W.C.) ⊙	Catalog No.				Catalog No.	Catalog No.	Maximum Full Scale	Minimum At Mid-Range (psig) ⊙	Catalog No.	Catalog No.
Vacuum																					
0 - 30" Hg	50	4" Hg	PA36A	PA30A	PA31B	1" Hg	PB36A	PB30A	PB31B	2.7" Hg	3" Hg	PC36A	PC30A	PC31B	---	RV34A11	RV34A21	---	---	RV34A32	
Compound 30"Hg - 14 psig Pressure	50	6" Hg	PA26A	PA20A	PA21B	1" Hg	PB26A	PB20A	PB21B	4.3" Hg	6" Hg	PC26A	PC20A	PC21B	---	RV24A11	RV24A21	---	---	RV24A32	
0 - 4	60	---	---	---	---	0.05	PB46A	PB40A	PB41B	---	---	---	---	---	RD40A71	RD40A11	RD40A21	---	---	RD40A42	
0 - 9	60	1.2	PA36A	PA30A	PA31B	0.4	PB36A	PB30A	PB31B	0.6	1.0	PC36A	PC30A	PC31B	RD36A71	RD36A11	RD36A21	---	---	RD30A42	
2 - 18	60	1.8	PA26A	PA20A	PA21B	0.4	PB26A	PB20A	PB21B	0.8	1.8	PC26A	PC20A	PC21B	RD20A71	RD20A11	RD20A21	---	---	RD20A42	
2 - 18	100	2.5	PA36A	PA30A	PA31B	0.6	PB36A	PB30A	PB31B	1.2	1.8	PC36A	PC30A	PC31B	---	---	---	RE30A44	---	---	
4 - 36	150	4.0	PA26A	PA20A	PA21B	0.7	PB26A	PB20A	PB21B	2.0	3.6	PC26A	PC20A	PC21B	RE20A71	RE20A11	RE20A21	RE20A44	RE20A42	RE20A42	
6 - 60	150	5.4	PA16A	PA10A	PA11B	0.9	PB16A	PB10A	PB11B	2.4	6.0	PC16A	PC10A	PC11B	RE10A71	RE10A11	RE10A21	RE10A44	RE10A42	RE10A42	
10 - 100	200	9	PA16A	PA10A	PA11B	1.5	PB16A	PB10A	PB11B	4	10	PC16A	PC10A	PC11B	RF10A71	RF10A11	RF10A21	RF10A44	RF10A42	RF10A42	
20 - 200	400	18	PA16A	PA10A	PA11B	3.0	PB16A	PB10A	PB11B	8	20	PC16A	PC10A	PC11B	RG10A71	RG10A11	RG10A21	RG10A44	RG10A42	RG10A42	
30 - 300	450	27	PA16A	PA10A	PA11B	5.0	PB16A	PB10A	PB11B	12	30	PC16A	PC10A	PC11B	---	RH10A11	RH10A21	RH10A44	RH10A42	RH10A42	
40 - 400	500	36	PA16A	PA10A	PA11B	6	PB16A	PB10A	PB11B	16	40	PC16A	PC10A	PC11B	---	RJ10A11	RJ10A21	RJ10A44	RJ10A42	RJ10A42	
60 - 600	2000	54	PA26A	PA20A	PA21B	12	PB26A	PB20A	PB21B	30	60	PC26A	PC20A	PC21B	---	---	RL20A21	---	---	RL20A42	
100 - 1000	2000	90	PA16A	PA10A	PA11B	15	PB16A	PB10A	PB11B	40	100	PC16A	PC10A	PC11B	---	---	RL10A21	---	---	RL10A42	
160 - 1650	5000	250	PA26A	PA20A	PA21B	100	PB26A	PB20A	PB21B	200	300	PC26A	PC20A	PC21B	---	---	RN20B21	---	---	RN20B42	
270 - 2700	5000	300	PA16A	PA10A	PA11B	125	PB16A	PB10A	PB11B	250	400	PC16A	PC10A	PC11B	---	---	RN10B21	---	---	RN10B42	
600 - 6000	9000	650	PA16A	PA10A	PA11B	200	PB16A	PB10A	PB11B	400	600	PC16A	PC10A	PC11B	---	---	---	---	---	RQ10B42	

All switch units above are in stock for immediate delivery.

All switch units and transducer units above are in stock for immediate delivery.

⊕ Values shown are nominal. ⊙ Rated proof pressure on RF10A71 is 150 psig and on RG10A71 is 300 psig.

⊕ 316 SS transducer deadbands are approx. 50% greater than listed. ⊙ Transducers ending in 32 have 303 SS process connections, not 316 SS.

**STANTEC  
THIS PAGE ONLY  
NO EXCEPTION TAKEN**

This Page Intentionally Blank

## Type 1009AW Stainless Case Gauge with Bronze System



### FEATURES

- Patented PowerFlex™ movement
- All welded construction
- True Zero™ pointer indication
- NEW ventable plug
- NEW patent pending through-dial calibration
- NEW MSL helium leak tested to  $1 \times 10^{-6}$  ATM - cc/sec
- Meets ASME B40.100 standard
- RoHS compliant
- CRN approved
- 5 year limited warranty

Ashcroft is pleased to reintroduce the 1009AW Duralife® pressure gauge. This gauge has been upgraded with many new features outlined above while maintaining the tried and true performance and quality you have come to expect.

Duralife 1009AW gauges provide significant features and benefits. New features include a ventable plug that can be sealed or vented depending on your environment and a patent pending through-dial recalibration that reduces recalibration time.

The combination of features including the patented PowerFlex™ movement and optional PLUS!™ Performance dampening system in the 1009AW is the finest gauge technology for vibration, shock and pulsation applications. Available in pressure ranges from vacuum to 1000 psi, including compound and metric ranges.

### PRODUCT SPECIFICATIONS

<b>Ashcroft Type No.:</b>	1009AW
<b>Sizes:</b>	2½", 3½"
<b>Case:</b>	304SS
<b>Ring:</b>	304SS polished bayonet
<b>Window:</b>	Polycarbonate
<b>Dial:</b>	Black figures on white background, aluminum
<b>Pointer:</b>	Friction adjust, black, aluminum
<b>Bourdon Tube:</b>	316L stainless steel C-Shaped (vacuum-600 psi and compound) Helical (1000psi)
<b>Socket:</b>	Bronze
<b>Movement:</b>	300 series stainless steel, PowerFlex, polyester segment, overload/underload stops
<b>Connections:</b>	¼ and ½ NPT, lower or lower back
<b>Ranges:</b>	Vac-1000 psi and compound
<b>Accuracy:</b>	1% full scale; ASME Grade 1A <sup>(1)</sup>
<b>Fill Plug:</b>	Ventable
<b>Protection:</b>	Nema 4X / IP65 plug sealed Nema 3 / IP54 plug vented
<b>Ambient Temperature Limitations:</b>	-40°F to 200°F dry +20°F to 150°F glycerin filled -40°F to 150°F silicone filled (based on standard polycarbonate window)
<b>OPTIONAL FEATURES</b>	
<b>Liquid fill:</b>	Glycerin, silicone, halocarbon (includes throttle plug)
<b>Dampening:</b>	PLUS!™ Performance (LL) (includes throttle plug)
<b>Window:</b>	Safety glass (SG)
<b>Pointer:</b>	Micrometer (MP)
<b>Connections:</b>	Metric and SAE on request
<b>Mounting:</b>	U-clamp (UC), Front flange (FF), Back flange (FW)
<b>Dials:</b>	Receiver ranges, refrigerant ranges; custom dials

<sup>(1)</sup>When these gauges are liquid filled the total gauge accuracy may be as much as 1.5%

### HOW TO ORDER (Typical example) 35-1009AW-02L-XFW-[30/0/15PSIG AND 34 FT WATER VAC/0/34FT WATER]

**Dial Size:** 2½" (25), 3½" (35) \_\_\_\_\_

**Case Type:** 1009 \_\_\_\_\_

**Tube and Socket Material:** 316L SS & Bronze \_\_\_\_\_

**Liquid Filled:** (glycerin) leave blank if dry \_\_\_\_\_

**Connection Size:** ¼ (01), ½ (02) \_\_\_\_\_

**Connection Location:** Lower (L), Lower Back (B) \_\_\_\_\_

**Options:** \_\_\_\_\_

**Range:** 0/100 psi \_\_\_\_\_

# Type 1009AW Stainless Case Gauge with Bronze System

## DIMENSIONS

**2 1/2" 1009 Lower and Back Connect**

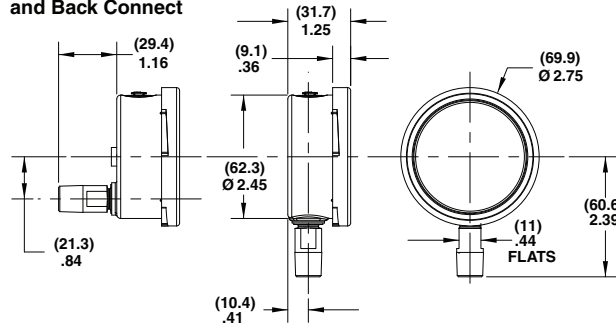

**3 1/2" 1009 Lower and Back Connect**

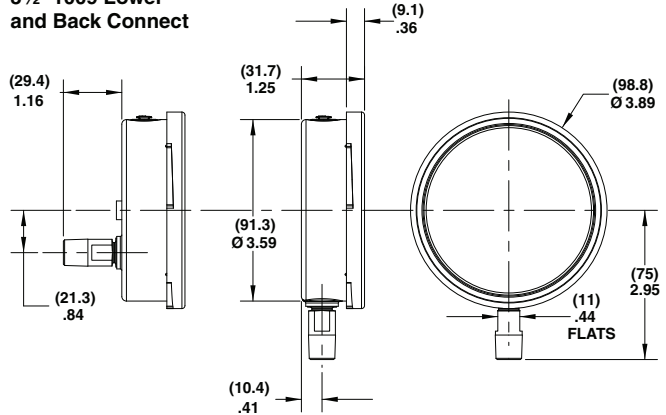

**2 1/2" 1009 Back Connect (XUC)**

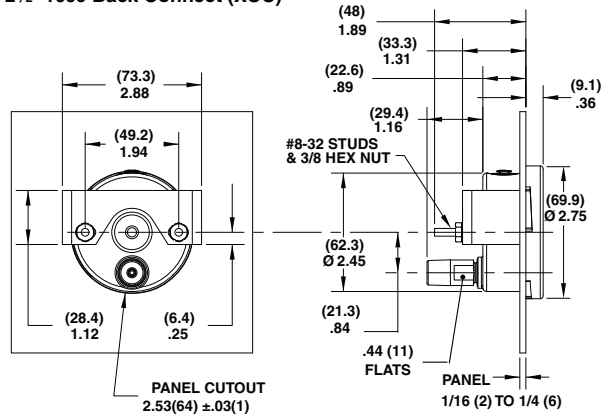

**3 1/2" 1009 Back Connect (XUC)**

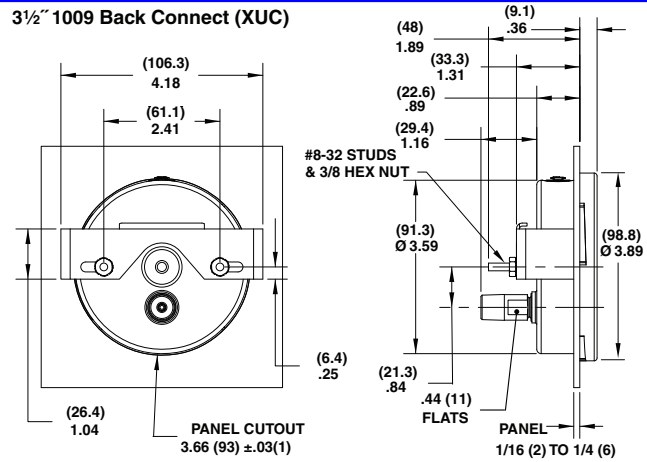

**2 1/2" 1009 Back Connect (XFF)**

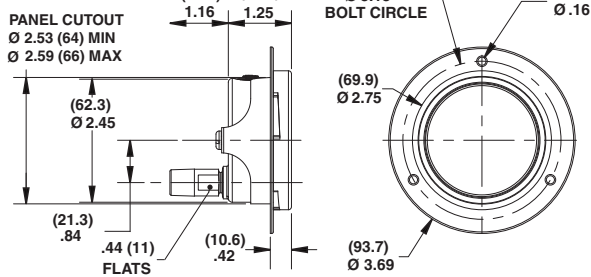

**3 1/2" 1009 Back Connect (XFF)**

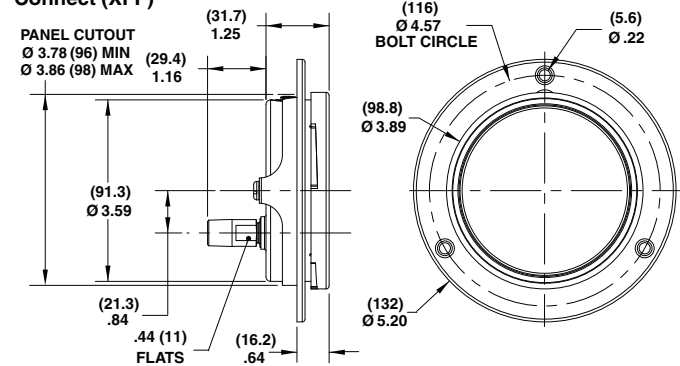

**2 1/2" 1009 Lower and Back Connect (XFW)**

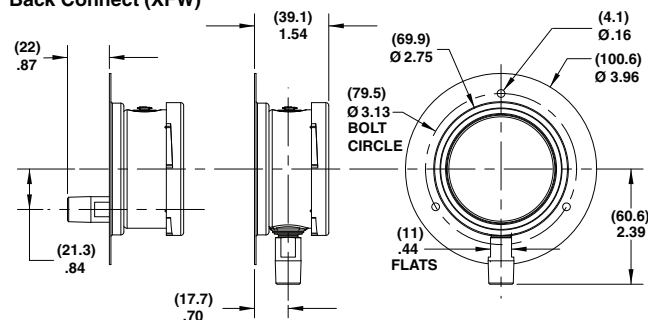

**3 1/2" 1009 Lower and Back Connect (XFW)**

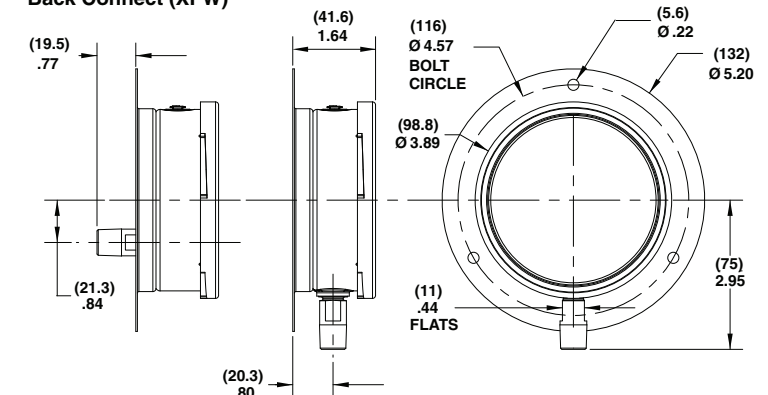

## Process, Stainless Steel, Test and Industrial Pressure Gauge Options

CODE	DESCRIPTION	PRESSURE GAUGE TYPE							
		DURAGAUGE GAUGES	STAINLESS STEEL CASE			TEST GAUGES	INDUSTRIAL GAUGE		
			1009 (2 1/2", 3 1/2")	1009 (4 1/2", 6")	1008S		GENERAL SERVICE	SPECIAL SERVICE	1490/1495 SERIES
									
XLL	<b>PLUS!</b> Performance	●	●		● <sup>(1)</sup>				
XNS	<b>PLUS!</b> Performance – Silicone Free	●	●		●				
XBF	Wall mounting bracket			●					
XFW	Back flange		●						
XFF	Front flange		●		●				
XUC	U-clamp		●	●				●	●
XLJ	Dry liquid-fillable gauge	●	●	●	●				
XOS	Overload stop	●	STD	●	STD <sup>(1)</sup>	STD	●	●	
XVS	Underload stop	●	STD	●	STD <sup>(1)</sup>	STD	●	●	
XTS	Throttle screw	●		●		●	●	●	
XTU	Throttle plug		●		●				●
XS4	Slotted link movement (decrease)	●		●			●	●	
XRJ	Slotted link (increase)	●		●			●	●	
XAP	Adjustable pointer		●	●			●	●	
XMP	Micrometer pointer	STD	●	●			●	●	
XSH	Red set hand stationary	●	●	●			●	●	
XEO	Red set hand adjustable	●	●	●		●	●	●	●
XEP	Maximum pointer	●		●		●	●	●	
XEQ	Minimum pointer	●		●		●	●	●	
XPD	Plastic window	●	STD		STD <sup>(2)</sup>	●	●	●	STD
XSG	Safety glass	●	●	●		●	●	●	
XMG	Metric version gauge		●		●				
XRG	Regular glass	STD		STD		STD	STD	STD	
XDA	Dial marking	●	●	●	●	●	●	●	●
XNN	Paper tag	●	●	●	●	●	●	●	●
XNH	Stainless steel tag	●	●	●	●	●	●	●	●
XAB	Absolute pressure	●		●			●		
XAJ	1/2% optional accuracy	STD		●			●	●	
XAN	1% optional accuracy		STD	STD			STD		●
XRA	Retard scale	●		●			●		
XWN	White dial	STD	●	●	STD	STD	●	●	STD
XBD	Black dial	●	●	●	●	●	●	●	●
X6B	Oxygen-cleaned gauges (gaseous)	●	●	●	●	●	●	●	
XTB	Tip bleed	●				●			
XED	High and low electric contacts	●							
XEE	Double high-electric contacts	●							
XEF	Double low-electric contacts	●							
XEG	Electric contacts off at low or high and in-between	●							
XGV	Silicone-filled gauge	●	●	●	●				
XGX	Halocarbon-filled gauge	●	●	●	●				
XCH	Carrying handle					●			
XC4	Calibration Chart	●	●	●	●	●	●	●	●

### NOTES:

The options listed above are only a partial listing.  
For other options on these or other pressure instruments  
please call the factory for availability.

(1) Available on 63mm and 100mm.

(2) Available on 40mm and 50mm.

## Type 1490 Low Pressure Diaphragm Gauge



- *Glass-filled polysulfone case material, won't rust or dent*
- *Beryllium copper diaphragm*
- *Brass socket*
- *Wetted materials of beryllium copper, brass, polysulfone and RTV silicone*

The Ashcroft® Type 1490 low pressure diaphragm gauge is designed to measure pressure from 10 in. H<sub>2</sub>O to 15 psi, both positive and negative pressures. This gauge uses a very sensitive diaphragm capsule to measure low pressure and vacuum. The gauge is specifically designed for use whenever the pressure medium is a gas that is not corrosive to beryllium copper, brass, polysulfone and RTV silicone. The polysulfone case is suitable for intermittent or continuous service on natural gas provided a .013 throttle plug is installed in the socket. Typical applications are, but not limited to, vacuum pumps, gas leak detectors, air compressors, air filters, gas burners, gas measurement, vacuum ovens, suction regulators and respirators.

### PRODUCT SPECIFICATIONS

<b>Model Number:</b>	1490
<b>Accuracy:</b>	±2-1-2% full scale (Grade A, ASME B40.100)
<b>Ranges:</b>	10 in. H <sub>2</sub> O through 15 psi including vac. and compound
<b>Dial Size:</b>	2½" and 3½" diameter
<b>Case Material:</b>	Black, glass filled polysulfone
<b>Socket Material:</b>	Brass
<b>Movement:</b>	Brass
<b>Sensing Element:</b>	Beryllium copper diaphragm
<b>Wetted Material:</b>	Beryllium copper, brass, polysulfone and RTV silicone
<b>Window:</b>	Polycarbonate, quarter turn bayonet style mounting
<b>Dial:</b>	Aluminum, white background, black figures and intervals.
<b>Pointer:</b>	Black, aluminum, fixed
<b>Connection Size:</b>	1/8" NPT (01) 1/4" NPT (02) ← 1/8" tubing hose barb (HD) 3/16" tubing hose barb (HE) 1/4" tubing hose barb (HF) 1/4" O.D. polytube hose barb (HG) 10-32 2B female thread (HH)
<b>Connection Location:</b>	Lower (L) ← Center Back (B) Top (T) 3 o'clock (D) 9 o'clock (E)
<b>Operating Temperature:</b>	-20 to 180°F
<b>Proof Pressure:</b>	150% of range
<b>Burst Pressure:</b>	Up to 5 psi = 50 psi Greater than 5 psi = 100 psi

### OPTIONAL FEATURES

<b>1% Accuracy:</b>	<del>XAN</del>
<b>Dial Marking:</b>	<del>XDA</del>
<b>Stainless Steel Tag:</b>	<del>XNH</del>
<b>Paper Tag:</b>	<del>XNN</del>
<b>Throttle Plug:</b> <sup>(1)(3)</sup>	<del>XTU</del>
<b>Throttle Screw:</b> <sup>(4)</sup>	<del>XTS</del>
<b>U-clamp:</b> <sup>(2)</sup>	<del>XUC</del>
<b>FlutterGuard™:</b>	<del>XZY</del>

- (1) A throttle plug must be installed in the socket whenever the gauge is used for intermittent or continuous service on natural gas.  
 (2) U-clamp furnished when hose barb or female thread is specified.  
 (3) Throttle plug not available with hose barb or female thread connections.  
 (4) .020 throttle screw available with HH connection only.

## Type 1490 Low Pressure Diaphragm Gauge

### STANDARD RANGES

Pressure	Figure Intervals	Minor Graduation
0/10 in.H <sub>2</sub> O	1	0.1
0/15 in.H <sub>2</sub> O	5	0.2
0/30 in.H <sub>2</sub> O	5	0.5
0/60 in.H <sub>2</sub> O	10	1
0/100 in.H <sub>2</sub> O	10	1
0/160 in.H <sub>2</sub> O	20	2
0/200 in.H <sub>2</sub> O	20	2
0/300 in.H <sub>2</sub> O	50	5
0/10 oz./in. <sup>2</sup>	1	0.1
0/15 oz./in. <sup>2</sup>	5	0.2
0/30 oz./in. <sup>2</sup>	5	0.5
0/60 oz./in. <sup>2</sup>	10	1
0/100 oz./in. <sup>2</sup>	10	1
0/160 oz./in. <sup>2</sup>	20	2
0/250 oz./in. <sup>2</sup>	50	5
0/3 psi	0.5	0.05
0/5 psi	1	0.1
0/10 psi	1	0.1
0/15 psi	5	0.2

### STANDARD RANGES (Cont.)

Vacuum	Figure Intervals	Minor Graduation			
15/0 in.H <sub>2</sub> O	5	0.2			
30/0 in.H <sub>2</sub> O	5	0.5			
60/0 in.H <sub>2</sub> O	10	1			
100/0 in.H <sub>2</sub> O	10	1			
200/0 in.H <sub>2</sub> O	20	2			
15/0 oz./in. <sup>2</sup>	5	0.2			
30/0 oz./in. <sup>2</sup>	5	0.5			
60/0 oz./in. <sup>2</sup>	10	1			
100/0 oz./in. <sup>2</sup>	10	1			
<b>Compound</b>					
-30/30 in.H <sub>2</sub> O	10	1			
-30/30 in.oz./in. <sup>2</sup>	10	1			
-10/10 in.H <sub>2</sub> O	2	0.2			
<b>Dual Scale</b>					
Range		Graduations			
		Inner Scale		Outer Scale	
Inner Scale	Outer Scale	Figure Intervals	Minor Grad.	Figure Intervals	Minor Grad.
0/9 oz./in. <sup>2</sup>	0/15 in.H <sub>2</sub> O	1	0.2	5	0.2
0/20 oz./in. <sup>2</sup>	0/35 in.H <sub>2</sub> O	5	0.5	5	0.5
0/35 oz./in. <sup>2</sup>	0/60 in.H <sub>2</sub> O	5	0.5	10	1
0/60oz./in. <sup>2</sup>	0/100 in.H <sub>2</sub> O	10	1	10	1

### STANDARD METRIC RANGES

Pressure	Figure Intervals	Minor Graduation
0/60 cm. H <sub>2</sub> O	10	1
0/2.5 kPa	0.5	0.05
0/4 kPa	1	0.1
0/10 kPa	1	0.1
0/16 kPa	2	0.2
0/25 kPa	5	0.5
0/40 kPa	10	1
0/100 kPa	10	1
<b>Vacuum</b>		
2.5/0 kPa	0.5	0.05
4/0 kPa	1	0.1
10/0 kPa	1	0.1
16/0 kPa	2	0.2
25/0 kPa	5	0.5
40/0 kPa	10	1
100/0 kPa	10	1
<b>Compound</b>		
-10/60 cm H <sub>2</sub> O	10	1
-10/80 cm H <sub>2</sub> O	10	1
-20/40 cm H <sub>2</sub> O	10	1
-10/100 cm H <sub>2</sub> O	10	1
-10/120 cm H <sub>2</sub> O	20	2

Other ranges available on request. Consult factory.

### SELECTION TABLE

Dial Size		Type		Wetted Material		Conn. Size & Type		Connection Location		Ranges		Optional Features	
Code	Desc.	Code	Description	Code	Description	Code	Description	Code	Description	Code	Description	Code	Description
25	2 1/2"	1490	Low Pressure Diaphragm Gauge	A	Beryllium Copper	01	1/8" NPT	L	Lower	10 IW	0 to 10 in.H <sub>2</sub> O	XAN	1% Opt. Accuracy
35	3 1/2"				Brass	02	1/4" NPT	B	Center Back			XDA	Dial Marking
					Polysulfone	HD	1/8" I.D. Tubing Hose Barb <sup>(2,3)</sup>	T	Top			XNH	Stain. Steel Tag
					RTV Silicone	HE	3/16" I.D. Tubing Hose Barb <sup>(2,3)</sup>	D	3 O'Clock			XNN	Paper Tag
						HF	1/4" I.D. Tubing Hose Barb <sup>(2,3)</sup>	E	9 O'Clock			XTU <sup>(1,3)</sup>	Throttle Plug
						HG	1/4" O.D. Polytube Hose Barb <sup>(2,3)</sup>					XTS <sup>(4)</sup>	Throttle Screw
						HH	10-32-2B Female Thread <sup>(2,3,5)</sup>					XUC <sup>(2)</sup>	U-clamp
							XZY	FlutterGuard™					

- (1) A throttle plug must be installed in the socket whenever the gauge is used for intermittent or continuous service on natural gas.  
 (2) U-clamp furnished when hose barb or female thread is specified.  
 (3) Throttle plug not available with hose barb or female thread connections.  
 (4) .020 throttle screw available with HH connection only.

### 35-1490A-02L-0-5PSI

#### HOW TO ORDER:

25    1490    A    02L    XXX    10 IW

- Dial size – 2 1/2 (25), 3 1/2 (35) \_\_\_\_\_
- Case type \_\_\_\_\_
- Wetted material \_\_\_\_\_
- Connection size – 1/4 (02), 1/8 (01) \_\_\_\_\_
- Connection location – Lower (L), Back (B) \_\_\_\_\_
- Optional features \_\_\_\_\_
- Standard pressure range – 10 in.H<sub>2</sub>O \_\_\_\_\_

## Type 1490 Low Pressure Diaphragm Gauge

### DIMENSIONS

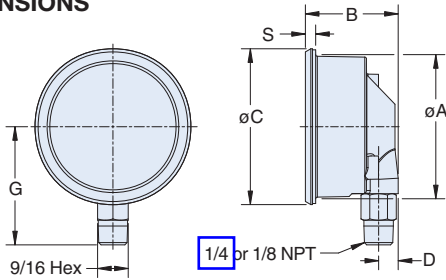

Size	øA	B	øC	D	G	S
25	2 <sup>19</sup> / <sub>32</sub> (66)	1 <sup>23</sup> / <sub>32</sub> (44)	2 <sup>7</sup> / <sub>8</sub> (73)	3/ <sub>10</sub> (10)	2 <sup>9</sup> / <sub>16</sub> (55)	1 <sup>3</sup> / <sub>64</sub> (5)
35	3 <sup>2</sup> / <sub>32</sub> (93)	1 <sup>1</sup> / <sub>16</sub> (43)	3 <sup>3</sup> / <sub>32</sub> (101)	3/ <sub>10</sub> (10)	2 <sup>23</sup> / <sub>32</sub> (69)	1 <sup>3</sup> / <sub>64</sub> (5)

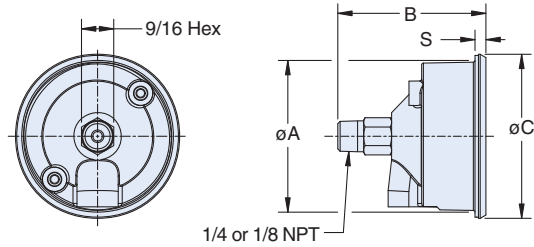

Size	øA	B	øC	S
25	2 <sup>19</sup> / <sub>32</sub> (66)	2 <sup>19</sup> / <sub>32</sub> (66)	2 <sup>7</sup> / <sub>8</sub> (73)	1 <sup>3</sup> / <sub>64</sub> (5)
35	3 <sup>2</sup> / <sub>32</sub> (93)	2 <sup>9</sup> / <sub>16</sub> (65)	3 <sup>3</sup> / <sub>32</sub> (101)	1 <sup>3</sup> / <sub>64</sub> (5)

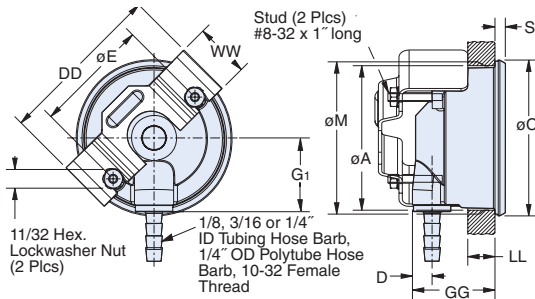

Size	øA	øC	D	øE	G				G1	øM	S	DD	GG	LL Max.	WW
					1/2 ID Tubing	3/4 ID Tubing	1/4 ID Tubing	1/4 OD Tubing	10-32 Female						
25	2 <sup>19</sup> / <sub>32</sub> (66)	2 <sup>7</sup> / <sub>8</sub> (73)	3/ <sub>10</sub> (10)	2 <sup>1</sup> / <sub>8</sub> (54)	1 <sup>3</sup> / <sub>4</sub> (44)	2 <sup>1</sup> / <sub>8</sub> (54)	2 <sup>9</sup> / <sub>32</sub> (54)	1 <sup>3</sup> / <sub>4</sub> (44)	1 <sup>1</sup> / <sub>2</sub> (34)	2 <sup>2</sup> / <sub>32</sub> (67)	1 <sup>9</sup> / <sub>64</sub> (5)	3 <sup>1</sup> / <sub>16</sub> (78)	1 <sup>19</sup> / <sub>32</sub> (40)	1/2 (13)	1 (25)
35	3 <sup>2</sup> / <sub>32</sub> (93)	3 <sup>3</sup> / <sub>32</sub> (101)	3/ <sub>10</sub> (10)	3 <sup>3</sup> / <sub>16</sub> (67)	2 <sup>5</sup> / <sub>16</sub> (59)	2 <sup>2</sup> / <sub>32</sub> (81)	2 <sup>1</sup> / <sub>16</sub> (54)	2 <sup>5</sup> / <sub>16</sub> (59)	1 <sup>3</sup> / <sub>32</sub> (50)	3 <sup>3</sup> / <sub>4</sub> (95)	1 <sup>9</sup> / <sub>64</sub> (5)	4 <sup>1</sup> / <sub>8</sub> (105)	1 <sup>17</sup> / <sub>32</sub> (39)	1/2 (13)	1 (25)

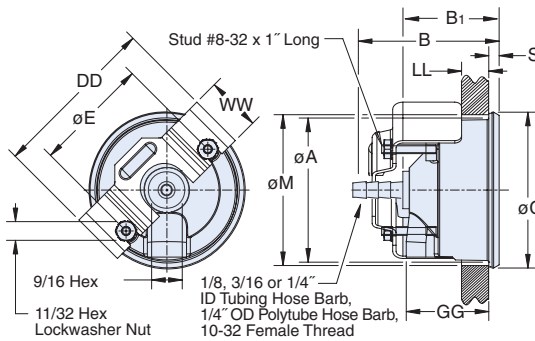

Size	øA	B				B1	øC	øE	øM	S	DD	GG	LL Max.	WW
		1/2 ID Tubing	3/4 ID Tubing	1/4 ID Tubing	1/4 OD Tubing	10-32 Female								
25	2 <sup>19</sup> / <sub>32</sub> (66)	2 <sup>3</sup> / <sub>16</sub> (55)	2 <sup>17</sup> / <sub>32</sub> (64)	2 <sup>11</sup> / <sub>16</sub> (68)	2 <sup>3</sup> / <sub>16</sub> (55)	1 <sup>25</sup> / <sub>32</sub> (45)	2 <sup>7</sup> / <sub>8</sub> (73)	2 <sup>1</sup> / <sub>8</sub> (54)	2 <sup>2</sup> / <sub>32</sub> (67)	1 <sup>3</sup> / <sub>64</sub> (5)	3 <sup>1</sup> / <sub>16</sub> (78)	1 <sup>19</sup> / <sub>32</sub> (40)	1/2 (13)	1 (25)
35	3 <sup>2</sup> / <sub>32</sub> (93)	2 <sup>1</sup> / <sub>8</sub> (54)	2 <sup>1</sup> / <sub>2</sub> (63)	2 <sup>2</sup> / <sub>32</sub> (67)	2 <sup>1</sup> / <sub>8</sub> (54)	1 <sup>23</sup> / <sub>32</sub> (44)	3 <sup>3</sup> / <sub>32</sub> (101)	3 <sup>3</sup> / <sub>16</sub> (81)	3 <sup>3</sup> / <sub>4</sub> (95)	1 <sup>3</sup> / <sub>64</sub> (5)	4 <sup>1</sup> / <sub>8</sub> (105)	1 <sup>17</sup> / <sub>32</sub> (39)	1/2 (13)	1 (25)

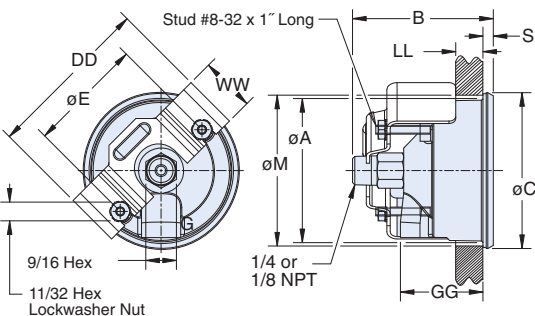

### U-clamp Option

Size	øA	B	øC	øE	øM	S	DD	GG	LL MAX	WW
25	2 <sup>19</sup> / <sub>32</sub> (66)	2 <sup>19</sup> / <sub>32</sub> (66)	2 <sup>7</sup> / <sub>8</sub> (73)	2 <sup>1</sup> / <sub>8</sub> (54)	2 <sup>2</sup> / <sub>32</sub> (67)	1 <sup>3</sup> / <sub>64</sub> (5)	3 <sup>1</sup> / <sub>16</sub> (78)	1 <sup>19</sup> / <sub>32</sub> (40)	1/2 (13)	1 (25)
35	3 <sup>2</sup> / <sub>32</sub> (93)	2 <sup>9</sup> / <sub>16</sub> (65)	3 <sup>3</sup> / <sub>32</sub> (101)	3 <sup>3</sup> / <sub>16</sub> (81)	3 <sup>3</sup> / <sub>4</sub> (95)	1 <sup>3</sup> / <sub>64</sub> (5)	4 <sup>1</sup> / <sub>8</sub> (105)	1 <sup>17</sup> / <sub>32</sub> (39)	1/2 (13)	1 (25)

# CATALOG & BULLETIN INFORMATION

## LEVEL TRANSMITTER

Description: Ultrasonic Level Transmitter, range: 0.8 to 16 feet, Mounting: Thread ANSI NPT1-1/2, PVDF, Housing: F12 Aluminum, coated, IP68 NEMA6P, Power Supply/Output: 2-wire; 4-20mA HART, 14-36 VDC loop power, Cable Entry: Thread NPT1/2.

Manufacturer: Endress and Hauser  
 Model: Prosonic M FMU40  
 MFGR PN: FMU40-ANB2A4  
 WesTech PN: 2-9786

Function: Filter Level indication and control  
 Location: Filter Cell  
 Quantity: Two (2) [One unit]  
 Tag(s): LE/LIT-101, LE/LIT-201

Function: Tube Level indication and control  
 Location: Tube Section  
 Quantity: Two (2) [One unit]  
 Tag(s): LE/LIT-XXX, LE/LIT-XXX (no tags specified in plan drawings)

REV	REVISION DESCRIPTION	ECN	DESIGNER	APPROVER	DATE
THIS DRAWING IS PROPERTY OF WESTECH ENGINEERING, INC. AND IS TRANSMITTED IN CONFIDENCE. NEITHER RECEIPT NOR POSSESSION CONFERS OR TRANSFERS ANY RIGHTS TO REPRODUCE, USE, OR DISCLOSE IN WHOLE OR IN PART, DATA CONTAINED HEREIN FOR ANY PURPOSE WITHOUT THE WRITTEN PERMISSION OF WESTECH ENGINEERING, INC.					
DESIGNER	RE60	TITLE <b>CATALOG &amp; BULLETIN INFORMATION</b> <b>LEVEL TRANSMITTER</b> <b>MT ROSE WATER TREATMENT PLANT</b> CLIENT TRUCKEE MEADOWS WATER AUTHORITY ~ PO 03422 STANTEC CONSULTING, INC. ~ SPECIFICATION 13160			
CHECKER	DA48				
APPROVER	DA48				
DATE	2018-05-03				
FILE: 23414A-DS10-LEVEL TRANSMITTERS.docx		PROJECT 23414A	DOCUMENT NUMBER 23414A-DS10	SHEET 1 OF 2	REV -

# CATALOG & BULLETIN INFORMATION

This Page Intentionally Blank

REV	REVISION DESCRIPTION	ECN	DESIGNER	APPROVER	DATE
THIS DRAWING IS PROPERTY OF WESTECH ENGINEERING, INC. AND IS TRANSMITTED IN CONFIDENCE. NEITHER RECEIPT NOR POSSESSION CONFERS OR TRANSFERS ANY RIGHTS TO REPRODUCE, USE, OR DISCLOSE IN WHOLE OR IN PART, DATA CONTAINED HEREIN FOR ANY PURPOSE WITHOUT THE WRITTEN PERMISSION OF WESTECH ENGINEERING, INC.					
DESIGNER	RE60	<b>TITLE</b> CATALOG & BULLETIN INFORMATION LEVEL TRANSMITTER MT ROSE WATER TREATMENT PLANT  <b>CLIENT</b> TRUCKEE MEADOWS WATER AUTHORITY ~ PO 03422 STANTEC CONSULTING, INC. ~ SPECIFICATION 13160			
CHECKER	DA48				
APPROVER	DA48				
DATE	2018-05-03				
FILE: 23414A-DS10-LEVEL TRANSMITTERS.docx		PROJECT 23414A	DOCUMENT NUMBER 23414A-DS10	SHEET 2 OF 2	REV -

**STANTEC**  
**THIS PAGE ONLY**  
**NO EXCEPTION TAKEN**

# Technical Information

## Prosonic M

### ~~FMU40, FMU41, FMU42,~~ ~~FMU43, FMU44~~

#### Ultrasonic Level Measurement

Compact transmitters for non-contact level measurement



#### Application

- Continuous, non-contact level measurement in fluids, pastes, sullages and coarse bulk materials
- Flow measurement in open channels and measuring weirs
- System integration via:
  - HART (standard), 4 to 20mA
  - ~~PROFIBUS PA~~
  - ~~FOUNDATION Fieldbus~~
- Maximum measuring range:
  - FMU40: 5 m (16 ft) in fluids, 2 m (6.6 ft) in bulk materials
  - ~~FMU41: 8 m (26 ft) in fluids, 3,5 m (11 ft) in bulk materials~~
  - ~~FMU42: 10 m (33 ft) in fluids, 5 m (16 ft) in bulk materials~~
  - ~~FMU43: 15 m (49 ft) in fluids, 7 m (23 ft) in bulk materials~~
  - ~~FMU44: 20 m (66 ft) in fluids, 10 m (33 ft) in bulk materials~~

#### Features and benefits

- Quick and simple commissioning via menu-guided on-site operation with four-line, multilingual plain text display
- Envelope curves on the on-site display for simple diagnosis
- Easy remote operation, diagnosis and measuring point documentation with the free operating program FieldCare supplied.
- Suitable for explosion hazardous areas (Gas-Ex, Dust-Ex)
- Linearization function (up to 32 points) for conversion of the measured value into any unit of length, volume or flow rate
- Non-contact measurement method minimizes service requirements
- ~~Optional remote display and operation (up to 20 m (66 ft) from transmitter)~~
- Installation ~~possible from thread G 1½" or 1½" NPT upwards~~
- Integrated temperature sensor for automatic correction of the temperature dependent sound velocity

## Input

**Measured variable**

The distance D between the sensor membrane and the product surface is measured.

Using the linearization function, the device uses D to calculate:

- level L in any units
- volume V in any units
- Flow Q across measuring weirs or open channels in any units

**Measuring range**

The measuring range is limited by the range of a sensor. The sensor range is, in turn, dependent on the operating conditions. To estimate the actual range, proceed as follows (see also the calculation example in the diagram):

1. Determine which of the influences shown in the following table are appropriate for your process.
2. Add the corresponding attenuation values.
3. From the total attenuation, use the diagram to calculate the range.

Fluid surface	Attenuation
Calm	0 dB
Waves	5 to 10 dB
Strong turbulence (e.g. stirrers)	10 to 20 dB
Foaming	Please contact your Endress+Hauser sales representative.

Bulk material surface	Attenuation
Hard, rough (e.g. rubble)	40 dB
Soft (e.g. peat, dust-covered clinker)	40 to 60 dB

Dust	Attenuation
No dust formation	0 dB
Little dust formation	5 dB
Heavy dust formation	5 to 20 dB

Filling curtain in detection range	Attenuation
None	0 dB
Small quantities	5 to 10 dB
Large quantities	10 to 40 dB

Temperature difference between sensor and product surface	Attenuation
to 20 °C (68 °F)	0 dB
to 40 °C (104 °F)	5 to 10 dB
to 80 °C (176 °F)	10 to 20 dB

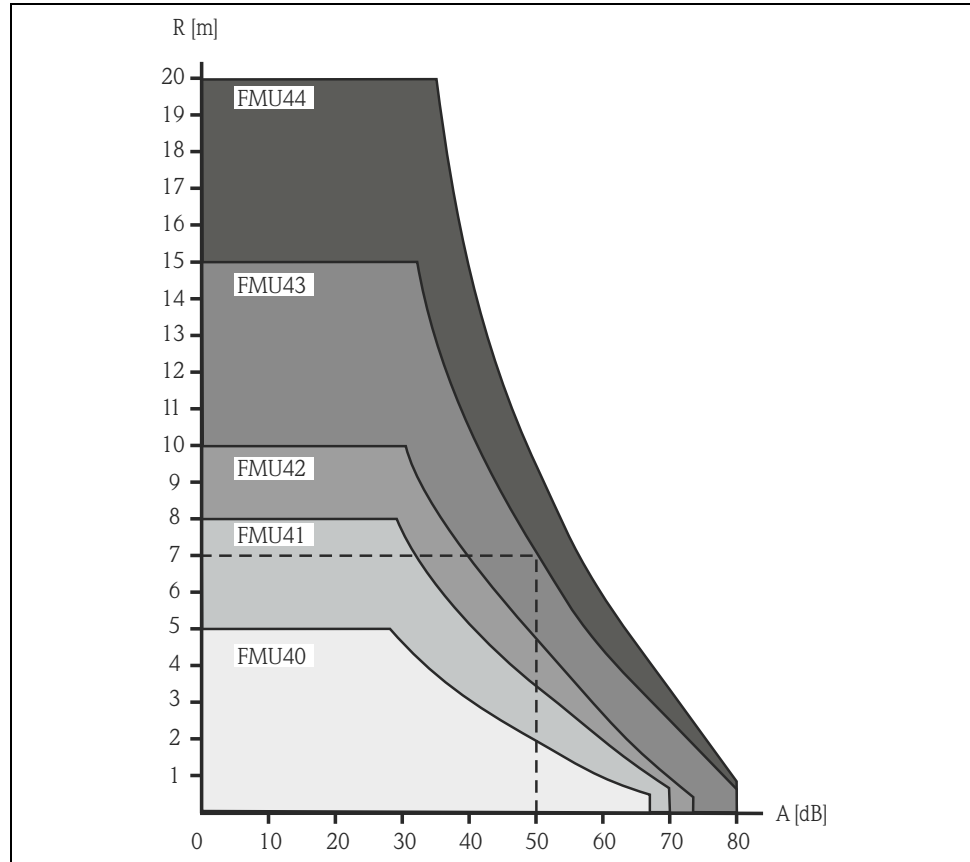

A0019268

A Attenuation (dB)  
R Range (m)

**Example (for FMU43)**

For typical solid applications, a certain amount of dust coverage is normally present. Therefore, the following range results from the table and the diagram:

- Dust-covered rubble approx. 50 dB
  - No dust formation 0 dB
  - No filling curtain in detection range 0 dB
  - Temperature diff. < 20°C 0 dB
- approx. 50 dB      ⇒ range approx. 7 m (23 ft)

These measuring conditions have been taken into account during the calculation of the maximum measuring range in solid applications.

**Operating frequency**

Sensor	Operating frequency
FMU40	approx. 70 kHz
FMU41	approx. 50 kHz
FMU42	approx. 42 kHz
FMU43	approx. 35 kHz
FMU44	approx. 30 kHz

## Output

---

<b>Output signal</b>	According to the instrument version ordered: <ul style="list-style-type: none"><li>■ 4...20 mA with HART protocol</li><li>■ <del>PROFIBUS PA</del></li><li>■ <del>FOUNDATION Fieldbus</del></li></ul>
<b>Signal on alarm</b>	Error information can be accessed via the following interfaces: <ul style="list-style-type: none"><li>■ On-site display (error symbol, error code and plain text description)</li><li>■ Current output, signal on error can be selected (e.g. according to NAMUR recommendation NE43)</li><li>■ Digital interface</li></ul>
<b>Load HART</b>	Minimum load for HART communication: 250 $\Omega$
<b>Output damping</b>	Freely selectable, 0 to 255 s
<b>Linearization</b>	<p>The linearization function of the Prosonic M allows conversion of the measured value into any unit of length or volume. In open channels or measuring weirs, also a flow linearization is possible (calculation of the flow from the measured level). The linearization table for calculating the volume in an horizontal cylindrical tank is preprogrammed. You can also enter any number of other tables containing up to 32 value pairs either manually or semi-automatically (by filling the vessel under controlled conditions). The supplied FieldCare operating program can automatically calculate the table for any tank, weir or flume and upload it into the device.</p> <p>Flow curves for open channels can be calculated and entered into the instrument by the FieldCare as well (→ <a href="#">29</a>, "Operation with FieldCare").</p>

---

## Power supply

### Terminal compartment

In the F12 housing, the terminals are located underneath the housing cover. ~~In the T12 housing, they are under the cover of the separate terminal compartment.~~

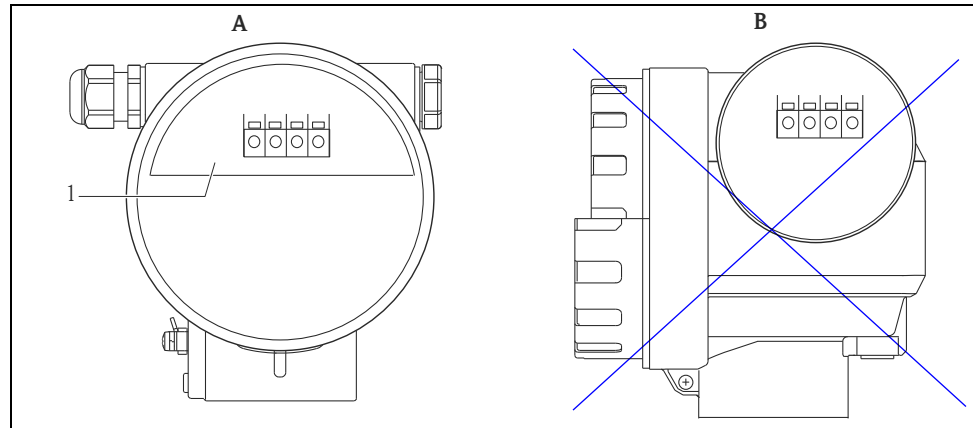

A F12 housing  
B T12 housing  
1 Sealed terminal compartment

### Terminal assignment

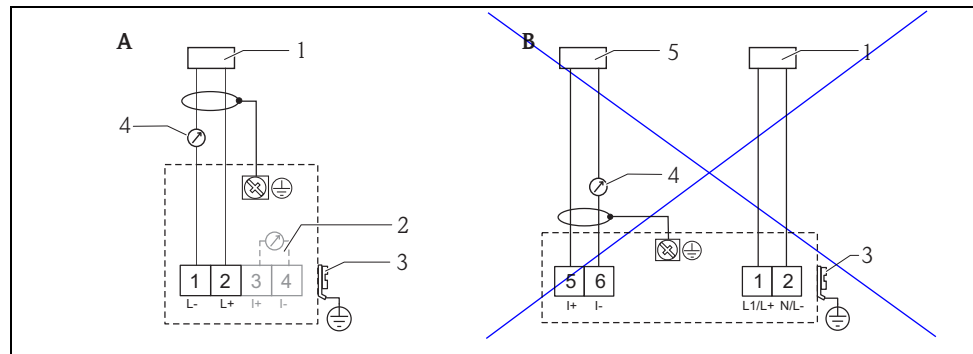

A Loop-powered version  
B 4-wire version (active)  
1 Power  
2 Test clamp for testing of the signal current  
3 Plant ground  
4 4-20 mA HART  
5 Display unit, recorder, PCS

- Connect the connecting line to the screw terminals (line cross-sections of 0.5 to 2.5 mm<sup>2</sup> (20 to 14 AWG)) in the terminal compartment.
- Use 2-wire twisted pair cable with screen for the connection.
- Protective circuitry against reverse polarity, RFI and over-voltage peaks is built into the device (see also Technical Information TI00241F/00/EN "EMC Test Procedures") → 21, "Electromagnetic compatibility (EMC)".
- A standard installation cable is sufficient if only the analogue signal is used. Use a screened cable when working with a superimposed communication signal (HART).

**THIS PAGE ONLY  
NO EXCEPTION TAKEN**

Version		Current consumption	Terminal voltage minimum	Terminal voltage maximum
2-wire HART	Standard	4 mA	14 V	36 V
		20 mA	8 V	36 V
	Ex ia	4 mA	14 V	30 V
		20 mA	8 V	30 V
	Ex d	4 mA	14 V	30 V
		20 mA	11 V	30 V
Fixed current, adjustable, e.g. for solar power operation (measured value via HART)	Standard	11 mA	10 V	36 V
	Ex ia	11 mA	10 V	30 V
Fixed current for HART multidrop mode	Standard	4 mA <sup>1)</sup>	14 V	36 V
	Ex ia	4 mA <sup>1)</sup>	14 V	30 V

1) Start-up current 11 mA

#### HART, 4-wire, active

Version	Voltage	Max. load
DC	10.5 to 32 V	600 Ω
AC 50/60 Hz	90 to 253 V	600 Ω

**Terminals** Cable cross-section: 0.5 to 2.5 mm<sup>2</sup> (20 to 14 AWG)

**Cable entry**

- Cable gland: M20x1.5 (recommended cable diameter 6 to 10 mm (0.24 to 0.39 in))
- Cable entry G-1/2" or NPT 1/2"
- PROFIBUS PA M12 plug
- FOUNDATION Fieldbus 7/8" plug

Version	Power consumption
2-wire	51 mW to 800 mW
4-wire AC	max. 4VA
4-wire DC; FMU40/41	330 mW to 830 mW
4-wire DC; FMU42/43	600 mW to 1 W

Communication	Current consumption
HART	3.6 to 22 mA
PROFIBUS PA	max. 13 mA
FOUNDATION Fieldbus	max. 15 mA

**HART ripple** 47 to 125 Hz: V<sub>pp</sub> = 200 mV (measured at 500 Ω)

**Max. noise HART** 500 Hz to 10 kHz: V<sub>rms</sub> = 2.2 mV (measured at 500 Ω)

**Galvanic isolation** With 4-wire devices, the evaluation electronics and mains voltage are galvanically isolated from each other.

## Performance characteristics

**Reaction time** The reaction time depends on the parameter settings. The minimum values are:

- 2-wire devices (FMU40/41/42): min. 2 s
- ~~2-wire devices (FMU43 - PROFIBUS PA or FOUNDATION Fieldbus): min. 2 s~~
- ~~2-wire devices (FMU44): min. 3 s~~
- ~~4-wire devices (FMU40/41/42/43/44): 0.5 s~~

**Reference operating conditions**

- Temperature = +20 °C (+68 °F)
- Pressure = 1013 mbar abs. (15 psi abs.)
- Humidity = 50 %
- Ideal reflective surface (e.g. calm, smooth fluid surface)
- No interference reflections within signal beam
- Set application parameters:
  - Tank shape = dome ceiling
  - Medium property = liquid
  - Process conditions = standard liquid

**Measured value resolution**

Sensor	Measured value resolution
FMU40	1 mm (0.04 in)
<del>FMU41</del>	<del>1 mm (0.04 in)</del>
<del>FMU42</del>	<del>2 mm (0.08 in)</del>
<del>FMU43</del>	<del>2 mm (0.08 in)</del>
<del>FMU44</del>	<del>2 mm (0.08 in)</del>

**Pulse frequency**

- 2-wire devices (FMU40/41/42): max. 0.5 Hz
- ~~2-wire devices (FMU43 - PROFIBUS PA or FOUNDATION Fieldbus): max. 0.5 Hz~~
- ~~2-wire devices (FMU44): max. 0.3 Hz~~
- ~~4-wire devices (FMU40/41/42/43/44): max. 2 Hz~~

The exact values are dependent on the type of device and the parameter settings.

**Maximum measuring error<sup>1)</sup>** ±0.2 % of the maximum span of the sensor

2)

**Typical measuring error<sup>2)</sup>**

Include linearity, repeatability and hysteresis  
Better than:

Sensor	Measuring error
FMU40	±2 mm (0.08 in) or 0.2 % of measuring distance*
<del>FMU41</del>	<del>±2 mm (0.08 in) or 0.2 % of measuring distance*</del>
<del>FMU42</del>	<del>±4 mm (0.16 in) or 0.2 % of measuring distance*</del>
<del>FMU43</del>	<del>±4 mm (0.16 in) or 0.2 % of measuring distance*</del>
<del>FMU44</del>	<del>±4 mm (0.16 in) or 0.2 % of measuring distance*</del>

\* whichever is greater

1) according to EN 61298-2

2) with reference operating conditions

**Influence of the vapor pressure**

The vapor pressure at 20 °C (68 °F) gives a hint on the accuracy of the ultrasonic level measurement. If the vapor pressure at 20 °C (68 °F) is below 50 mbar (1 psi), ultrasonic level measurement is possible with a very high accuracy. This is valid for water, aqueous solutions, water-solid-solutions, dilute acids (hydrochloric acid, sulfuric acid, ...), dilute bases (caustic soda, ...), oils, greases, slurries, pastes, ... High vapor pressures or outgassing media (ethanol, acetone, ammonia, ...) can influence the accuracy. If conditions like these are present, please contact your Endress+Hauser sales representative.

**Installation**

**Installation variants FMU40, FMU41**

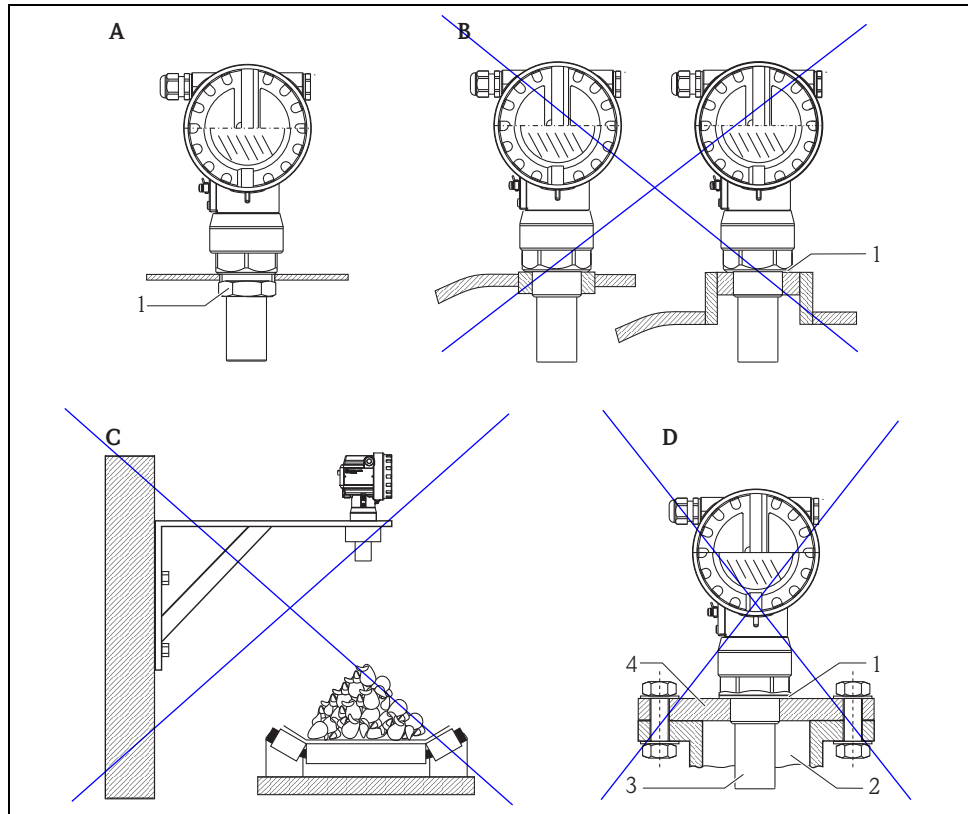

- A Installation with counter nut
  - 1 Counter nut (PC) supplied for G 1½" and G 2" instruments
- ~~B Installation with sleeve
 
  - 1 Sealing (EPDM)-supplied~~
- ~~C Installation with installation bracket~~
- ~~D Installation with screw in flange
 
  - 1 Sealing (EPDM)-supplied
  - 2 Nozzle
  - 3 Sensor
  - 4 Screw in flange~~

For installation bracket or adapter flange → 43, "Accessories".

- Avoid measurements through the filling curtain (4).
- Make sure that equipment (5) such as limit switches, temperature sensors, etc. are not located within the emitting angle  $\alpha$ . In particular, symmetrical equipment (6) such as heating coils, baffles etc. can influence measurement.
- Align the sensor so that it is vertical to the product surface (7).
- Never install two ultrasonic measuring devices in a tank, as the two signals may affect each other.
- To estimate the detection range, use the 3 dB emitting angle  $\alpha$ .

Sensor	$\alpha$	$L_{\max}$	$r_{\max}$
FMU40	11°	5 (16)	0.48 (1.6)
FMU41	11°	8 (26)	0.77 (2.5)
FMU42	9°	10 (33)	0.79 (2.6)
FMU43	6°	15 (49)	0.79 (2.6)
FMU44	11°	20 (66)	1.93 (6.3)

m (ft)

#### Installation in narrow shafts

In narrow shafts with strong interference echoes, we recommend using an ultrasound guide pipe (e.g. PE or PVC wastewater pipe) with a minimum diameter of 100 mm (3.94 in). Make sure that the pipe is not soiled by accumulated dirt. If necessary, clean the pipe at regular intervals.

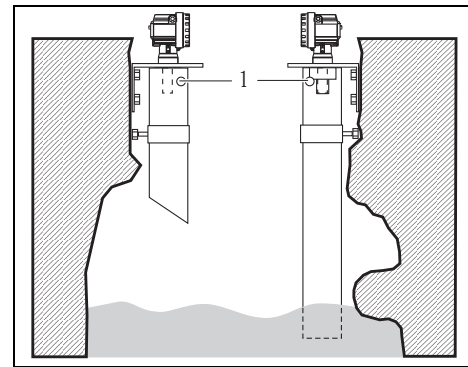

1 Venting hole

A0019310

#### Installation conditions for flow measurements

- Install the Prosonic M at the inflow side, as close above the maximum water level  $H_{\max}$  as possible (take into account the blocking distance BD).
- Position the Prosonic M in the middle of the channel or weir.
- Align the sensor membrane parallel to the water surface.
- Keep to the installation distance of the channel or weir.
- You can enter the "Flow to Level" linearization curve ("Q/h curve") using FieldCare or manually via the on-site display.

**THIS PAGE ONLY  
NO EXCEPTION TAKEN**

**Blocking distance,  
nozzle installation**

Install the Prosonic M at a height so that the blocking distance BD is not undershot, even at maximum fill level. Use a pipe nozzle if you cannot maintain the blocking distance in any other way. The interior of the nozzle must be smooth and may not contain any edges or welded joints. In particular, there should be no burr on the inside of the tank-side nozzle end. Note the specified limits for nozzle diameter and length. To minimise disturbing factors, we recommend an angled socket edge (ideally 45°).

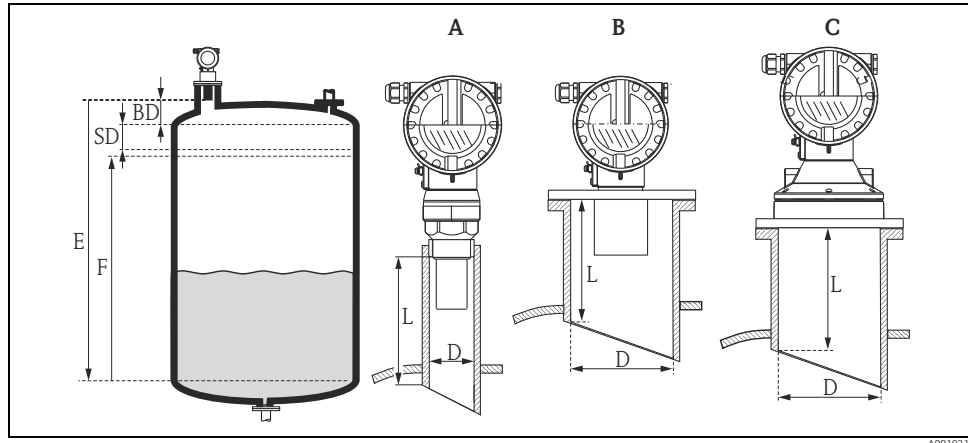

A FMU40, FMU41  
B FMU42, FMU44  
C FMU43

BD Blocking distance  
SD Safety distance  
E Empty calibration

F Full calibration (span)  
D Nozzle diameter  
L Nozzle length

Nozzle diameter	Maximum nozzle length [mm (in)]				
	FMU40	FMU41	FMU42	FMU43	FMU44
DN50/2"	80 (3.15)	-	-	-	-
DN80/3"	240 (9.45)	240 (9.45)	250 (9.84)		
DN100/4"	300 (11.8)	300 (11.8)	300 (11.8)	300 (11.8)	
DN150/6"	400 (15.7)	400 (15.7)	400 (15.7)	300 (11.8)	400 (15.7)
DN200/8"	400 (15.7)	400 (15.7)	400 (15.7)	300 (11.8)	400 (15.7)
DN250/10"	400 (15.7)	400 (15.7)	400 (15.7)	300 (11.8)	400 (15.7)
DN300/12"	400 (15.7)	400 (15.7)	400 (15.7)	300 (11.8)	400 (15.7)
<b>Sensor characteristics</b>					
Emitting angle $\alpha$	11°	11°	9°	6°	11°
Blocking distance [m (ft)]	0.25 (0.8)	0.35 (1.1)	0.4 (1.3)	0.6 (2.0)	0.5 (1.6)
Max. range [m (ft)] in liquids	5 (16.0)	8 (26.0)	10 (33.0)	15 (49.0)	20 (66.0)
Max. range [m (ft)] in solids	2 (6.6)	3.5 (11.0)	5 (16.0)	7 (23.0)	10 (33.0)

**Caution!**

If the blocking distance is undershot, it may cause device malfunction.

**Note!**

In order to notice if the level approaches the blocking distance, you can specify a safety distance (SD). If the level is within this safety distance, the Prosonic M outputs a warning or alarm message.

## Environment

<b>Ambient temperature</b>	<p>–40 °C to +80 °C (–40 °F to +176 °F)          The functionality of the LC display becomes restricted at <math>T_u &lt; -20\text{ °C}</math> (<math>T_u &lt; -4\text{ °F}</math>) and <math>T_u &gt; +60\text{ °C}</math> (<math>T_u &gt; 140\text{ °F}</math>).          If the device is operated outdoors in strong sunlight, you should use a protective cover (→ 43).</p>
<b>Storage temperature</b>	–40 °C to +80 °C (–40 °F to +176 °F)
<b>Resistance to alternating temperature cycles</b>	To DIN EN 60068-2-14; Nb test: +80°C/–40°C (+176 °F/–40 °F), 1K/min, 100cycles
<b>Climate class</b>	DIN EN 60068-2-38 (Test Z/AD) DIN/IEC 68 T2-30Db
<b>Ingress protection</b>	<ul style="list-style-type: none"> <li>■ With closed housing, tested according to             <ul style="list-style-type: none"> <li>– IP68, NEMA 6P (24h at 1.83 m (6 ft) under water surface)</li> <li>– IP66, NEMA 4x</li> </ul> </li> <li>■ With open housing: IP20, NEMA 1 (also ingress protection of the display)</li> </ul> <p>Caution!          Degree of protection IP68 NEMA 6P applies for M12 PROFIBUS-PA plugs and for 7/8" FF plug only when the cable is plugged in.</p>
<b>Vibration resistance</b>	DIN EN 60068-2-64 / IEC 68-2-64: 20...2000 Hz, 1 (m/s <sup>2</sup> ) <sup>2</sup> /Hz; 3 x 100 min
<b>Electromagnetic compatibility (EMC)</b>	<ul style="list-style-type: none"> <li>■ Electromagnetic compatibility according to all relevant requirements of the EN 61326- series and NAMUR recommendation EMC (NE21). For details see declaration of conformity.</li> <li>■ A standard installation cable is sufficient if only the analogue signal is used. Use a screened cable when working with a superimposed communication signal (HART).</li> </ul>

## Process

<b>Process temperature</b>	<p>–40°C to +80°C (–40 °F...+176 °F)          A temperature sensor is integrated in the sensor for correction of the temperature-dependent time-of-flight.</p>
<b>Process pressure</b>	<ul style="list-style-type: none"> <li>■ FMU40/41: 0.7 bar to 3 bar abs. (10.15 psi...43.5 psi abs.)</li> <li>■ <del>FMU42/43/44: 0.7 bar to 2.5 bar abs. (10.15 psi...36.25 psi abs.)</del></li> </ul>

## Mechanical construction

Design; dimensions

FMU40, FMU41

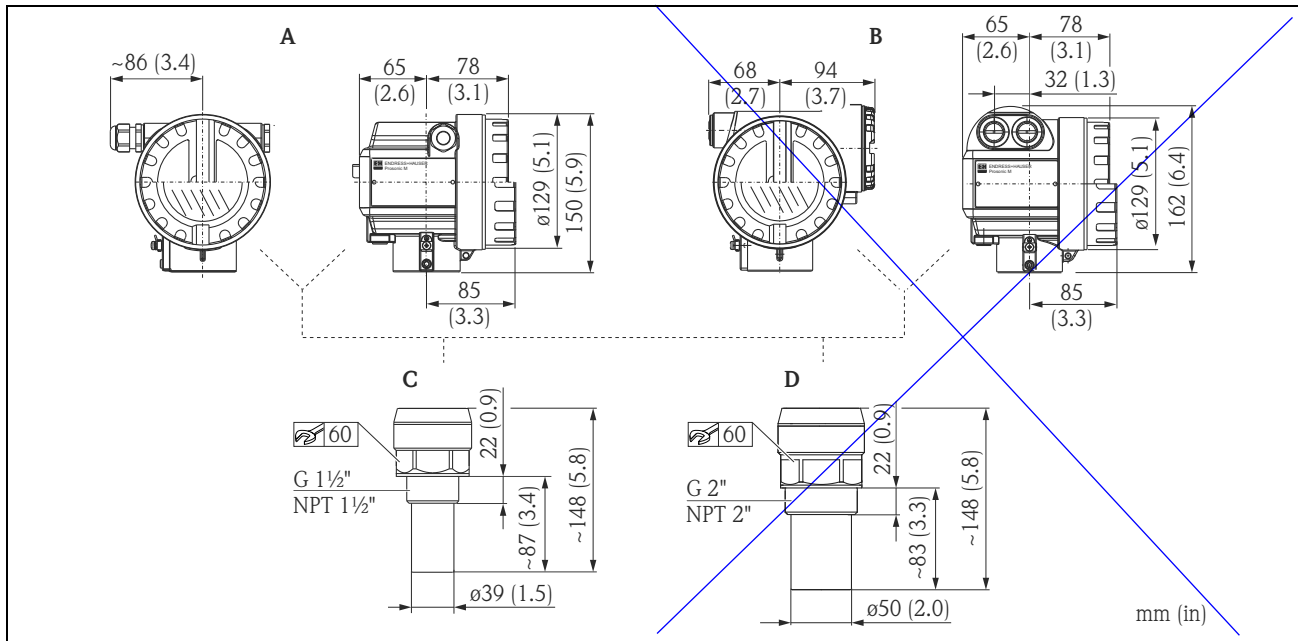

A F12 housing  
C FMU40

B T12 housing  
D FMU41

FMU42, FMU44 with slip-on flange

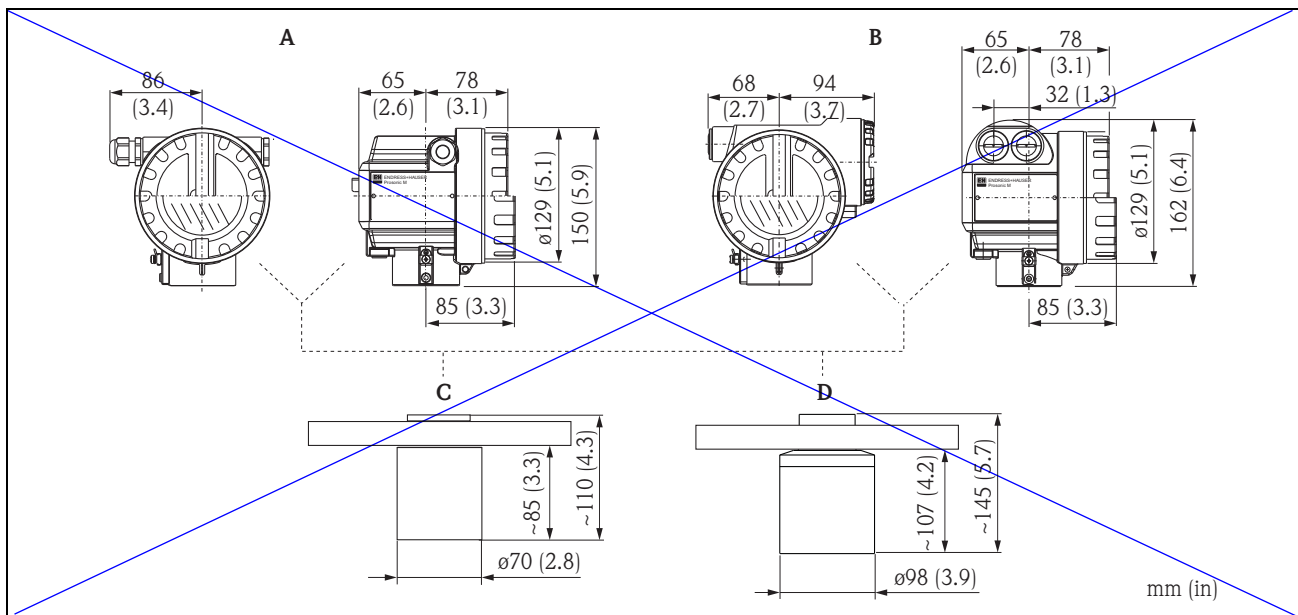

A F12 housing  
C FMU42

B T12 housing  
D FMU44

Flanges for FMU42 and FMU44

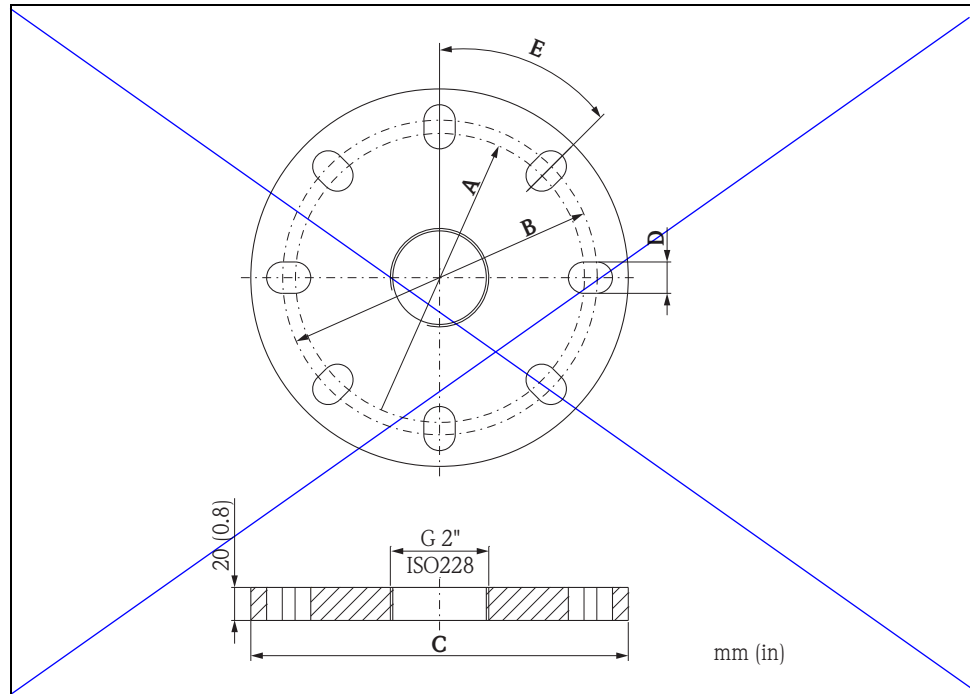

A0019343

suitable for	A	B	C	D	E	number of boreholes
3" 150 lbs / DN80 PN16 / 10K 80	150 mm (5.91")	160 mm (6.30")	200 mm (7.87")	19 mm (0.75")	45°	8
4" 150 lbs / DN100 PN16 / 10K 100	175 mm (6.90")	190.5 mm (7.50")	228.6 mm (9.00")	19 mm (0.75")	45°	8
6" 150 lbs / DN150 PN16 / 10 K 150	240 mm (9.45")	241.3 mm (9.50")	285 mm (11.22")	23 mm (0.91")	45°	8
8" 150 lbs	298.5 mm (11.75")	298.5 mm (11.75")	342.9 mm (13.50")	22.5 mm (0.89")	45°	8
DN200 PN16 / 10 K 200	290 mm (11.42")	295 mm (11.61")	340 mm (13.39")	23 mm (0.91")	30°	12

Weight

Sensor	Weight kg (lbs)
FMU40	approx. 2.5 (5.51)
FMU41	approx. 2.6 (5.73)
FMU42	approx. 3 (6.62)
FMU43	approx. 3.5 (7.72)
FMU44	approx. 4 (8.82)

**Housing design****Types of housings**

- F12 housing with sealed terminal compartment for standard or Ex ia applications
- ~~T12 housing with separate terminal compartment and explosionproof encapsulation~~

**Material**

Aluminium, powder-coated (→ 26)

**Cover**

- Aluminium, for version without on-site display
- Inspection glass for version with on-site display. This version cannot be supplied together with the ATEX II 1/2 D certificate.

**Process connection**

Sensor	Process connection
FMU40	<ul style="list-style-type: none"> <li>■ <del>Thread G 1½"</del></li> <li>■ Thread NPT 1½" - 11.5</li> </ul>
FMU41	<ul style="list-style-type: none"> <li>■ <del>Thread 2"</del></li> <li>■ <del>Thread NPT 2" - 11.5</del></li> </ul>
FMU42	<ul style="list-style-type: none"> <li>■ <del>Universal flange DN 80 PN16 / ANSI 3" 150 lbs / JIS 10K 80</del></li> <li>■ <del>Universal flange DN 100 PN16 / ANSI 4" 150 lbs / JIS 10K 100</del></li> <li>■ <del>Mounting bracket</del></li> </ul>
FMU43	<ul style="list-style-type: none"> <li>■ <del>Universal flange DN 100 / ANSI 4" / JIS16K100</del></li> <li>■ <del>Mounting bracket</del></li> </ul>
FMU44	<ul style="list-style-type: none"> <li>■ <del>Universal flange DN 100 PN16 / ANSI 4" 150 lbs / JIS 10K 100</del></li> <li>■ <del>Universal flange DN 150 PN16 / ANSI 6" 150 lbs / JIS 10K 150</del></li> <li>■ <del>Universal flange DN200 PN16 / JIS 10K 200</del></li> <li>■ <del>Flange ANSI 8" 150 lbs</del></li> <li>■ <del>Mounting bracket</del></li> </ul>

Material  
(not in contact with process)

T12 and F12 housing (powder-coated)

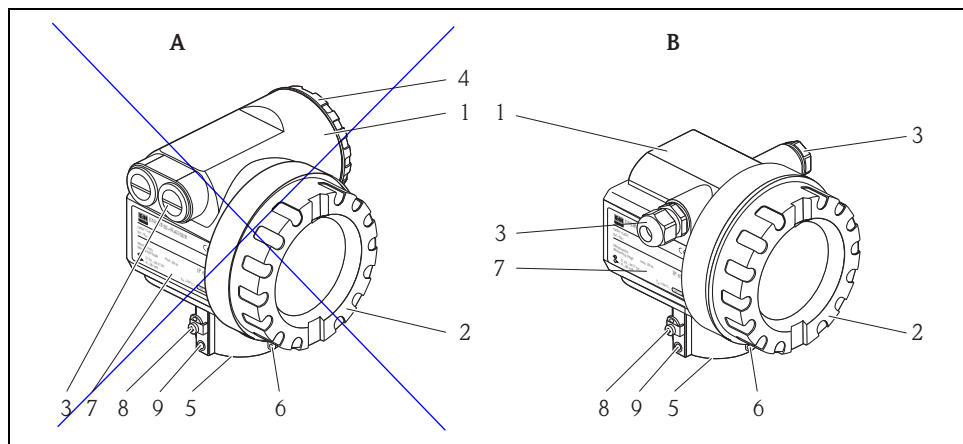

A ~~T12 housing~~  
B F12 housing

Pos.	Part	Material
1	T12 and F12 housing	AlSi10Mg
2	Cover (Display)	AlSi10Mg
	O-ring	EPDM
	Window	ESG-K-Glass
	Sealing of the glass	Silicone sealing compound Gomastit 402
3	Cable gland	Polyamid (PA), CuZn nickel-plated
	O-Ring	EPDM
	Plug	PBT-GF30 or 1.0718 galvanized PE or 3.1655
	Adapter	316L (1.4435) or AlMgSiPb (anodized)
4	Cover (Connection compartment)	AlSi10Mg
	O-ring	EPDM
	Clamp	Screw: A4; Clamp: CuZn nickel-plated; Spring washer: A4
5	O-ring	EPDM
6	Tag	304 (1.4301)
	Rope	VA
	Crimp sleeve	Aluminium
7	Nameplate	316L (1.4404)
	Groove pin	A4 (1.4571)
8	Ground terminal	Screw: A2; Springwasher: A4; Clamp: 304 (1.4301) Holder: 301 (1.4310)
9	Screw	A2-70

Note!  
~~Seawater-resistant parts please order on request (complete in 316L (1.4404)).~~

**Material**  
**(in contact with process)**

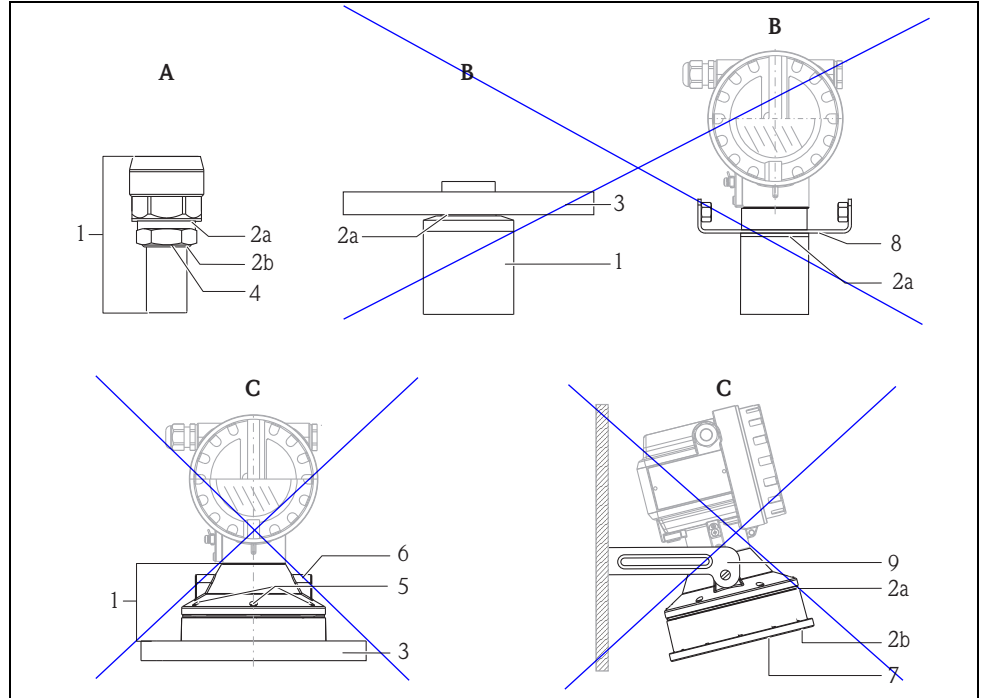

A0019054

Pos.	Part	A FMU40, FMU41	B FMU42, FMU44	C FMU43
1	Sensor	PVDF	<del>PVDF</del>	UP (Unsaturated polyester resin)
2a	Sealing	EPDM	<del>EPDM or FKM</del>	EPDM
2b	O-ring	EPDM	<del>—————</del>	EPDM
3	Flange	-	<del>PP, PVDF or stainless steel 316L (1.4435 or 1.4404) 1)</del>	<del>PP or 316 Ti (1.4571)</del>
4	Counter nut	PC	-	-
5	Screws	-	-	<del>V2A</del>
6	Thread insert for mounting bracket	-	-	<del>CuZn</del>
7	Sensor membrane	-	-	<del>316 Ti (1.4571)</del>
8	Mounting bracket (retainer) Screws	- -	<del>316 Ti (1.4571) V4A</del>	- -
9	Mounting bracket Screws	- -	<del>316 Ti (1.4571) V2A</del>	<del>316 Ti (1.4571) V2A</del>

1) ~~Endress+Hauser supplies DIN/EN flanges made of stainless steel AISI 316L with the material number 1.4404 or 1.4435. With regard to their temperature stability properties, the materials 1.4404 and 1.4435 are grouped under 13E0 in EN 1092-1 Tab. 18. The chemical composition of the two materials can be identical.~~

**Note!**

The chemical compatibility of the sensors must be checked before installation with compatibility charts.

## Ordering information

Product structure FMU40

Versions that mutually exclude one another are not marked.

010	<b>Certificates</b>
	<p><b>A</b> Variant for non-hazardous area</p> <p><del>E</del> NEPSI Ex nA IIC T6 Gc</p> <p>G ATEX II 3G Ex nA IIC T6 Gc</p> <p>I NEPSI Ex ia IIC T6</p> <p>J NEPSI Ex d(ia) IIC T6</p> <p>K INMETRO Ex ia IIC T6 Ga/Gb</p> <p>L INMETRO Ex d [ia] IIC T6 Ga/Gb</p> <p>N CSA General Purpose</p> <p>Q NEPSI DIP</p> <p>S FM IS Cl. I,II,III Div. 1 Gr. A-G / NI Cl. I Div. 2</p> <p>T FM XP Cl. I,II,III Div. 1 Gr. A-G</p> <p>U CSA IS Cl. I,II,III Div. 1 Gr. A-G / NI Cl. I Div. 2</p> <p>V CSA XP Cl. I,II,III Div. 1 Gr. A-G</p> <p>1 ATEX II 1/2G Ex ia IIC T6 Ga/Gb</p> <p>2 ATEX II 1/2D, Alu blind cover</p> <p>4 ATEX II 1/2G Ex d (ia) IIC T6 Ga/Gb</p> <p>5 ATEX II 1/3D</p> <p>6 ATEX II 3D Ex ta IIIC T* °C Dc</p> <p>Y Special certificate</p>
020	<b>Process connection</b>
	<p><del>R</del> G 1½" thread ISO 228</p> <p><b>N</b> NPT 1½" - 11,5 thread</p> <p><del>Y</del> Special version</p>
030	<b>Power supply/communication</b>
	<p><b>B</b> 2 wire, 4...20mA-loop/HART</p> <p><del>H</del> 4 wire, 10,5...32 VDC / 4-20mA HART</p> <p>G 4 wire, 90...253 VAC / 4-20mA HART</p> <p>D 2 wire, PROFIBUS PA</p> <p>F 2 wire, FOUNDATION Fieldbus</p> <p>J 2-wire, 4-20mA HART, 5-point linearity protocol</p> <p>K 2-wire, PROFIBUS PA, 5-point linearity protocol</p> <p>L 2-wire, FOUNDATION Fieldbus, 5-point linearity protocol</p> <p>M 4-wire, 90-253VAC; 4-20mA HART, 5-point linearity protocol</p> <p>N 4-wire, 10.5-32VDC;4-20mA HART, 5-point linearity protocol</p> <p>P 2-wire, 4-20mA HART, 3-point linearity protocol</p> <p>Q 2-wire, PROFIBUS PA, 3-point linearity protocol</p> <p>R 2-wire, FOUNDATION Fieldbus, 3-point linearity protocol</p> <p>S 4-wire, 90-253 VAC, 4-20mA HART, 3-point linearity protocol</p> <p>T 4-wire, 10.5-32 VDC, 4-20mA HART, 3-point linearity protocol</p> <p>Y Special version</p>
040	<b>Display / on-site operation</b>
	<p><del>1</del> Without LC display</p> <p><b>2</b> With LC display VU331 incl. on-site operation</p> <p><del>3</del> Prepared for remote display FHX 40</p> <p>9 Special version</p>
050	<b>Housing</b>
	<p><b>A</b> Aluminium F12 housing coated to IP68 NEMA6P</p> <p><del>C</del> Aluminium T12 housing coated to IP68 NEMA6P; with separate terminal compartment</p> <p>D Aluminium T12 housing coated to IP68 NEMA6P+OVP; with separate terminal compartment; with overvoltage protection</p> <p>9 Special version</p>

**THIS PAGE ONLY  
NO EXCEPTION TAKEN**

050								Housing
060								Screw union/entry
								2 M20x1.5 screw union
								<del>3 G 1/2" entry</del>
								4 NPT 1/2" entry
								<del>5 M12 PROFIBUS-PA plug-in connector</del>
								6 7/8" FF plug
								9 Special version
995								Marking
								<del>1 Tagging (TAG)</del>
								<del>2 Bus address</del>
FMU40 -	A	N	B	2	A	4		Product designation

**THIS PAGE ONLY  
NO EXCEPTION TAKEN**

**5-point linearity protocol**

The following must be taken into account if option "5 point linearity protocol" has been selected:

- The five points of the linearity protocol are evenly distributed across the measuring range (0 % to 100 %). In order to define the measuring range, Empty calibration (E) and Full calibration (F) have to be specified.<sup>3)</sup>
- The following restrictions have to be taken into account when defining E and F:

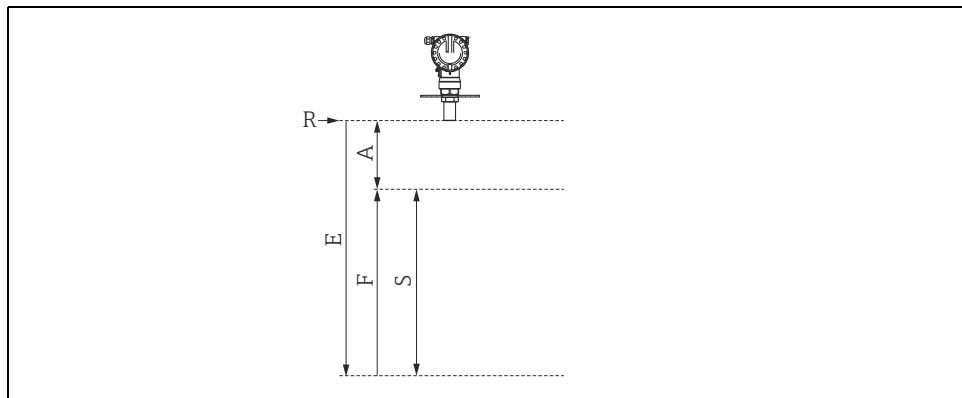

A0019522

Pos.	Measuring range	FMU40	<del>FMU41</del>	<del>FMU42</del>	<del>FMU43</del>	<del>FMU44</del>
E	Maximum value for the empty calibration	5000 (197)	<del>8000 (315)</del>	<del>10000 (394)</del>	<del>15000 (591)</del>	<del>20000 (787)</del>
F	Maximum value for the full calibration	4750 (187)	<del>7500 (295)</del>	<del>9600 (378)</del>	<del>14400 (567)</del>	<del>19500 (768)</del>
S	Minimum span E-A	100 (3.94)	<del>100 (3.94)</del>	<del>100 (3.94)</del>	<del>150 (591)</del>	<del>250 (9.84)</del>
A	Minimum distance between reference point R from sensor and 100 % level	250 (9.84)	<del>500 (19.7)</del>	<del>400 (15.7)</del>	<del>600 (23.6)</del>	<del>500 (19.7)</del>

Dimensions mm (in)

Note!  
The linearity is checked under reference conditions.

**Scope of delivery**

- Instrument according to the version ordered
- Endress+Hauser operating program on the enclosed CD-ROM
- Brief operating instructions according to the communication version
- For certified instrument versions: Safety Instructions, Control- or Installation drawings
- ~~For FMU40 \*R\*\*\*\* and FMU41 \*R\*\*\*\*: counter nut (PC)~~
- For FMU40/41: sealing ring (EPDM)
- ~~For gland M20x1.5:  
— 1 cable gland for 2-wire instruments  
— 2 cable glands for 4-wire instruments  
The cable glands are mounted on delivery.~~

3) If the values for the full calibration and empty calibration are missing or outside the specified area, the devices are tested with the maximum value according to the table.

**Commubox FXA195 HART**

For intrinsically safe communication with FieldCare via the USB interface.  
For details refer to TI00404F/00/EN.

**Commubox FXA291**

The Commubox FXA291 connects Endress+Hauser field instruments via the service interface to the USB interface of a personal computer or a notebook. For details refer to TI00405C/07/EN.

Note!

For the instrument you need the "ToF Adapter FXA291" as an additional accessory.

**ToF Adapter FXA291**

The ToF Adapter FXA291 connects the Commubox FXA291 via the USB interface of a personal computer or a notebook to the instrument. For details refer to KA00271F/00/A2.

**Remote display FHX40**

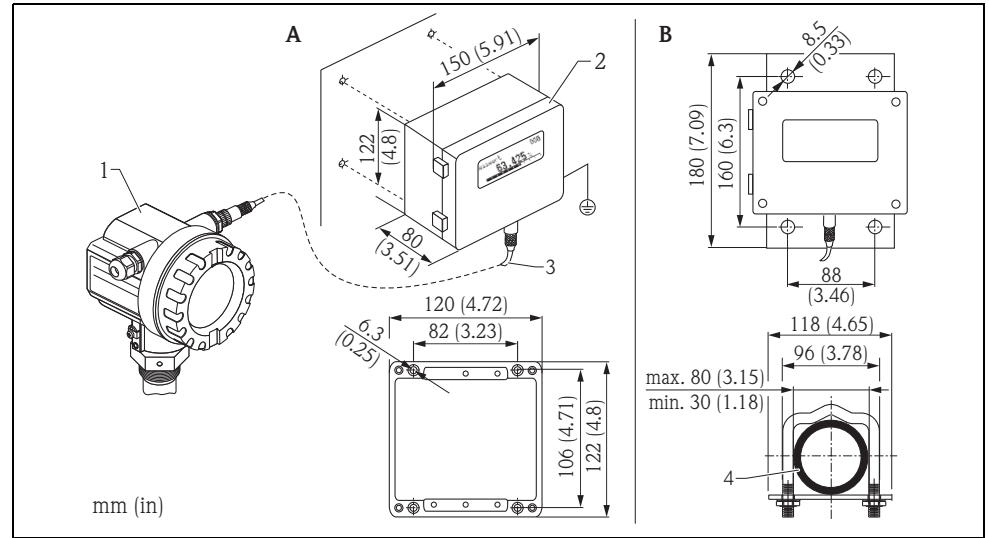

- A Wall mounting (without mounting bracket)
- B Pipe mounting (mounting bracket and plate supplied optionally, see product structure)
- 1 Prosonic M, Levelflex M, Micropilot M
- 2 Separate housing FHX40 (IP65)
- 3 Cable
- 4 Pipe

For the device families Micropilot FMR2xx, Levelflex FMP4x and Prosonic FMU4x, the remote display FHX40 must be only used for the HART communication version. For more details, see KA00202F/00/C4. Weitere Details, siehe KA00202F/00/C4.

For Fieldbus Foundation and Profibus PA devices the usage of RID14, RID16 is recommended. Further details are attached below → 50.

**Order information FHX40**

<b>010</b>	<b>Approval:</b>
	A Non-hazardous area 2 ATEX II 2G Ex ia IIC T6 3 ATEX II 2D Ex ia IIIC T80°C G IECEx Zone1 Ex ia IIC T6/T5 S FM IS Cl. I Div.1 Gr. A-D, zone 0 U CSA IS Cl. I Div.1 Gr. A-D, zone 0 N CSA General Purpose K TIIS Ex ia IIC T6 C NEPSI Ex ia IIC T6/T5 Y Special version, TSP-Nr. to be spec.
<b>020</b>	<b>Cable:</b>
	1 20 m/65 ft: for HART 5 20 m/65 ft: for PROFIBUS PA, FOUNDATION Fieldbus 9 Special version, TSP-Nr. to be spec.
<b>030</b>	<b>Additional option:</b>
	A Basic version B Mounting bracket, pipe 1" 2"

## CATALOG & BULLETIN INFORMATION

### STATIC MIXER

Function: Mix chemical feeds in common raw water line prior to flow division to individual filters

Description: 14" Schedule 10S (0.188" Wall) 316L Stainless Steel Hybrid Static Mixer, Three (3) Fixed 316L Stainless Steel Mixing Elements, AWWA/NSF 61 Approved Epoxy Coated Carbon Steel 150 Lb. Flat Face Slip-On Flanged Ends, One (1) 1" Female NPT 316L Stainless Steel Injection Port.

Design Criteria: 1400 gpm minimum flow, 2800 gpm normal flow, 1cP viscosity, 1.0 SG, 68 degree F

Overall Length: 64 inches

Pressure Loss: 3.65 psi @ 2800 GPM

Manufacturer: Koflo

Manufacturer PN: 14-10S-3-3-13EP.I(1.0)

WesTech PN: 23414A1003-010

Quantity: One (1)

REV	REVISION DESCRIPTION	ECN	DESIGNER	APPROVER	DATE
THIS DRAWING IS PROPERTY OF WESTECH ENGINEERING, INC. AND IS TRANSMITTED IN CONFIDENCE. NEITHER RECEIPT NOR POSSESSION CONFERS OR TRANSFERS ANY RIGHTS TO REPRODUCE, USE, OR DISCLOSE IN WHOLE OR IN PART, DATA CONTAINED HEREIN FOR ANY PURPOSE WITHOUT THE WRITTEN PERMISSION OF WESTECH ENGINEERING, INC.					
DESIGNER	RE60	<b>TITLE</b> CATALOG & BULLETIN INFORMATION STATIC MIXER MT ROSE WATER TREATMENT PLANT  <b>CLIENT</b> TRUCKEE MEADOWS WATER AUTHORITY ~ PO 03422 STANTEC CONSULTING, INC. ~ SPECIFICATION 13160			
CHECKER	DA48				
APPROVER	DA48				
DATE	2018-05-03				
FILE: 23414A-DS11-STATIC MIXER.docx		PROJECT 23414A	DOCUMENT NUMBER 23414A-DS11	SHEET 1 OF 2	REV -

**STANTEC**  
**THIS PAGE ONLY**  
**NO EXCEPTION TAKEN**

# CATALOG & BULLETIN INFORMATION

This Page Intentionally Blank

REV	REVISION DESCRIPTION	ECN	DESIGNER	APPROVER	DATE
THIS DRAWING IS PROPERTY OF WESTECH ENGINEERING, INC. AND IS TRANSMITTED IN CONFIDENCE. NEITHER RECEIPT NOR POSSESSION CONFERS OR TRANSFERS ANY RIGHTS TO REPRODUCE, USE, OR DISCLOSE IN WHOLE OR IN PART, DATA CONTAINED HEREIN FOR ANY PURPOSE WITHOUT THE WRITTEN PERMISSION OF WESTECH ENGINEERING, INC.					
DESIGNER	RE60	<b>TITLE</b> CATALOG & BULLETIN INFORMATION STATIC MIXER MT ROSE WATER TREATMENT PLANT  <b>CLIENT</b> TRUCKEE MEADOWS WATER AUTHORITY ~ PO 03422 STANTEC CONSULTING, INC. ~ SPECIFICATION 13160			
CHECKER	DA48				
APPROVER	DA48				
DATE	2018-05-03				
FILE: 23414A-DS11-STATIC MIXER.docx		PROJECT 23414A	DOCUMENT NUMBER 23414A-DS11	SHEET 2 OF 2	REV -



Pressure Loss Curve  
WesTech  
Quote #: 59662.2  
Application 1: 23414A Mt. Rose WTP  
14-10S-3-3-13EP.I(1.0)

**STANTEC**  
**THIS PAGE ONLY**  
**NO EXCEPTION TAKEN**

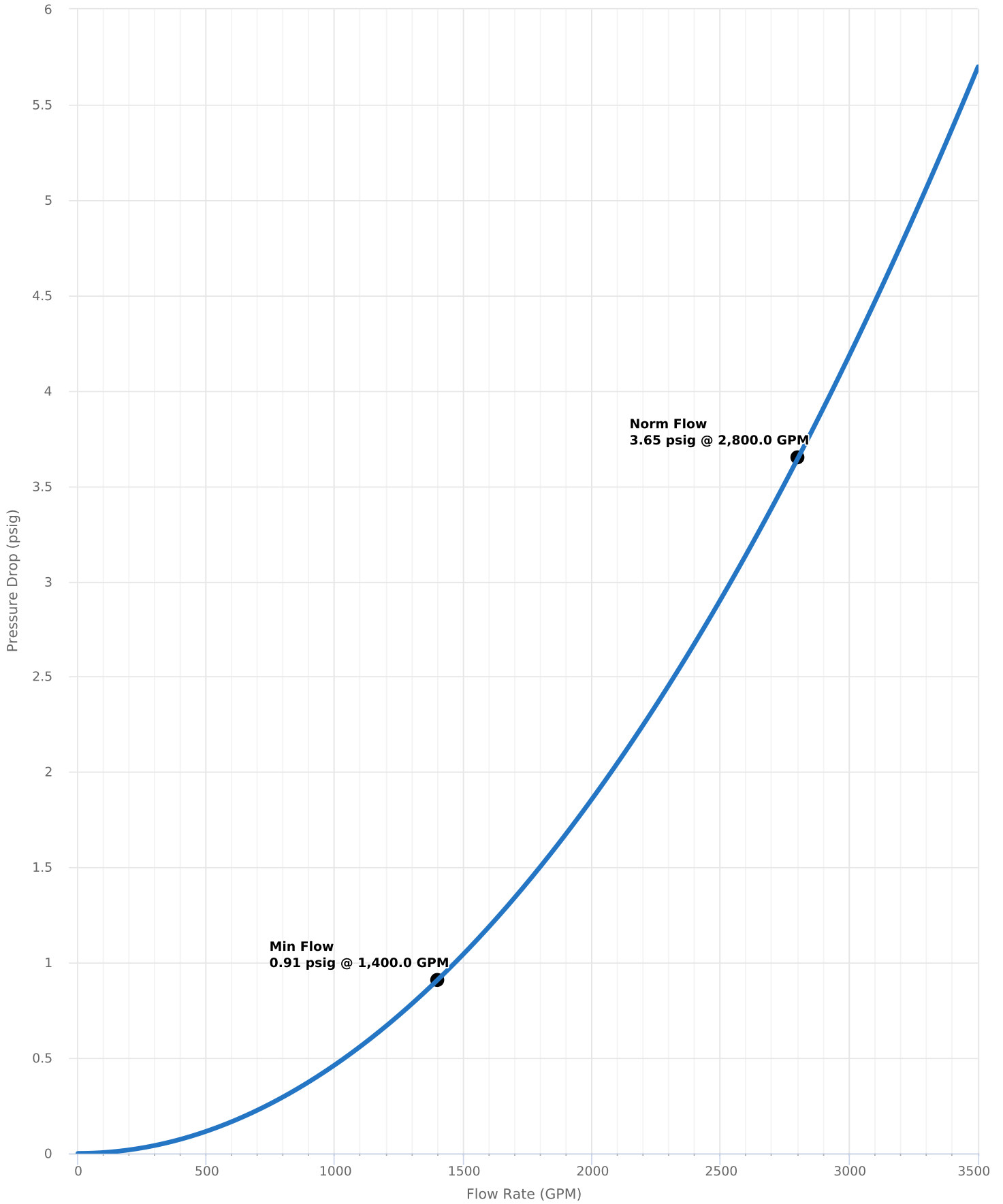

— 14-10S-3-3-13EP.I(1.0)



**HOMOGENEITY CHART**  
**QUOTE# 59662.2**  
**STATIC MIXER**  
**MODEL# 14-10S-3-3-13EP.I(1.0)**

**STANTEC**  
**THIS PAGE ONLY**  
**NO EXCEPTION TAKEN**

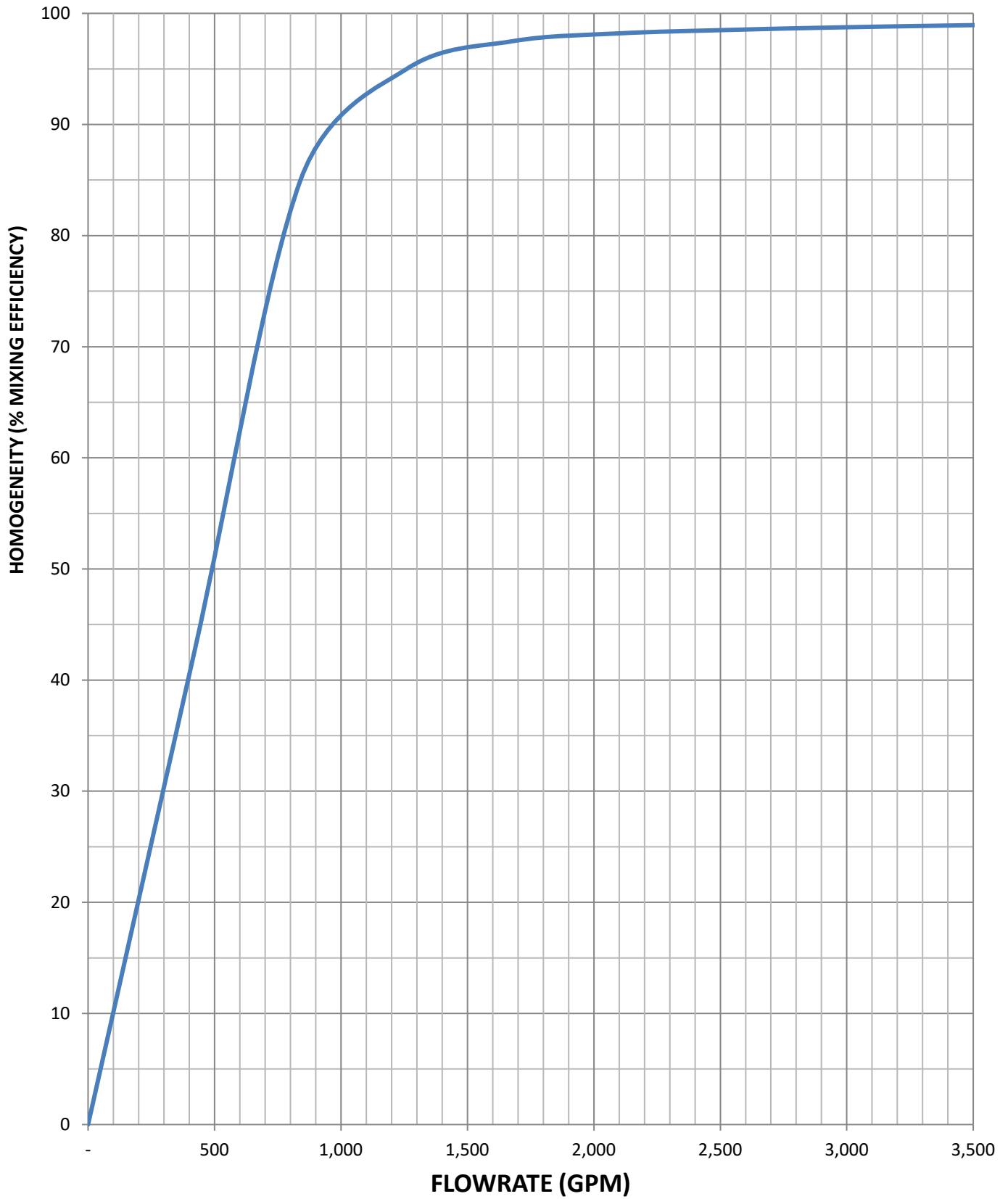

**STANTEC**  
**THIS PAGE ONLY**  
**NO EXCEPTION TAKEN**

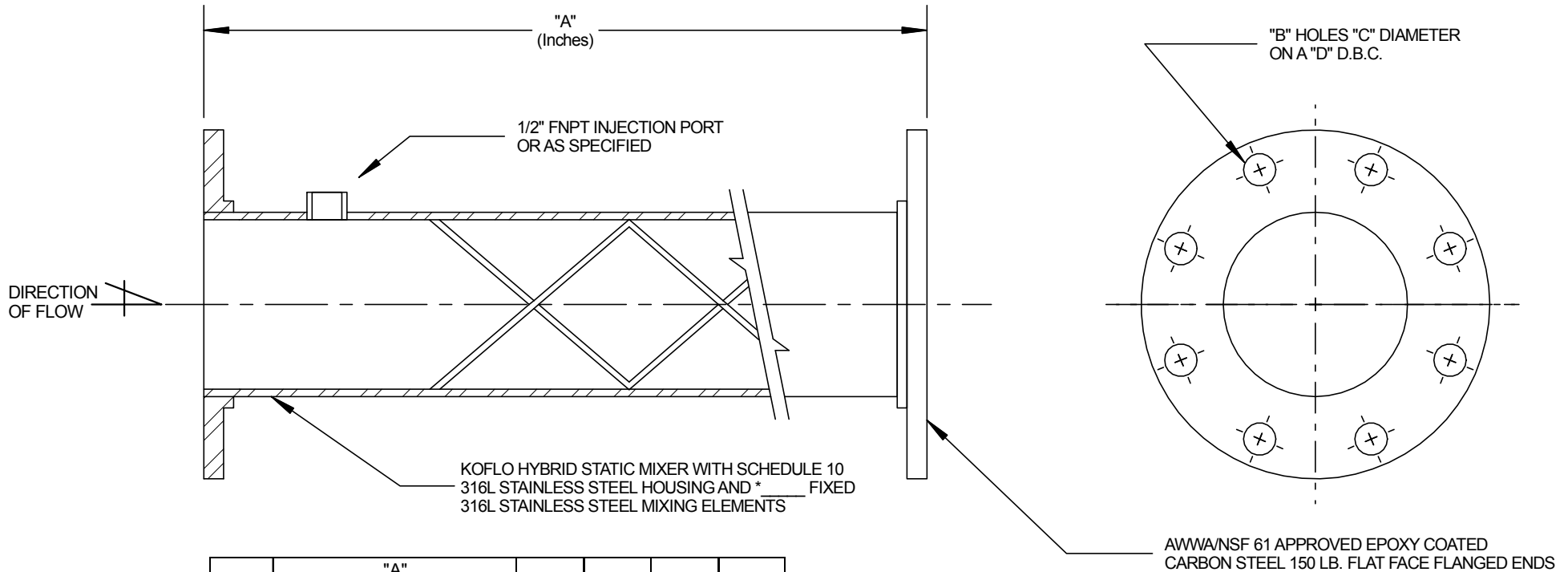

SIZE	"A"					"B"	"C"	"D"	"E"
	*NUMBER OF ELEMENTS								
	2	3	4	5	6				
3"	15	18	22	27	31	4	3/4"	6"	4"
4"	18	23	28	33	40	8	3/4"	7-1/2"	4"
6"	24	32	40	48	56	8	7/8"	9-1/2"	4"
8"	29	40	51	62	74	8	7/8"	11-3/4"	5"
10"	34	48	62	75	90	12	1"	14-1/4"	5"
12"	42	58	74	90	108	12	1"	17"	6"
14"	46	64	81	99	116	12	1-1/8"	18-3/4"	6"
16"	52	72	93	113	~	16	1-1/8"	21-1/4"	7"
18"	57	80	103	~	~	16	1-1/4"	22-3/4"	7"
20"	64	89	114	~	~	20	1-1/4"	25"	8"
24"	74	105	135	~	~	20	1-3/8"	29-1/2"	8"

<b>Koflo</b>		Koflo Corporation 309 CARY POINT DR. CARY, IL 60013	
SCALE: NONE	APPROVED BY	<i>JLF</i>	
DATE: 5/19/16			
CUSTOMER:		DRAWN BY NJF	
		REVISED	
		REVISED	
		REVISED	
MODEL NO: HYBRID MIXER FOR DUCTILE IRON LINES WITH FNPT INJECTION PORT		DRAWING NUMBER: KD-952	

This Page Intentionally Blank

**STANTEC**  
**THIS PAGE ONLY**  
**NO EXCEPTION TAKEN**

# CATALOG & BULLETIN INFORMATION

## PAINT SYSTEM

Description: Pota-Pox Plus Series N140 Polyamidoamine Epoxy  
 Manufacturer: Tnemec  
 Manufacturer PN: N140 or N140F (Fast Cure)  
 Colors Used: Primer (Interior and Exterior) 1255 – Beige  
 Interior Finish Coat: 15BL – Tank White

**Note:**

Fast Cure and Standard Cure are considered equal for service protection and its use is left to the tank fabricator's discretion.

The following recoat times apply for Series N140:

Immersion Service—Surface must be scarified after 60 days.

Atmospheric Service - After 60 days, scarification or an epoxy tie-coat is required.

The following recoat times apply for Series N140F:

Immersion Service—Surface must be scarified after 30 days.

Atmospheric Service - After 30 days, scarification or an epoxy tie-coat is required.

REV	REVISION DESCRIPTION	ECN	DESIGNER	APPROVER	DATE
THIS DRAWING IS PROPERTY OF WESTECH ENGINEERING, INC. AND IS TRANSMITTED IN CONFIDENCE. NEITHER RECEIPT NOR POSSESSION CONFERS OR TRANSFERS ANY RIGHTS TO REPRODUCE, USE, OR DISCLOSE IN WHOLE OR IN PART, DATA CONTAINED HEREIN FOR ANY PURPOSE WITHOUT THE WRITTEN PERMISSION OF WESTECH ENGINEERING, INC.					
DESIGNER	RE60	TITLE <b>CATALOG &amp; BULLETIN INFORMATION</b> <b>PAINT SYSTEM</b> <b>MT ROSE WATER TREATMENT PLANT</b>  CLIENT <b>TRUCKEE MEADOWS WATER AUTHORITY ~ PO 03422</b> <b>STANTEC CONSULTING, INC. ~ SPECIFICATION 13160</b>			
CHECKER	DA48				
APPROVER	DA48				
DATE	2018-05-03				
FILE: 23414A-DS12-PAINT INFORMATION.docx		PROJECT 23414A	DOCUMENT NUMBER 23414A-DS12	SHEET 1 OF 2	REV -

**STANTEC**  
**THIS PAGE ONLY**  
**NO EXCEPTION TAKEN**

# CATALOG & BULLETIN INFORMATION

This Page Intentionally Blank

REV	REVISION DESCRIPTION	ECN	DESIGNER	APPROVER	DATE
<small>THIS DRAWING IS PROPERTY OF WESTECH ENGINEERING, INC. AND IS TRANSMITTED IN CONFIDENCE. NEITHER RECEIPT NOR POSSESSION CONFERS OR TRANSFERS ANY RIGHTS TO REPRODUCE, USE, OR DISCLOSE IN WHOLE OR IN PART, DATA CONTAINED HEREIN FOR ANY PURPOSE WITHOUT THE WRITTEN PERMISSION OF WESTECH ENGINEERING, INC.</small>					
DESIGNER	RE60	<b>TITLE</b> CATALOG & BULLETIN INFORMATION PAINT SYSTEM MT ROSE WATER TREATMENT PLANT  <b>CLIENT</b> TRUCKEE MEADOWS WATER AUTHORITY ~ PO 03422 STANTEC CONSULTING, INC. ~ SPECIFICATION 13160			
CHECKER	DA48				
APPROVER	DA48				
DATE	2018-05-03				
FILE: 23414A-DS12-PAINT INFORMATION.docx		<b>PROJECT</b> 23414A	<b>DOCUMENT NUMBER</b> 23414A-DS12	<b>SHEET</b> 2 OF 2	<b>REV</b> -

# CATALOG & BULLETIN INFORMATION

## PAINT SYSTEMS

Description: Pota-Pox Plus Series N140 Polyamidoamine Epoxy  
 Manufacturer: Tnemec  
 Manufacturer PN: N140 or N140F (Fast Cure)  
 Colors Used: Primer (Interior and Exterior) 1255 – Beige  
 Interior Finish Coat: 15BL – Tank White

*Note:*

1. *Fast Cure and Standard Cure are considered equal for service protection and its use is left to the tank fabricator's discretion.*
2. *The following recoat times apply for Series N140:*
  - a. *Immersion Service—Surface must be scarified after 60 days.*
  - b. *Atmospheric Service - After 60 days, scarification or an epoxy tie-coat is required.*
3. *The following recoat times apply for Series N140F:*
  - a. *Immersion Service—Surface must be scarified after 30 days.*
  - b. *Atmospheric Service - After 30 days, scarification or an epoxy tie-coat is required.*

REV	REVISION DESCRIPTION	ECN	DESIGNER	APPROVER	DATE
THIS DRAWING IS PROPERTY OF WESTECH ENGINEERING, INC. AND IS TRANSMITTED IN CONFIDENCE. NEITHER RECEIPT NOR POSSESSION CONFERS OR TRANSFERS ANY RIGHTS TO REPRODUCE, USE, OR DISCLOSE IN WHOLE OR IN PART, DATA CONTAINED HEREIN FOR ANY PURPOSE WITHOUT THE WRITTEN PERMISSION OF WESTECH ENGINEERING, INC.					
DESIGNER	M096	TITLE CATALOG & BULLETIN INFORMATION PAINT SYSTEMS ADAIRSVILLE WTP & SPRING HOUSE IMPROVEMENTS			
CHECKER	DA48				
APPROVER	DA48	CLIENT FS360 ~ PO AWTP-01 RINDT-MCDUFF ASSOCIATES ~ SPECIFICATION 11220			
DATE	2017/12/22				
FILE: 23350A-DS06-Paint Systems.docx		PROJECT 23350A	DOCUMENT NUMBER 23350A-DS06	SHEET 1 OF 2	REV -

**STANTEC**  
**THIS PAGE ONLY**  
**NO EXCEPTION TAKEN**

# CATALOG & BULLETIN INFORMATION

*This Page Intentionally Blank*

REV	REVISION DESCRIPTION	ECN	DESIGNER	APPROVER	DATE
THIS DRAWING IS PROPERTY OF WESTECH ENGINEERING, INC. AND IS TRANSMITTED IN CONFIDENCE. NEITHER RECEIPT NOR POSSESSION CONFERS OR TRANSFERS ANY RIGHTS TO REPRODUCE, USE, OR DISCLOSE IN WHOLE OR IN PART, DATA CONTAINED HEREIN FOR ANY PURPOSE WITHOUT THE WRITTEN PERMISSION OF WESTECH ENGINEERING, INC.					
DESIGNER	M096	<b>TITLE</b> CATALOG & BULLETIN INFORMATION PAINT SYSTEMS ADAIRSVILLE WTP & SPRING HOUSE IMPROVEMENTS  <b>CLIENT</b> FS360 ~ PO AWTP-01 RINDT-MCDUFF ASSOCIATES ~ SPECIFICATION 11220			
CHECKER	DA48				
APPROVER	DA48				
DATE	2017/12/22				
FILE: 23350A-DS06-Paint Systems.docx		PROJECT 23350A	DOCUMENT NUMBER 23350A-DS06	SHEET 2 OF 2	REV -



# POTA-POX® PLUS

PRODUCT DATA SHEET

STANTEC

THIS PAGE ONLY  
NO EXCISE TAX TAKEN

## PRODUCT PROFILE

- GENERIC DESCRIPTION** Polyamidoamine Epoxy
- COMMON USAGE** Innovative potable water coating which offers high-build edge protection and allows for application at a wide range of temperatures (down to 35°F or 2°C with 44-700 Accelerator). For use on the interior and exterior of steel or concrete tanks, reservoirs, pipes, valves, pumps and equipment in potable water service.
- COLORS** 1211 Red, 1255 Beige, 00WH Tnemec White, 15BL Tank White, 35GR Black and 39BL Delft Blue. **Note:** Epoxies chalk with extended exposure to sunlight. Lack of ventilation, incomplete mixing, miscatalyzation or the use of heaters that emit carbon dioxide and carbon monoxide during application and initial stages of curing may cause yellowing to occur.
- SPECIAL QUALIFICATIONS** **Certified by NSF International in accordance with ANSI/NSF Std. 61.** Ambient air cured Series N140 (with or without 44-700 Epoxy Accelerator) is qualified for use on tanks and reservoirs of 1,000 gallons (3,785 L) capacity or greater, pipes 18 inches (46 cm) in diameter or greater, valves four (4) inches (10 cm) in diameter or greater and fittings four (4) inches (10 cm) in diameter or greater. Conforms to **AWWA D 102 Inside Systems No. 1 and No. 2** (with or without 44-700). Conforms to **AWWA C 210** (without 44-700). Contact your Tnemec representative for systems and additional information. A two-coat system at 4.0-6.0 dry mils (100-150 dry microns) per coat passes the performance requirements of MIL-PRF-4556F for fuel storage. Reference the "Search Listings" section of the NSF website at [www.nsf.org](http://www.nsf.org) for details on the maximum allowable DFT.
- PERFORMANCE CRITERIA** Extensive test data available. Contact your Tnemec representative for specific test results.

## COATING SYSTEM

- SURFACER/FILLER/PATCHER** 215, 217, 218
- PRIMERS** Self-priming, 22, 91-H<sub>2</sub>O, 94-H<sub>2</sub>O, L140, L140F, N140F, V140, V140F, 141
- TOPCOATS** **Interior:** Series 22, FC22, L140, L140F, N140, N140F, V140, V140F, 141, 406.  
**Exterior:** Series 27, 66, L69, L69F, N69, N69F, V69, V69F, 72, 73, L140, L140F, N140, N140F, V140, V140F, 156, 157, 161, 175, 180, 181, 446, 740, 750, 1028, 1029, 1074, 1074U, 1075, 1075U, 1077, 1078, 1080, 1081. Refer to COLORS on applicable topcoat data sheets for additional information. **Note: The following recoat times apply for Series N140:**  
**Immersion Service—Surface must be scarified by blasting with fine abrasive after 60 days. Atmospheric Service—After 60 days, scarification or an epoxy tie-coat is required.** When topcoating with Series 740 or 750, recoat time for N140 is 21 days. Contact your Tnemec representative for specific recommendations.

## SURFACE PREPARATION

- PRIMED STEEL** **Immersion Service:** Scarify the epoxy prime coat surface by abrasive blasting with fine abrasive before topcoating if it has been exterior exposed for 60 days or longer and N140 is the specified topcoat.
- STEEL** **Immersion Service:** SSPC-SP10/NACE 2 Near-White Blast Cleaning with a minimum angular anchor profile of 1.5 mils. **Non-Immersion Service:** SSPC-SP6/NACE 3 Commercial Blast Cleaning with a minimum angular anchor profile of 1.5 mils.
- CAST/DUCTILE IRON** Contact your Tnemec representative or Tnemec Technical Services.
- CONCRETE** Allow new concrete to cure 28 days. For optimum results and/or immersion service, abrasive blast referencing SSPC-SP13/NACE 6, ICRI-CSP 2-4 Surface Preparation of Concrete and Tnemec's Surface Preparation and Application Guide. Fill all holes, pits, voids and cracks with 215, 217 or 218.
- ALL SURFACES** Must be clean, dry and free of oil, grease and other contaminants.

## TECHNICAL DATA

- VOLUME SOLIDS** 67.0 ± 2.0% (mixed—A, B & 44-700 Epoxy Accelerator) †
- RECOMMENDED DFT** 2.0 to 10.0 mils (50 to 225 microns) per coat. **Note:** MIL-PRF-4556F applications require two coats at 4.0-6.0 mils (100-150 microns) per coat. Otherwise, the number of coats and thickness requirements will vary with substrate, application method and exposure. Contact your Tnemec representative.

**CURING TIME AT 5 MILS DFT** Without 44-700 Accelerator:

Temperature	To Handle	To Recoat	Immersion
90°F (32°C)	5 hours	7 hours	7 days
80°F (27°C)	7 hours	9 hours	7 days
70°F (21°C)	9 hours	12 hours	7 days
60°F (16°C)	16 hours	22 hours	9 to 12 days
50°F (10°C)	24 hours	32 hours	12 to 14 days

Curing time varies with surface temperature, air movement, humidity and film thickness. **Note:** For valve applications allow 14 days cure at 75°F (24°C) prior to immersion. For pipe applications allow 30 days cure at 75°F (24°C) prior to immersion. **Ventilation:** When used in enclosed areas, provide adequate ventilation during application and cure. **Note:** Refer to product listing on [www.nsf.org](http://www.nsf.org) for specific potable water return to service information. **Note:** For faster curing and low temperature applications, add No. 44-700 Epoxy Accelerator, see separate product data sheet for cure information.

- VOLATILE ORGANIC COMPOUNDS** **Unthinned:** 2.4 lbs/gallon (285 grams/litre)  
**Thinned 5% (#60):** 2.6 lbs/gallon (311 grams/litre)  
**Thinned 10% (#4):** 2.8 lbs/gallon (334 grams/litre) †
- HAPS** **Unthinned:** 2.4 lbs/gal solids **Thinned 5% (#60):** 2.4 lbs/gal solids  
**Thinned 10% (#4):** 3.3 lbs/gal solids
- THEORETICAL COVERAGE** 1,070 mil sq ft/gal (27.2 m<sup>2</sup>/L at 25 microns). See APPLICATION for coverage rates. †
- NUMBER OF COMPONENTS** Two: Part A (amine) and Part B (epoxy) — One (Part A) to one (Part B) by volume.

PRODUCT DATA SHEET  
STANTEC  
**POTA-POX® PLUS | SERIES N140**  
THIS PAGE ONLY  
NO EXCEPTION TAKEN

<b>PACKAGING</b>	5 gallon (18.9L) pails and 1 gallon (3.79L) cans - Order in multiples of 2. Reference 44-700 Epoxy Accelerator product data sheet for its packaging information.
<b>NET WEIGHT PER GALLON</b>	12.66 ± 0.25 lbs (5.82 ± .11 kg) (mixed) †
<b>STORAGE TEMPERATURE</b>	Minimum 20°F (-7°C) Maximum 110°F (43°C)
<b>TEMPERATURE RESISTANCE</b>	(Dry) Continuous 250°F (121°C) Intermittent 275°F (135°C)
<b>SHelf LIFE</b>	Part A: 24 months; Part B: 12 months at recommended storage temperature.
<b>FLASH POINT - SETA</b>	Part A: 82°F (28°C) Part B: 80°F (27°C) 44-700: None
<b>HEALTH &amp; SAFETY</b>	Paint products contain chemical ingredients which are considered hazardous. Read container label warning and Material Safety Data Sheet for important health and safety information prior to the use of this product. <b>Keep out of reach of children.</b>

**APPLICATION**

COVERAGE RATES	Dry MILS (Microns)	Wet MILS (Microns)	Sq Ft/Gal (m <sup>2</sup> /Gal)
Suggested	6.0 (150)	9.0 (230)	179 (16.6)
Minimum	2.0 (50)	3.0 (75)	537 (49.9)
Maximum	10.0 (225)	15.0 (375)	107 (10.0)

**Note:** Roller or brush application requires two or more coats to obtain recommended film thickness. Allow for overspray and surface irregularities. Wet film thickness is rounded to the nearest 0.5 mil or 5 microns. Application of coating below minimum or above maximum recommended dry film thicknesses may adversely affect coating performance. Reference the "Search Listings" section of the NSF website at [www.nsf.org](http://www.nsf.org) for details on the maximum allowable DFT. †

- MIXING**
- Start with equal amounts of both Parts A & B.
  - Using a power mixer, separately stir Parts A & B.
  - (For accelerated version. If not using 44-700, skip to No. 4.) Add four (4) fluid ounces of 44-700 per gallon of Part A while Part A is under agitation.
  - Add Part A to Part B under agitation, stir until thoroughly mixed.
  - Both components must be above 50°F (10°C) prior to mixing. For application of the unaccelerated version to surfaces between 50°F to 60°F (10°C to 16°C) or the accelerated version to surfaces between 35°F to 50°F (2°C to 10°C), allow mixed material to stand 30 minutes and restir before using.
  - For optimum application properties, the material temperature should be above 60°F (16°C).
- Note:** The use of more than the recommended amount of 44-700 will adversely affect performance.

**THINNING** Use No. 4 or No. 60 Thinner. For air spray, thin up to 10% or 3/4 pint (380 mL) per gallon with No. 4 Thinner or thin up to 5% or 1/4 pint (190 mL) per gallon with No. 60 Thinner. For airless spray, roller or brush, thin up to 5% or 1/4 pint (190 mL) per gallon. **Caution: Series N140 NSF certification is based on thinning with No. 4 or No. 60 Thinner for tanks and only No. 60 Thinner for pipe, valves and fittings.** Use of any other thinner voids ANSI/NSF Std. 61 certification.

**POT LIFE** Without 44-700 6 hours at 50°F (10°C) 4 hours at 75°F (24°C) 1 hour at 100°F (38°C)  
With 44-700 2 hours at 50°F (10°C) 1 hour at 75°F (24°C) 30 minutes at 100°F (38°C)

**SPRAY LIFE** Without 44-700: 1 hour at 77°F (25°C) With 44-700: 30 minutes at 75°F (24°C)

**Note:** Spray application after listed times will adversely affect ability to achieve recommended dry film thickness.

**APPLICATION EQUIPMENT**

**Air Spray**

Gun	Fluid Tip	Air Cap	Air Hose ID	Mat'l Hose ID	Atomizing Pressure	Pot Pressure
DeVilbiss JGA	E	765 or 704	5/16" or 3/8" (7.9 or 9.5 mm)	3/8" or 1/2" (9.5 or 12.7 mm)	75-100 psi (5.2-6.9 bar)	10-20 psi (0.7-1.4 bar)

**Airless Spray**

Tip Orifice	Atomizing Pressure	Mat'l Hose ID	Manifold Filter
0.015"-0.019" (380-485 microns)	3000-4800 psi (207-330 bar)	1/4" or 3/8" (6.4 or 9.5 mm)	60 mesh (250 microns)

Low temperatures or longer hoses require higher pot pressure. Use appropriate tip/atomizing pressure for equipment, applicator technique and weather conditions.

**Roller:** Use 3/8" or 1/2" (9.5 mm to 12.7 mm) synthetic woven nap roller cover. Use longer nap to obtain penetration on rough or porous surfaces.

**Brush:** Recommended for small areas only. Use high quality natural or synthetic bristle brushes.

**SURFACE TEMPERATURE** Without 44-700: Min. 50°F (10°C), Max. 135°F (57°C) With 44-700: Min. 35°F (2°C), Max. 135°F (57°C)  
The surface should be dry and at least 5°F (3°C) above the dew point. Coating will not cure below minimum surface temperature.

**CLEANUP** Flush and clean all equipment immediately after use with the recommended thinner or MEK.  
† Values may vary with color.

WARRANTY & LIMITATION OF SELLER'S LIABILITY: Tnemec Company, Inc. warrants only that its coatings represented herein meet the formulation standards of Tnemec Company, Inc. THE WARRANTY DESCRIBED IN THE ABOVE PARAGRAPH SHALL BE IN LIEU OF ANY OTHER WARRANTY, EXPRESSED OR IMPLIED, INCLUDING BUT NOT LIMITED TO, ANY IMPLIED WARRANTY OF MERCHANTABILITY OR FITNESS FOR A PARTICULAR PURPOSE. THERE ARE NO WARRANTIES THAT EXTEND BEYOND THE DESCRIPTION ON THE FACE HEREOF. The buyer's sole and exclusive remedy against Tnemec Company, Inc. shall be for replacement of the product in the event a defective condition of the product should be found to exist and the exclusive remedy shall not have failed its essential purpose as long as Tnemec is willing to provide comparable replacement product to the buyer. NO OTHER REMEDY (INCLUDING, BUT NOT LIMITED TO, INCIDENTAL OR CONSEQUENTIAL DAMAGES FOR LOST PROFITS, LOST SALES, INJURY TO PERSON OR PROPERTY, ENVIRONMENTAL INJURIES OR ANY OTHER INCIDENTAL OR CONSEQUENTIAL LOSS) SHALL BE AVAILABLE TO THE BUYER. Technical and application information herein is provided for the purpose of establishing a general profile of the coating and proper coating application procedures. Test performance results were obtained in a controlled environment and Tnemec Company makes no claim that these tests or any other tests, accurately represent all environments. As application, environmental and design factors can vary significantly, due care should be exercised in the selection and use of the coating.

Tnemec Company Incorporated 6800 Corporate Drive Kansas City, Missouri 64120-1372 1-800-TNEMEC1 Fax: 1-816-483-3969 [www.tnemec.com](http://www.tnemec.com)



# POTA-POX® PLUS SERIES N140F

## PRODUCT PROFILE

**GENERIC DESCRIPTION** Polyamidoamine Epoxy

**COMMON USAGE** Innovative potable water coating which offers high-build edge protection and allows for application at a wide range of temperatures (down to 35°F or 2°C). For use on the interior and exterior of steel or concrete tanks, reservoirs, pipes, valves, pumps and equipment in potable water service.

**COLORS** 1211 Red, 1255 Beige, 00WH Tnemec White, 15BL Tank White, 39BL Delft Blue, 35GR Black. **Note:** Epoxies chalk with extended exposure to sunlight. Lack of ventilation, incomplete mixing, miscatalyzation or the use of heaters that emit carbon dioxide and carbon monoxide during application and initial stages of curing may cause yellowing to occur.

**SPECIAL QUALIFICATIONS** **Certified by NSF International in accordance with NSF/ANSI Std. 61.** Ambient air cured Series N140F is qualified for use on tanks and reservoirs of 1,000 gallons (3,785 L) capacity or greater, pipes 18 inches (46 cm) in diameter or greater and valves four (4) inches (10 cm) in diameter or greater. Series N140F is certified by **NSF International** in accordance with **NSF/ANSI Std. 50** for pools and other recreational water facilities. Conforms to **AWWA D 102 Inside Systems No. 1 and No. 2**. Contact your Tnemec representative for systems and additional information. A two-coat system at 4.0-6.0 dry mils (100-150 dry microns) per coat passes the performance requirements of MIL-PRF-4556F for fuel storage. Reference the "Search Listings" section of the NSF website at [www.nsf.org](http://www.nsf.org) for details on the maximum allowable DFT.

**PERFORMANCE CRITERIA** Extensive test data available. Contact your Tnemec representative for specific test results.

## COATING SYSTEM

**SURFACER/FILLER/PATCHER** 215, 217, 218

**PRIMERS** Self-priming, 22, 91-H<sub>2</sub>O, 94-H<sub>2</sub>O, L140, L140F, N140, V140, 141

**TOPCOATS** **Interior:** Series 22, FC22, L140, L140F, N140, N140F, V140, V140F, 141, 406  
**Exterior:** Series 27, 66, L69, L69F, N69, N69F, V69, V69F, 72, 73, L140, L140F, N140, N140F, V140, V140F, 156, 157, 161, 175, 180, 181, 446, 740, 750, 1028, 1029, 1074, 1074U, 1075, 1075U, 1077, 1078, 1080, 1081. Refer to COLORS on applicable topcoat data sheets for additional information. **Note: The following recoat times apply for Series N140F:**  
**Immersion Service—Surface must be scarified by blasting with fine abrasive after 30 days. Atmospheric Service—After 30 days, scarification or an epoxy tie-coat is required.** When topcoating with Series 740 or 750, recoat time for N140F is 14 days. Contact your Tnemec representative for specific recommendations.

## SURFACE PREPARATION

**PRIMED STEEL** **Immersion Service:** Scarify the epoxy prime coat surface by abrasive blasting with fine abrasive before topcoating if it has been exterior exposed for 30 days or longer and N140F is the specified topcoat.

**STEEL** **Immersion Service:** SSPC-SP10/NACE 2 Near-White Blast Cleaning with a minimum angular anchor profile of 1.5 mils  
**Non-Immersion Service:** SSPC-SP6/NACE 3 Commercial Blast Cleaning with a minimum angular anchor profile of 1.5 mils.

**CAST/DUCTILE IRON** Contact your Tnemec Representative or Tnemec Technical Services.

**CONCRETE** Allow new concrete to cure 28 days. For optimum results and/or immersion service, abrasive blast referencing SSPC-SP13/NACE 6, ICRI-CSP 2-4 Surface Preparation of Concrete and Tnemec's Surface Preparation and Application Guide. Fill all holes, pits, voids and cracks with 215 or 218.

**ALL SURFACES** Must be clean, dry and free of oil, grease and other contaminants.

## TECHNICAL DATA

**VOLUME SOLIDS** 68.0 ± 2.0% (mixed) †

**RECOMMENDED DFT** 2.0 to 10.0 mils (50 to 225 microns) per coat. **Note:** MIL-PRF-4556F applications require two coats at 4.0-6.0 mils (100-150 microns) per coat. Otherwise, the number of coats and thickness requirements will vary with substrate, application method and exposure. Contact your Tnemec representative.

### CURING TIME AT 5 MILS DFT

Temperature	To Handle	To Recoat	Immersion
75°F (24°C)	4 hours	5 hours	7 days
65°F (18°C)	7-8 hours	9-11 hours	8 days
55°F (13°C)	12-14 hours	16-20 hours	9-10 days
45°F (7°C)	18-22 hours	28-32 hours	12-13 days
35°F (2°C)	28-32 hours	46-50 hours	16-18 days

Curing time varies with surface temperature, air movement, humidity and film thickness.  
**Note:** For valve applications allow 14 days cure at 75°F (24°C) prior to immersion. For pipe applications allow 30 days cure at 75°F (24°C) prior to immersion. **Ventilation:** When used in enclosed areas, provide adequate ventilation during application and cure. **Note:** Refer to product listings on [www.nsf.org](http://www.nsf.org) for specific potable water return to service information.

### VOLATILE ORGANIC COMPOUNDS

**Unthinned:** 2.3 lbs/gallon (273 grams/litre)  
**Thinned 5% (#60):** 2.5 lbs/gallon (299 grams/litre)  
**Thinned 10% (#4):** 2.7 lbs/gallon (323 grams/litre) †

### HAPS

**Unthinned:** 2.3 lbs/gal solids  
**Thinned 5% (#60):** 2.3 lbs/gal solids  
**Thinned 10% (#4):** 3.1 lbs/gal solids

### THEORETICAL COVERAGE

1,094 mil sq ft/gal (26.8 m<sup>2</sup>/L at 25 microns). See APPLICATION for coverage rates. †

### NUMBER OF COMPONENTS

Two: Part A (amine) and Part B (epoxy) — One (Part A) to one (Part B) by volume.

### PACKAGING

5 gallon (18.9L) pails and 1 gallon (3.79L) cans — Order in multiples of 2.

PRODUCT DATA SHEET  
STANTEC  
DIN PAGE ONLY  
**NO EXCEPTION TAKEN**

# POTA-POX® PLUS | SERIES N140F

<b>NET WEIGHT PER GALLON</b>	12.68 ± 0.25 lbs (5.75 ± .11 kg) (mixed) †
<b>STORAGE TEMPERATURE</b>	Minimum 20°F (-7°C) Maximum 110°F (43°C) For optimum application properties, material temperature should be above 60°F (16°C) prior to application.
<b>TEMPERATURE RESISTANCE</b>	(Dry) Continuous 250°F (121°C) Intermittent 275°F (135°C)
<b>SHELF LIFE</b>	Part A: 24 months; Part B: 12 months at recommended storage temperature.
<b>FLASH POINT - SETA</b>	Part A: 82°F (28°C) Part B: 80°F (27°C)
<b>HEALTH &amp; SAFETY</b>	Paint products contain chemical ingredients which are considered hazardous. Read container label warning and Material Safety Data Sheet for important health and safety information prior to the use of this product. <b>Keep out of the reach of children.</b>

## APPLICATION

### COVERAGE RATES

	Dry MILS (Microns)	Wet MILS (Microns)	Sq Ft/Gal (m <sup>2</sup> /Gal)
Suggested	6.0 (150)	9.0 (230)	182 (16.9)
Minimum	2.0 (50)	3.0 (75)	545 (50.7)
Maximum	10.0 (225)	15.0 (375)	109 (10.1)

**Note:** Roller or brush application requires two or more coats to obtain recommended film thickness. Allow for overspray and surface irregularities. Wet film thickness is rounded to the nearest 0.5 mil or 5 microns. Application of coating below minimum or above maximum recommended dry film thicknesses may adversely affect coating performance. Reference the "Search Listings" section of the NSF website at [www.nsf.org](http://www.nsf.org) for details on the maximum allowable DFT. †

### MIXING

1. Start with equal amounts of both Parts A & B.
2. Using a power mixer, separately stir Parts A & B.
3. Add Part A to Part B under agitation, stir until thoroughly mixed.
4. Both components should be above 50°F (10°C) prior to mixing. For application to surfaces between 35°F to 50°F (2°C to 10°C), allow mixed material to stand thirty (30) minutes and restir before using. For optimum application properties, blended components should be above 40°F (4°C).

### THINNING

N140F: Use No. 4 or No. 60 Thinner. For air spray, thin up to 10% or 3/4 pint (380 mL) per gallon with No. 4 Thinner or thin up to 5% or 1/4 pint (190 mL) per gallon with No. 60 Thinner. For airless spray, roller or brush, thin up to 5% or 1/4 pint (190 mL) per gallon. **Caution: Series N140F NSF certification is based on thinning with No. 4 or No. 60 Thinner for tanks and only No. 60 Thinner for pipe and valves.** Use of any other thinner voids NSF/ANSI Std. 61 certification. V140F: Use No. 4 Thinner. **Caution: Series V140F NSF certification is based on thinning with No. 4 Thinner only.** Use of any other thinner voids NSF/ANSI Std. 61 certification. **Note:** When using Series V140F, a maximum of 4.5% of No. 4 Thinner may be used to comply with VOC regulations.

### POT LIFE

2 hours at 50°F (10°C) 1 hour at 75°F (24°C) 30 minutes at 100°F (38°C)

### SPRAY LIFE

30 minutes at 75°F (24°C)

**Note:** Spray application after listed times will adversely affect ability to achieve recommended dry film thickness.

### APPLICATION EQUIPMENT

#### Air Spray

Gun	Fluid Tip	Air Cap	Air Hose ID	Mat'l Hose ID	Atomizing Pressure	Pot Pressure
DeVilbiss JGA	E	765 or 704	5/16" or 3/8" (7.9 or 9.5 mm)	3/8" or 1/2" (9.5 or 12.7 mm)	75-100 psi (5.2-6.9 bar)	10-20 psi (0.7-1.4 bar)

Low temperatures or longer hoses require higher pot pressure.

#### Airless Spray

Tip Orifice	Atomizing Pressure	Mat'l Hose ID	Manifold Filter
0.015"-0.019" (380-485 microns)	3000-4800 psi (207-330 bar)	1/4" or 3/8" (6.4 or 9.5 mm)	60 mesh (250 microns)

Use appropriate tip/atomizing pressure for equipment, applicator technique and weather conditions.

**Roller:** Use 3/8" or 1/2" (9.5 mm to 12.7 mm) synthetic woven nap roller cover. Use longer nap to obtain penetration on rough or porous surfaces.

**Brush:** Recommended for small areas only. Use high quality natural or synthetic bristle brushes.

### SURFACE TEMPERATURE

Minimum 35°F (2°C) Maximum 135°F (57°C)

The surface should be dry and at least 5°F (3°C) above the dew point. Coating won't cure below minimum surface temperature.

### CLEANUP

Flush and clean all equipment immediately after use with the recommended thinner or MEK.

† Values may vary with color.

WARRANTY & LIMITATION OF SELLER'S LIABILITY: Tnemec Company, Inc. warrants only that its coatings represented herein meet the formulation standards of Tnemec Company, Inc. THE WARRANTY DESCRIBED IN THE ABOVE PARAGRAPH SHALL BE IN LIEU OF ANY OTHER WARRANTY, EXPRESSED OR IMPLIED, INCLUDING BUT NOT LIMITED TO, ANY IMPLIED WARRANTY OF MERCHANTABILITY OR FITNESS FOR A PARTICULAR PURPOSE. THERE ARE NO WARRANTIES THAT EXTEND BEYOND THE DESCRIPTION ON THE FACE HEREOF. The buyer's sole and exclusive remedy against Tnemec Company, Inc. shall be for replacement of the product in the event a defective condition of the product should be found to exist and the exclusive remedy shall not have failed its essential purpose as long as Tnemec is willing to provide comparable replacement product to the buyer. NO OTHER REMEDY (INCLUDING, BUT NOT LIMITED TO, INCIDENTAL OR CONSEQUENTIAL DAMAGES FOR LOST PROFITS, LOST SALES, INJURY TO PERSON OR PROPERTY, ENVIRONMENTAL INJURIES OR ANY OTHER INCIDENTAL OR CONSEQUENTIAL LOSS) SHALL BE AVAILABLE TO THE BUYER. Technical and application information herein is provided for the purpose of establishing a general profile of the coating and proper coating application procedures. Test performance results were obtained in a controlled environment and Tnemec Company makes no claim that these tests or any other tests, accurately represent all environments. As application, environmental and design factors can vary significantly, due care should be exercised in the selection and use of the coating.

Tnemec Company Incorporated 6800 Corporate Drive Kansas City, Missouri 64120-1372 1-800-TNEMEC1 Fax: 1-816-483-3969 [www.tnemec.com](http://www.tnemec.com)

## CATALOG & BULLETIN INFORMATION

### CLARIFIER AND FILTER MEDIA

Clarifier Media

Description: Media, Adsorption Clarifier, 50% virgin/50% rolled and scarified, NSF 61 approved. Shipped in gaylords

Bed Depth: 48 inches

WesTech PN: 2-6992

Quantity: 748 cubic feet, (374 cubic feet per unit)

Weight: 37 lb per cubic foot

Filter Media

Description: Filter Anthracite, 1.0-1.1 mm effective size, 1.7 uniformity coefficient maximum, 1.4 minimum specific gravity, comply with latest AWWA B-100 standard. Media shall consist of hard, durable and dense grains.

Bed Depth: 18 inches

WesTech PN: 2-4804

Quantity: 850 cubic feet, (425 cubic feet per unit) (quantity provided includes ~1% excess for skimming)

Weight: 53 lb per cubic foot

Description: Filter Sand, silica, 0.35-0.45 mm effective size, 1.4 uniformity coefficient maximum, minimum specific gravity of 2.60, complies with latest AWWA B-100 standard. Media shall consist of hard, durable and dense grains.

Bed Depth: 9 inches

WesTech PN: 2-11029

Quantity: 442 cubic feet, (221 cubic feet per unit) (quantity provided includes ~5% excess for skimming)

Weight: 100 lb per cubic foot

REV	REVISION DESCRIPTION	ECN	DESIGNER	APPROVER	DATE
THIS DRAWING IS PROPERTY OF WESTECH ENGINEERING, INC. AND IS TRANSMITTED IN CONFIDENCE. NEITHER RECEIPT NOR POSSESSION CONFERS OR TRANSFERS ANY RIGHTS TO REPRODUCE, USE, OR DISCLOSE IN WHOLE OR IN PART, DATA CONTAINED HEREIN FOR ANY PURPOSE WITHOUT THE WRITTEN PERMISSION OF WESTECH ENGINEERING, INC.					
DESIGNER	RE60	<b>TITLE</b> CATALOG & BULLETIN INFORMATION CLARIFIER AND FILTER MEDIA MT ROSE WATER TREATMENT PLANT <b>CLIENT</b> TRUCKEE MEADOWS WATER AUTHORITY ~ PO 03422 STANTEC CONSULTING, INC. ~ SPECIFICATION 13160			
CHECKER	DA48				
APPROVER	DA48				
DATE	2018-05-03				
FILE: 23414A-DS13-CLARIFIER AND FILTER MEDIA.docx		PROJECT 23414A	DOCUMENT NUMBER 23414A-DS13	SHEET 1 OF 2	REV -

## CATALOG & BULLETIN INFORMATION

Description: Filter Garnet, 0.2-0.32 mm effective size, 1.7 uniformity coefficient maximum, minimum specific gravity of 3.8, complies with latest AWWA B-100 standard. Media shall consist of hard, durable and dense grains.

Bed Depth: 3 inches

WesTech PN: 2-5953

Quantity: 148 cubic feet, (74 cubic feet per unit) (quantity provided includes ~5% excess for skimming)

Weight: 122 lb per cubic foot

Description: Garnet Fill, 0.2-0.32 mm effective size, 1.7 uniformity coefficient maximum, minimum specific gravity of 3.8, complies with latest AWWA B-100 standard. Media shall consist of hard, durable and dense grains.

Bed Depth: Fill to top of underdrain laterals

WesTech PN: 2-5953

Quantity: 148 cubic feet, (74 cubic feet per unit)

Weight: 122 lb per cubic foot

Note: All quantities of filtering media shipped include overage to provide an effective depth of 30 inches above lateral after installation.

REV	REVISION DESCRIPTION	ECN	DESIGNER	APPROVER	DATE
THIS DRAWING IS PROPERTY OF WESTECH ENGINEERING, INC. AND IS TRANSMITTED IN CONFIDENCE. NEITHER RECEIPT NOR POSSESSION CONFERS OR TRANSFERS ANY RIGHTS TO REPRODUCE, USE, OR DISCLOSE IN WHOLE OR IN PART, DATA CONTAINED HEREIN FOR ANY PURPOSE WITHOUT THE WRITTEN PERMISSION OF WESTECH ENGINEERING, INC.					
DESIGNER	RE60	<b>TITLE</b> CATALOG & BULLETIN INFORMATION CLARIFIER AND FILTER MEDIA MT ROSE WATER TREATMENT PLANT <b>CLIENT</b> TRUCKEE MEADOWS WATER AUTHORITY ~ PO 03422 STANTEC CONSULTING, INC. ~ SPECIFICATION 13160			
CHECKER	DA48				
APPROVER	DA48				
DATE	2018-05-03				
FILE: 23414A-DS13-CLARIFIER AND FILTER MEDIA.docx		PROJECT 23414A	DOCUMENT NUMBER 23414A-DS13	SHEET 2 OF 2	REV -

# CATALOG & BULLETIN INFORMATION

## WESTECH NSF LISTINGS

Adsorption Clarifier Media  
 Underdrain Nozzle

REV	REVISION DESCRIPTION	ECN	DESIGNER	APPROVER	DATE
<small>THIS DRAWING IS PROPERTY OF WESTECH ENGINEERING, INC. AND IS TRANSMITTED IN CONFIDENCE. NEITHER RECEIPT NOR POSSESSION CONFERS OR TRANSFERS ANY RIGHTS TO REPRODUCE, USE, OR DISCLOSE IN WHOLE OR IN PART, DATA CONTAINED HEREIN FOR ANY PURPOSE WITHOUT THE WRITTEN PERMISSION OF WESTECH ENGINEERING, INC.</small>					
DESIGNER	RE60	TITLE CATALOG & BULLETIN INFORMATION WESTECH NSF LISTINGS MT ROSE WATER TREATMENT PLANT CLIENT TRUCKEE MEADOWS WATER AUTHORITY ~ PO 03422 STANTEC CONSULTING, INC. ~ SPECIFICATION 13160			
CHECKER	DA48				
APPROVER	DA48				
DATE	2018-05-03				
FILE: 23414A-DS14- WESTECH NSF LISTINGS.docx		PROJECT 23414A	DOCUMENT NUMBER 23414A-DS14	SHEET 1 OF 2	REV -

**STANTEC**  
**THIS PAGE ONLY**  
**NO EXCEPTION TAKEN**

# CATALOG & BULLETIN INFORMATION

This Page Intentionally Blank

REV	REVISION DESCRIPTION	ECN	DESIGNER	APPROVER	DATE
<small>THIS DRAWING IS PROPERTY OF WESTECH ENGINEERING, INC. AND IS TRANSMITTED IN CONFIDENCE. NEITHER RECEIPT NOR POSSESSION CONFERS OR TRANSFERS ANY RIGHTS TO REPRODUCE, USE, OR DISCLOSE IN WHOLE OR IN PART, DATA CONTAINED HEREIN FOR ANY PURPOSE WITHOUT THE WRITTEN PERMISSION OF WESTECH ENGINEERING, INC.</small>					
DESIGNER	RE60	<b>TITLE</b> CATALOG & BULLETIN INFORMATION WESTECH NSF LISTINGS MT ROSE WATER TREATMENT PLANT  <b>CLIENT</b> TRUCKEE MEADOWS WATER AUTHORITY ~ PO 03422 STANTEC CONSULTING, INC. ~ SPECIFICATION 13160			
CHECKER	DA48				
APPROVER	DA48				
DATE	2018-05-03				
<small>FILE: 23414A-DS14- WESTECH NSF LISTINGS.docx</small>		<small>PROJECT</small> 23414A	<small>DOCUMENT NUMBER</small> 23414A-DS14	<small>SHEET</small> 2 OF 2	<small>REV</small> -



The Public Health and Safety Organization

## NSF Product and Service Listings

These NSF Official Listings are current as of **Sunday, May 13, 2018** at 12:15 a.m. Eastern Time. Please contact NSF International to confirm the status of any Listing, report errors, or make suggestions.

Alert: NSF is concerned about fraudulent downloading and manipulation of website text. Always confirm this information by clicking on the below link for the most accurate information: <http://info.nsf.org/Certified/PwsComponents/Listings.asp?Company=C0144301&Standard=061&>

### NSF/ANSI 61 Drinking Water System Components - Health Effects

**NOTE: Unless otherwise indicated for Materials, Certification is only for the Water Contact Material shown in the Listing. Click here for a list of Abbreviations used in these Listings. Click here for the definitions of Water Contact Temperatures denoted in these Listings.**

WesTech Engineering, Inc.  
600 Arrasmith Trail  
Ames, IA 50010  
United States  
515-268-8521

**Facility :** New Bedford, MA

#### Process Media

Trade Designation	Size	Water Contact Temp	Water Contact Material
Adsorption Clarifier® Media[1]	2.5 mm - 2.8 mm	CLD 23	PE

#### Adsorption Media

[1] Certification is based on a bed size of 2-4 cubic feet with a minimum flow rate of 10 gpm per square foot.

NOTE: Certified for water treatment plant applications.  
This product has not been evaluated for point of use applications.

**Facility :** West Jordan, UT

**Process Media**

<b>Trade Designation</b>	<b>Size</b>	<b>Water Contact Temp</b>	<b>Water Contact Material</b>
<b>Adsorption Media[1]</b> Compressible Media	40mm - 50mm	CLD 23	SYN

[1] Media use not to exceed 1450 g/ft<sup>2</sup> in a vertical column, and for a minimum flow rate of 5 gpm/ft<sup>2</sup>.

<b>Clarifier Media[1]</b> Compressible Media	40mm - 50mm	CLD 23	SYN
---	-------------	--------	-----

[1] Media use not to exceed 1450 g/ft<sup>2</sup> in a vertical column, and for a minimum flow rate of 5 gpm/ft<sup>2</sup>.

NOTE: Certified for water treatment plant applications.  
This product has not been evaluated for point of use applications.

---

Number of matching Manufacturers is 1

Number of matching Products is 3

Processing time was 0 seconds



The Public Health and Safety Organization

## NSF Product and Service Listings

These NSF Official Listings are current as of **Sunday, May 13, 2018** at 12:15 a.m. Eastern Time. Please contact NSF International to confirm the status of any Listing, report errors, or make suggestions.

Alert: NSF is concerned about fraudulent downloading and manipulation of website text. Always confirm this information by clicking on the below link for the most accurate information:

<http://info.nsf.org/Certified/PwsComponents/Listings.asp?Company=C0357764&Standard=061&>

### NSF/ANSI 61 Drinking Water System Components - Health Effects

**NOTE: Unless otherwise indicated for Materials, Certification is only for the Water Contact Material shown in the Listing. Click here for a list of Abbreviations used in these Listings. Click here for the definitions of Water Contact Temperatures denoted in these Listings.**

#### WesTech Engineering, Inc.

600 Arrasmith Trail

Ames, IA 50010

United States

515-268-8400

Visit this company's website (<http://www.westech-inc.com>)

**Facility :** Freeport, IL

#### Mechanical Devices

Trade Designation	Size	Water Contact Temp	Water Contact Material
<b>Filter Underdrain</b>			
Concrete Insert	[1]	CLD 23	MLTPL
Underdrain Nozzle	[1]	CLD 23	MLTPL

[1] Certified sizes are as follows:

Concrete Insert - Multiple

Pan Form - 541 sq. in./sq. ft.

Underdrain Nozzle - 3014 sq. in./sq. ft.

**Water Treatment Devices**

Pan Form	[1]	CLD 23	MLTPL
Underdrain Nozzle	[1]	CLD 23	MLTPL

[1] Certified sizes are as follows:  
 Concrete Insert - Multiple  
 Pan Form - 541 sq. in./sq. ft.  
 Underdrain Nozzle - 3014 sq. in./sq. ft.

**Facility : Holiday City, OH**

**Mechanical Devices**

<b>Trade Designation</b>	<b>Size</b>	<b>Water Contact Temp</b>	<b>Water Contact Material</b>
<b>Filter Underdrain</b>			
Multiblock Filter Underdrain	[1]	CLD 23	PE
Multicrete II Pan Form	[2]	CLD 23	HDPE

[1] Certified for a minimum flow of 2 gallons/minute/square foot of filter surface area.  
 [2] Certified for a minimum flow of 1.5 gallons/minute/square foot of filter surface area.

---

Number of matching Manufacturers is 1  
 Number of matching Products is 6  
 Processing time was 0 seconds

# CATALOG & BULLETIN INFORMATION

## AWI UNDERDRAIN SYSTEM

Phoenix underdrain plenum to be factory installed with supervision by AWI representative.  
 Underdrain laterals are to be field installed with supervision by AWI representative.

Phoenix Underdrain General Arrangement: 2346-GA-001, (7) pages  
 Catalog Data Sheets (9) pages

REV	REVISION DESCRIPTION	ECN	DESIGNER	APPROVER	DATE
THIS DRAWING IS PROPERTY OF WESTECH ENGINEERING, INC. AND IS TRANSMITTED IN CONFIDENCE. NEITHER RECEIPT NOR POSSESSION CONFERS OR TRANSFERS ANY RIGHTS TO REPRODUCE, USE, OR DISCLOSE IN WHOLE OR IN PART, DATA CONTAINED HEREIN FOR ANY PURPOSE WITHOUT THE WRITTEN PERMISSION OF WESTECH ENGINEERING, INC.					
DESIGNER	RE60	TITLE CATALOG & BULLETIN INFORMATION AWI UNDERDRAIN SYSTEM MT ROSE WATER TREATMENT PLANT CLIENT TRUCKEE MEADOWS WATER AUTHORITY ~ PO 03422 STANTEC CONSULTING, INC. ~ SPECIFICATION 13160			
CHECKER	DA48				
APPROVER	DA48				
DATE	2018-05-03				
FILE: 23414A-DS15-AWI UNDERDRAIN SYSTEM.docx		PROJECT 23414A	DOCUMENT NUMBER 23414A-DS15	SHEET 1 OF 2	REV -

**STANTEC**  
**THIS PAGE ONLY**  
**NO EXCEPTION TAKEN**

# CATALOG & BULLETIN INFORMATION

This Page Intentionally Blank

REV	REVISION DESCRIPTION	ECN	DESIGNER	APPROVER	DATE
<small>THIS DRAWING IS PROPERTY OF WESTECH ENGINEERING, INC. AND IS TRANSMITTED IN CONFIDENCE. NEITHER RECEIPT NOR POSSESSION CONFERS OR TRANSFERS ANY RIGHTS TO REPRODUCE, USE, OR DISCLOSE IN WHOLE OR IN PART, DATA CONTAINED HEREIN FOR ANY PURPOSE WITHOUT THE WRITTEN PERMISSION OF WESTECH ENGINEERING, INC.</small>					
DESIGNER	RE60	<b>TITLE</b> CATALOG & BULLETIN INFORMATION AWI UNDERDRAIN SYSTEM MT ROSE WATER TREATMENT PLANT  <b>CLIENT</b> TRUCKEE MEADOWS WATER AUTHORITY ~ PO 03422 STANTEC CONSULTING, INC. ~ SPECIFICATION 13160			
CHECKER	DA48				
APPROVER	DA48				
DATE	2018-05-03				
<small>FILE: 23414A-DS15-AWI UNDERDRAIN SYSTEM.docx</small>		<small>PROJECT</small> 23414A	<small>DOCUMENT NUMBER</small> 23414A-DS15	<small>SHEET</small> 2 OF 2	<small>REV</small> -

# **GENERAL ARRANGEMENT DRAWINGS**

**For**

**Mount Rose Water Treatment Plant  
Truckee Meadows, Nevada**

**Phoenix Underdrain System**

**As supplied by:**

**Anthratch U.S.  
471 West Universal Circle  
Sandy, Utah 84070  
(801) 566-1700**

**“For Approval”**

**March 22, 2018**

**STANTEC  
THIS PAGE ONLY  
NO EXCEPTION TAKEN**

REVISION HISTORY					
REV	DESCRIPTION	DATE	BY	DATE	CHKD/DATE
A	INITIAL RELEASE				
B	CHANGED NOTE 1 & 2, SHEET 5. ADDED DIM & AIR REF ON DETAIL 4, SHEET 6.	03/19/18	KPS	03/22/18	BKT 03/22/18

STANTEC  
APPROVED  
THIS PAGE ONLY  
NO EXCEPTION TAKEN

DESIGN PARAMETER DESCRIPTION	VALUE	UNITS
NUMBER OF FILTERS	TWO (2)	-
NUMBER OF CELLS PER FILTER	ONE (1)	-
MINIMUM BACKWASH WATER FLOW RATE	5.0	GPM/FT <sup>2</sup>
MAXIMUM BACKWASH WATER FLOW RATE	15.0	GPM/FT <sup>2</sup>
MAXIMUM AIR SCOUR FLOW RATE	3.0	SCFM/FT <sup>2</sup>

FOR APPROVAL - 03/22/2018

**GENERAL NOTES:**

1. ALL DIMENSIONS SHOWN ARE TO BE VERIFIED BY THE CONTRACTOR.
2. ALL COMPONENTS SUPPLIED BY AWI TO BE 316L STAINLESS STEEL UNLESS OTHERWISE NOTED.
3. QUANTITIES SHOWN AND NOTED IN THE BILL OF MATERIALS REFLECT COMPONENTS FOR ONE (1) FILTER ONLY. AWI TO SUPPLY COMPONENTS FOR TWO (2) FILTERS.
4. MAXIMUM DIFFERENTIAL PRESSURE ACROSS THE UNDERDRAIN SYSTEM DURING BACKWASH IS NOT TO EXCEED 10 PSI. OPERATION OF THE UNDERDRAIN SYSTEM ABOVE A DIFFERENTIAL PRESSURE OF 10 PSI VOIDS THE AWI WARRANTY.
5. FOR INSTALLATION INSTRUCTIONS SEE O&M MANUAL.
6. FILTER TROUGHS NOT SHOWN FOR CLARITY.
7. FILTER MEDIA NOT SHOWN FOR CLARITY.

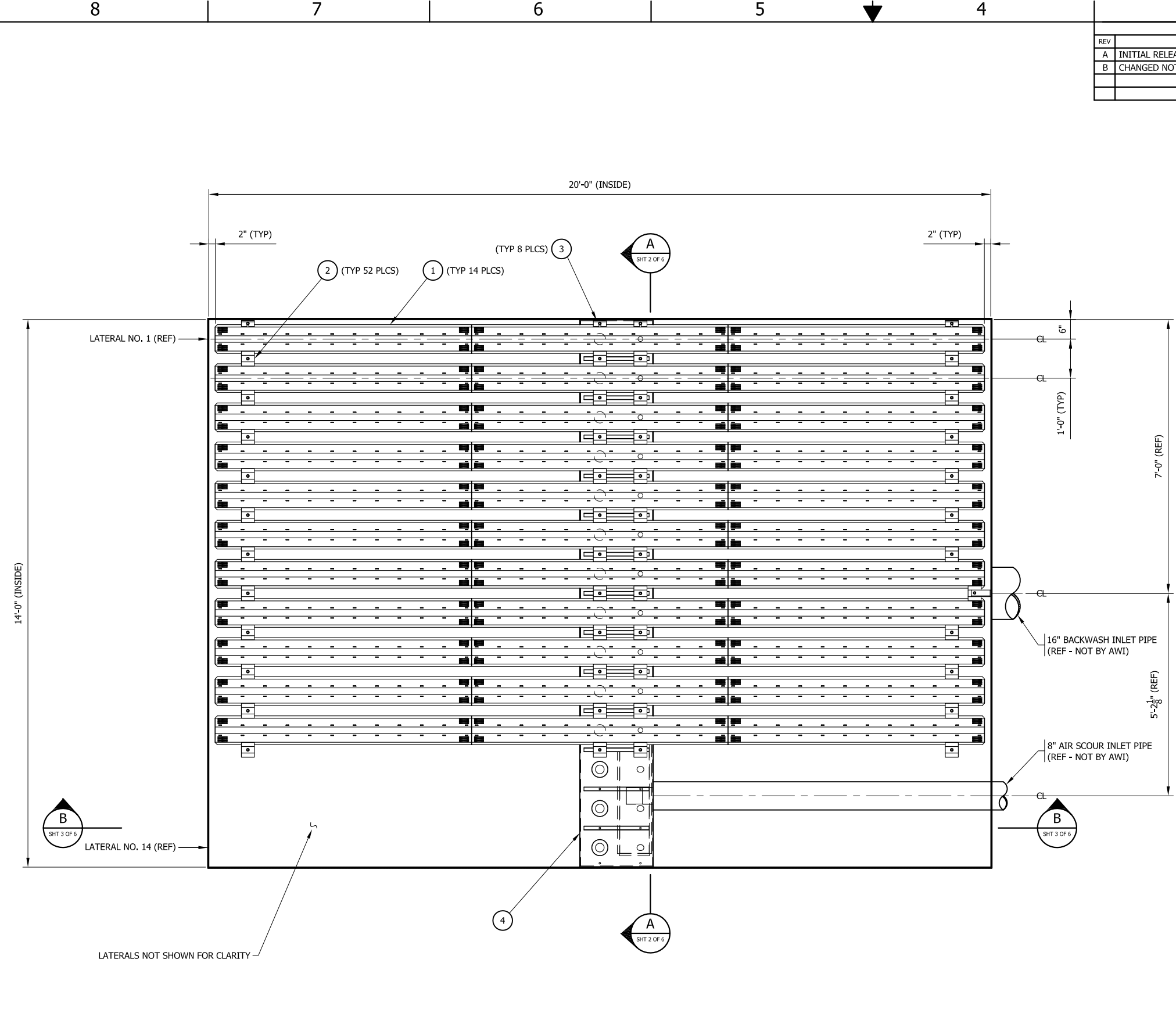

**PLAN VIEW**  
(TANK A)

ITEM NO.	QTY	PART NO.	DESCRIPTION	MATERIAL	MATERIAL SPEC.
15	AR	-	HILTI HIT HY-200 ADHESIVE	-	-
14	AR	-	SIKA 1A SEALANT	-	-
13	56	-	SHIM, (1/4")	HDPE	-
12	56	-	SHIM, (1/8")	HDPE	-
11	14	-	GASKET, 3/8" THICK X 5 1/2" DIAMETER	NSR	-
10	14	-	GASKET, 3/8" THICK X 9" DIAMETER	NSR	-
9	61	-	NUT, HEX, 1/2"-13UNC	316 SS	-
8	61	-	WASHER, LOCK, 1/2", REGULAR HELICAL SPRING	316 SS	-
7	61	-	WASHER, FLAT, 1/2", TYPE A PLAIN, NORMAL	316 SS	-
6	30	-	THREADED ROD, 1/2"-13UNC X 9 1/2" LONG	316 SS	-
5	1	-	WALL HOLD DOWN BRACKET, 2" X 2" X 1/4" ANGLE	316L SS	ASTM A276
4	1	-	BOX MANIFOLD	316L SS	ASTM A240
3	8	-	HOLD DOWN CLAMP, EDGE	316L SS	ASTM A276
2	52	-	HOLD DOWN CLAMP, STANDARD	316L SS	ASTM A276
1	14	-	PHOENIX UNDERDRAIN LATERAL, STANDARD, INLET	316L SS	ASTM A240

<p><small>DIMENSIONS AND SYMBOLOLOGY PER ASME Y14.5M - 1994 UNLESS OTHERWISE SPECIFIED</small></p> <p><small>SURFACE ROUGHNESS: 125</small></p> <p><small>TOLERANCES ARE IN INCHES</small></p> <p><small>TOLERANCES: .X = +.1          .XX = +.03          .XXX = +.010</small></p> <p><small>FRACTIONS: ± 1/16"</small></p> <p><small>ANGLES: ±.50°</small></p> <p><small>DO NOT SCALE DRAWING</small></p>	<table border="1"> <thead> <tr> <th>TASK</th> <th>INITIALS</th> <th>DATE</th> </tr> </thead> <tbody> <tr><td>MODELED</td><td>-</td><td>-</td></tr> <tr><td>DRAWN</td><td>KPS</td><td>02/26/18</td></tr> <tr><td>CHECKED</td><td>DKT</td><td>03/15/18</td></tr> <tr><td>APPROVED</td><td>DKT</td><td>03/15/18</td></tr> <tr><td>QA/QC</td><td>-</td><td>-</td></tr> </tbody> </table>	TASK	INITIALS	DATE	MODELED	-	-	DRAWN	KPS	02/26/18	CHECKED	DKT	03/15/18	APPROVED	DKT	03/15/18	QA/QC	-	-	<p style="text-align: center;"><b>AWI</b></p> <p style="text-align: center;"><b>GENERAL ARRANGEMENT</b> PHOENIX UNDERDRAIN SYSTEM MOUNT ROSE WTP TRUCKEE MEADOWS, NV</p> <table border="1" style="width: 100%;"> <tr> <td>SIZE</td> <td>CAGE CODE</td> <td>DWG NO</td> <td>REV</td> </tr> <tr> <td>D</td> <td>N/A</td> <td>2346-GA-001</td> <td>B</td> </tr> <tr> <td>SCALE</td> <td colspan="2">NONE</td> <td>SHEET 1 OF 7</td> </tr> </table>	SIZE	CAGE CODE	DWG NO	REV	D	N/A	2346-GA-001	B	SCALE	NONE		SHEET 1 OF 7
TASK	INITIALS	DATE																														
MODELED	-	-																														
DRAWN	KPS	02/26/18																														
CHECKED	DKT	03/15/18																														
APPROVED	DKT	03/15/18																														
QA/QC	-	-																														
SIZE	CAGE CODE	DWG NO	REV																													
D	N/A	2346-GA-001	B																													
SCALE	NONE		SHEET 1 OF 7																													

STANTEC  
THIS PAGE ONLY  
NO EXCEPTION TAKEN

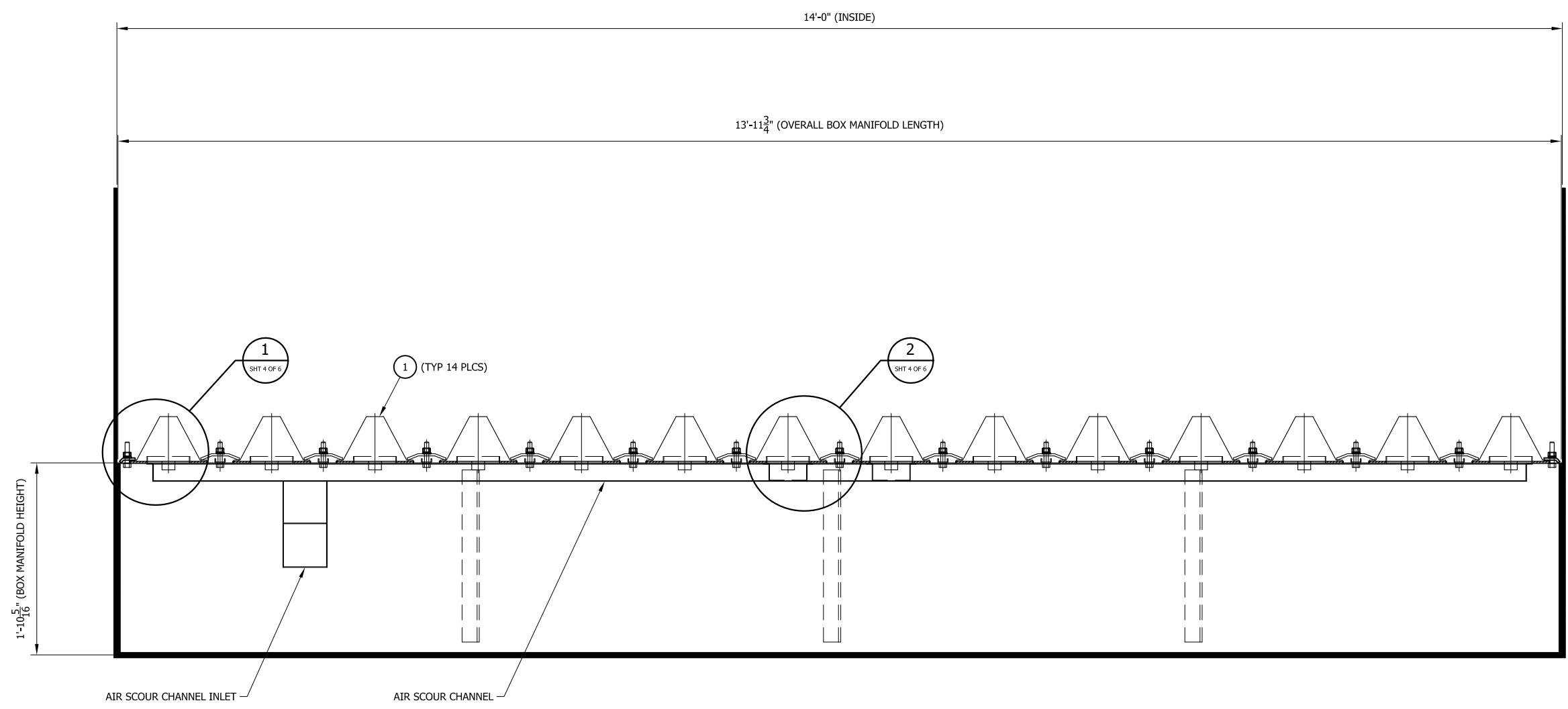

SECTION A-A  
SHT 1 OF 6

FOR APPROVAL - 03/22/2018

SIZE D	CAGE CODE N/A	DWG NO 2346-GA-001	REV B
SCALE NONE		SHEET 2 OF 7	

STANTEC  
THIS PAGE ONLY  
NO EXCEPTION TAKEN

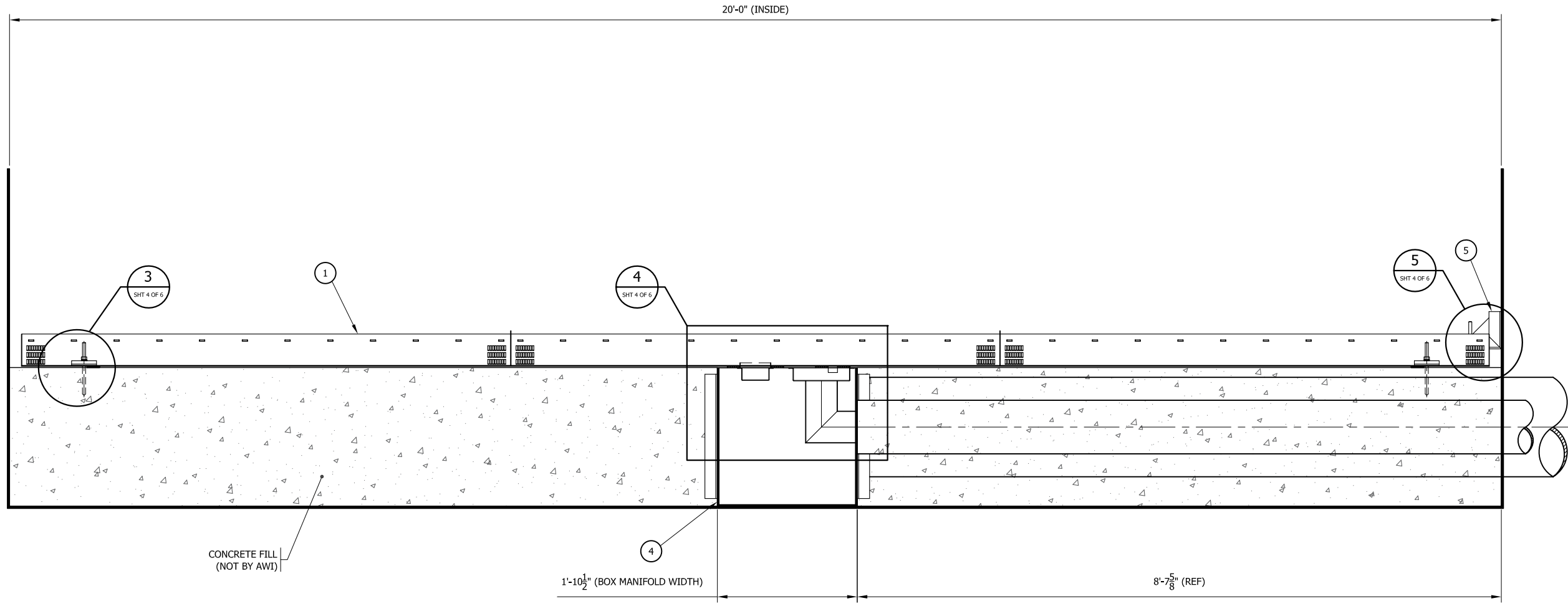

SECTION B-B  
SHT 1 OF 6

FOR APPROVAL - 03/22/2018

SIZE D	CAGE CODE N/A	DWG NO 2346-GA-001	REV B
SCALE NONE			SHEET 3 OF 7

**STANTEC**  
**THIS PAGE ONLY**  
**NO EXCEPTION TAKEN**

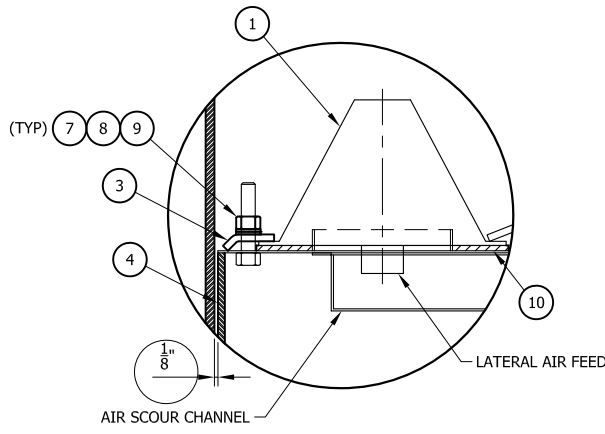

**DETAIL 1**  
 SH1 2 OF 6

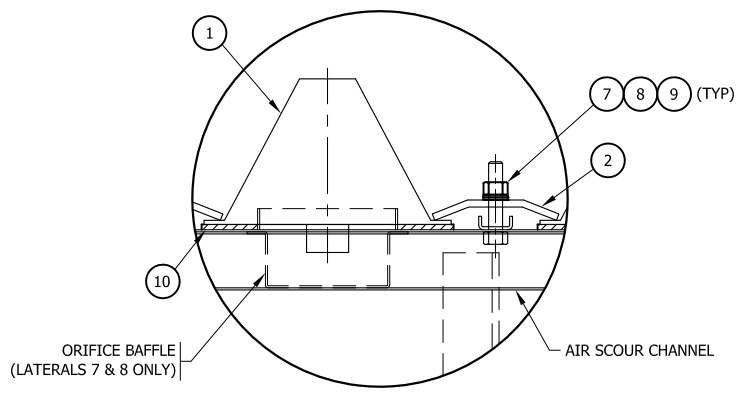

**DETAIL 2**  
 SH1 2 OF 6

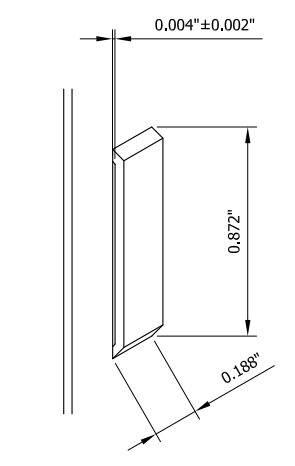

**SLOT DETAIL**

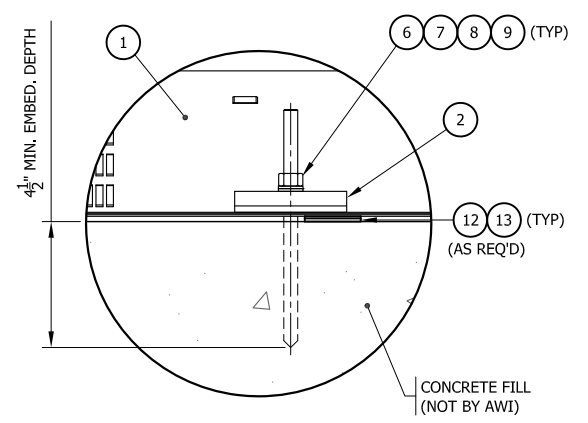

**DETAIL 3**  
 SH1 3 OF 6

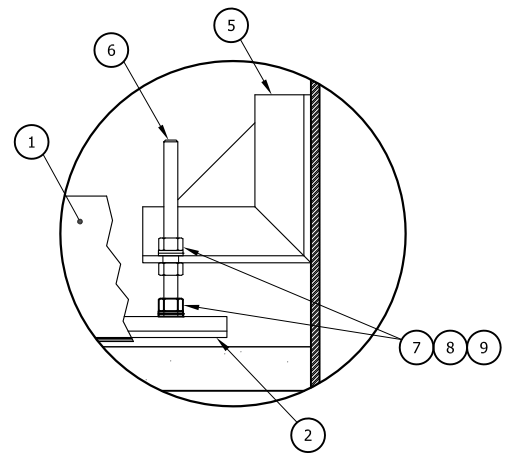

**DETAIL 5**  
 SH1 3 OF 6

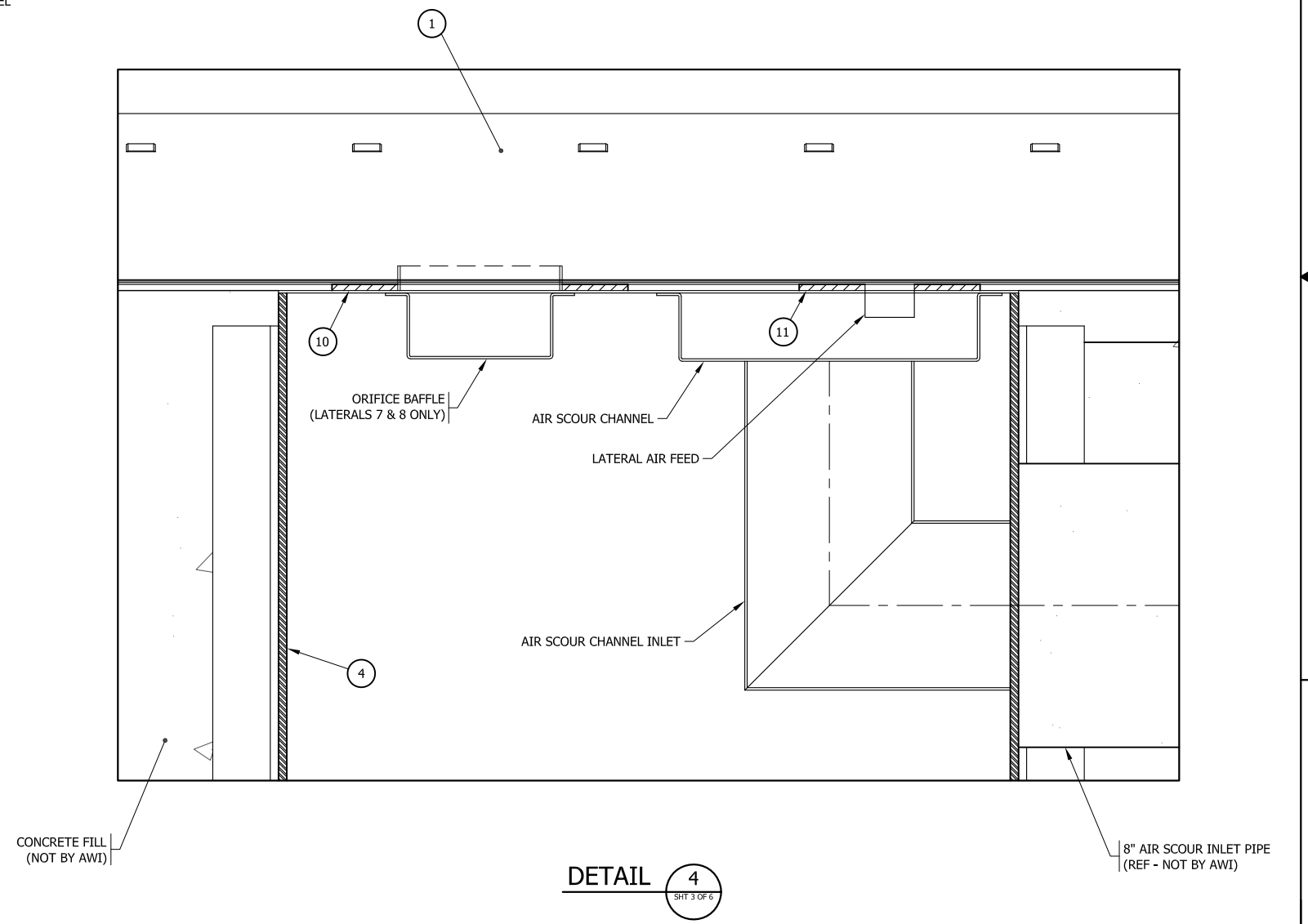

**DETAIL 4**  
 SH1 3 OF 6

FOR APPROVAL - 03/22/2018

SIZE D	CAGE CODE N/A	DWG NO 2346-GA-001	REV B
SCALE NONE		SHEET 4 OF 7	

**STANTEC**  
**THIS PAGE ONLY**  
**NO EXCEPTION TAKEN**

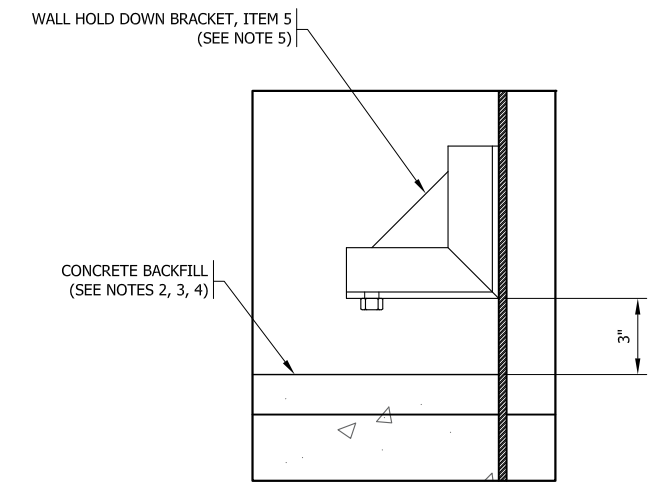
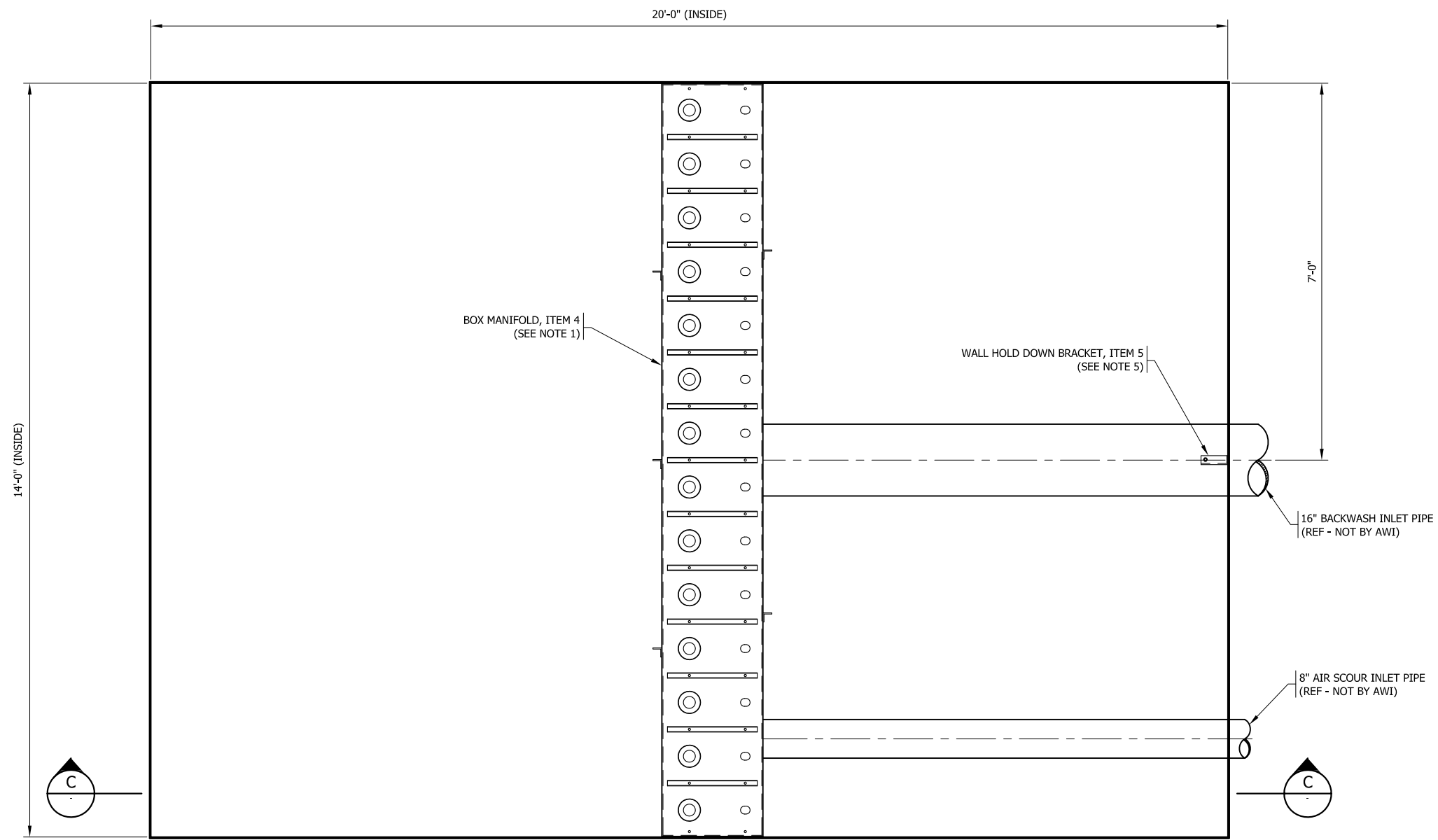

**DETAIL 8**

**PLAN VIEW - FILTER TANK PREPARATION**

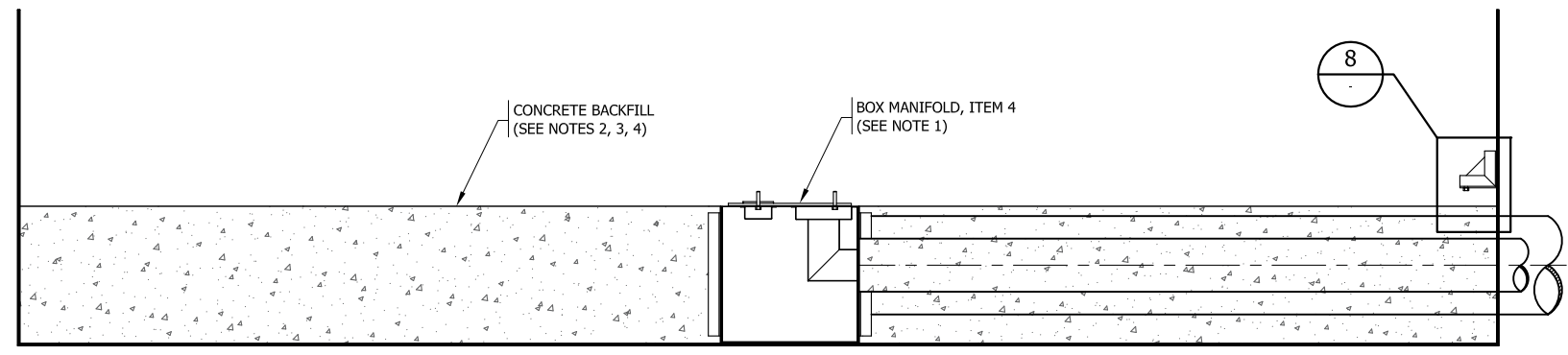

**SECTION C-C**

**NOTES:**

1. BOX MANIFOLD, ITEM 4, IS TO BE WELDED TO TANK AND INLET PIPING BY TANK FABRICATOR. NOT BY AWI.
2. CONCRETE BACKFILL TO BE POURED AFTER BOX MANIFOLD INSTALLATION. THE TOP SURFACE OF THE CONCRETE BACKFILL IS TO BE FINISHED LEVEL WITH TOP OF BOX MANIFOLD:  $+0' \pm \frac{1}{8}"$ . CONCRETE BACKFILL NOT BY AWI.
3. CONCRETE BACKFILL IS TO BE MIXED AND INSTALLED IN ACCORDANCE WITH MANUFACTURE'S SPECIFICATIONS.
4. CONCRETE BACKFILL IS TO BE FULLY BONDED TO TANK WITHOUT CRACKS OR DEFECTS.
5. WALL HOLD DOWN BRACKET, ITEM 5, TO BE CENTERED ON THE 14' TANK WALL. WALL HOLD DOWN BRACKET TO BE WELDED, BY CONTRACTOR OR OTHER, TO TANK WALL ABOVE BACKWASH INLET. NOT BY AWI.
6. TANK NOT BY AWI.

**FOR APPROVAL - 03/22/2018**

SIZE D	CAGE CODE N/A	DWG NO 2346-GA-001	REV B
SCALE NONE			SHEET 5 OF 7

**STANTEC  
THIS PAGE ONLY  
NO EXCEPTION TAKEN**

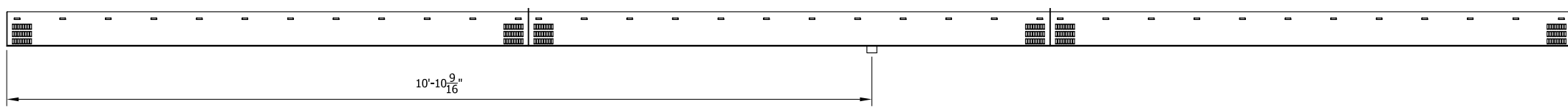
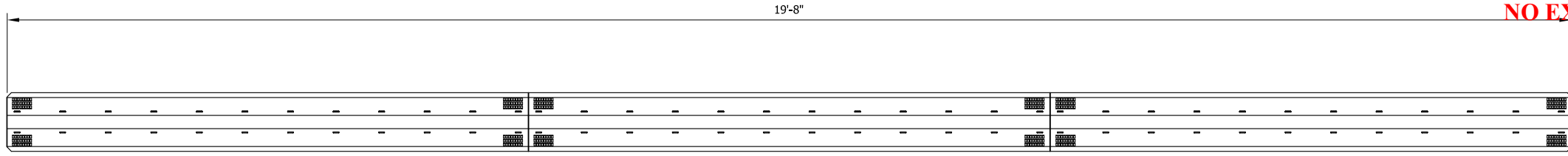

**DETAIL - ITEM 1**

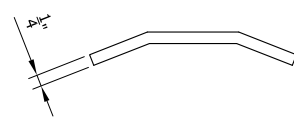
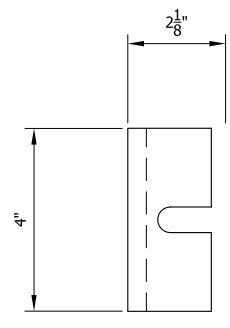
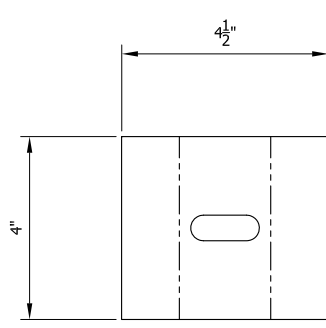
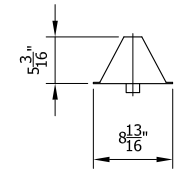

**DETAIL - ITEM 2**

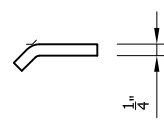

**DETAIL - ITEM 3**

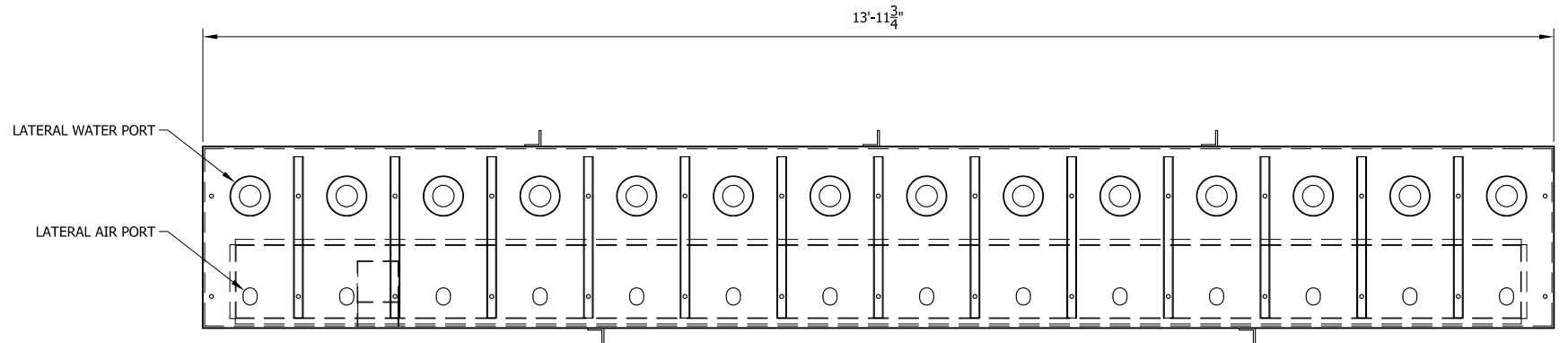

**DETAIL - ITEM 4**

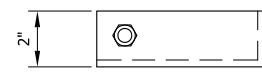
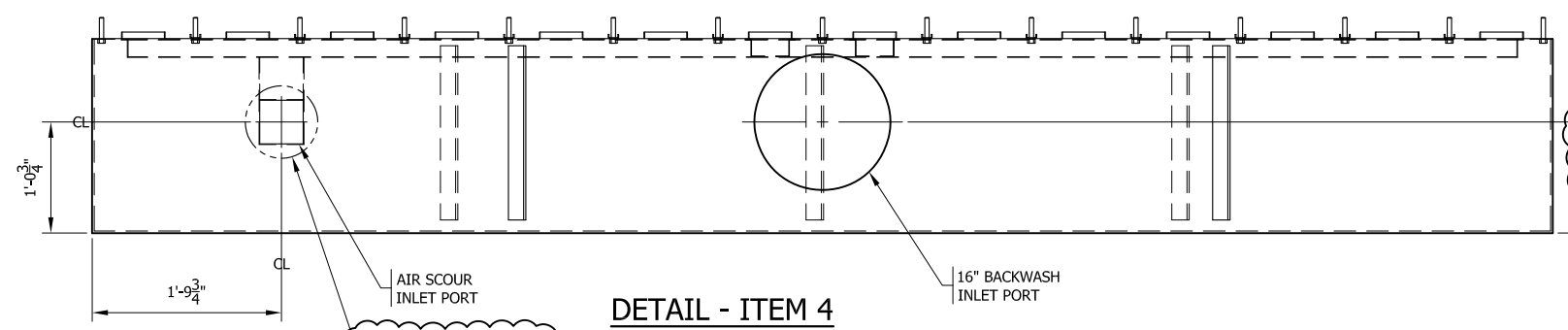
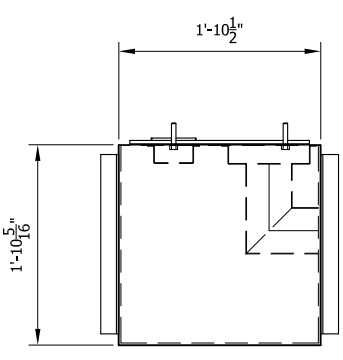
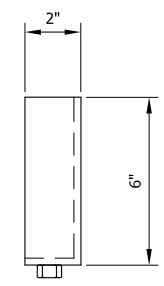
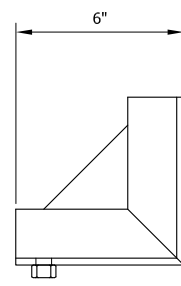

**DETAIL - ITEM 5**

**FOR APPROVAL - 03/22/2018**

SIZE D	CAGE CODE N/A	DWG NO 2346-GA-001	REV B
SCALE NONE		SHEET 6 OF 7	

**STANTEC**  
**THIS PAGE ONLY**  
**NO EXCEPTION TAKEN**

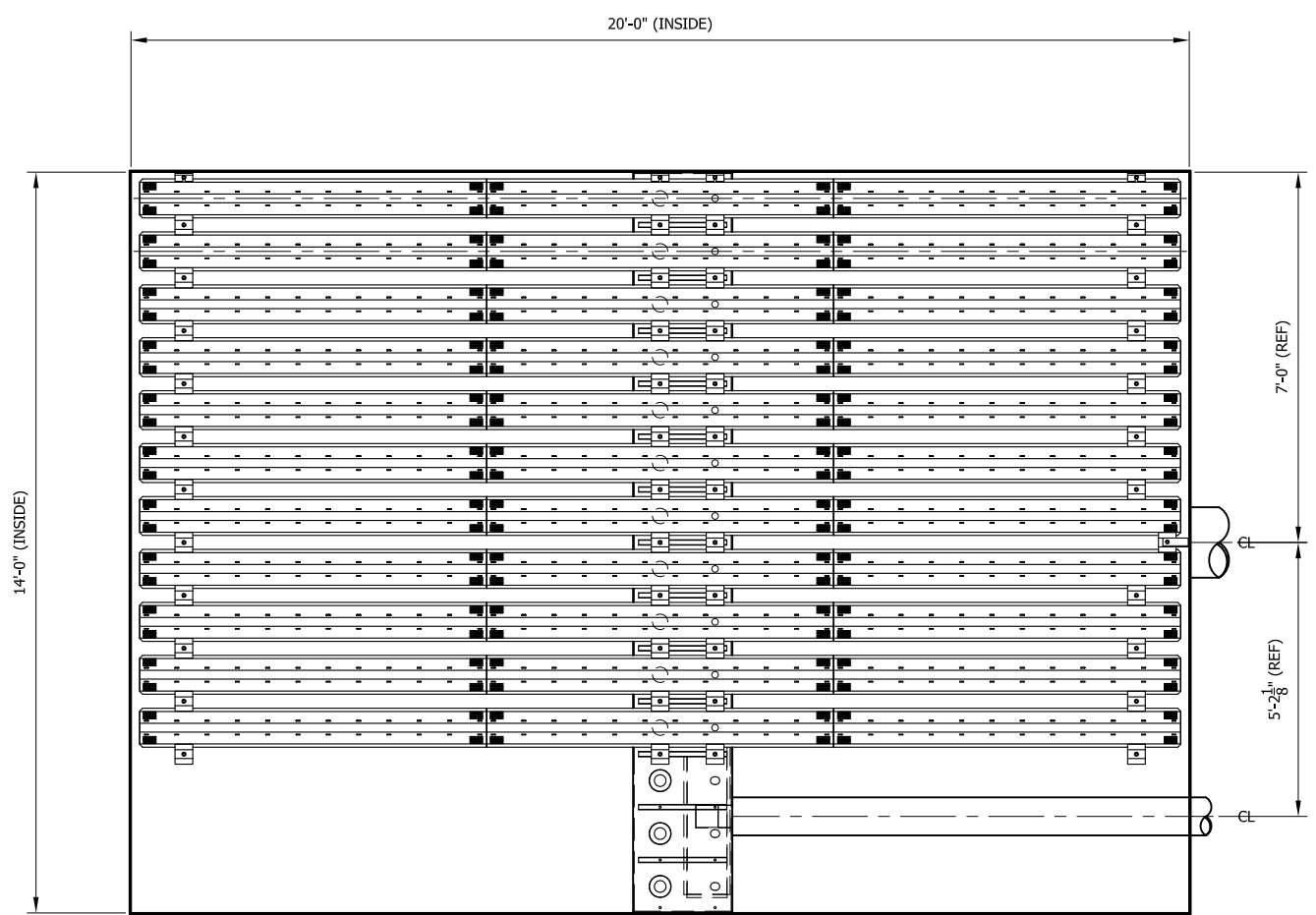

**TANK A**

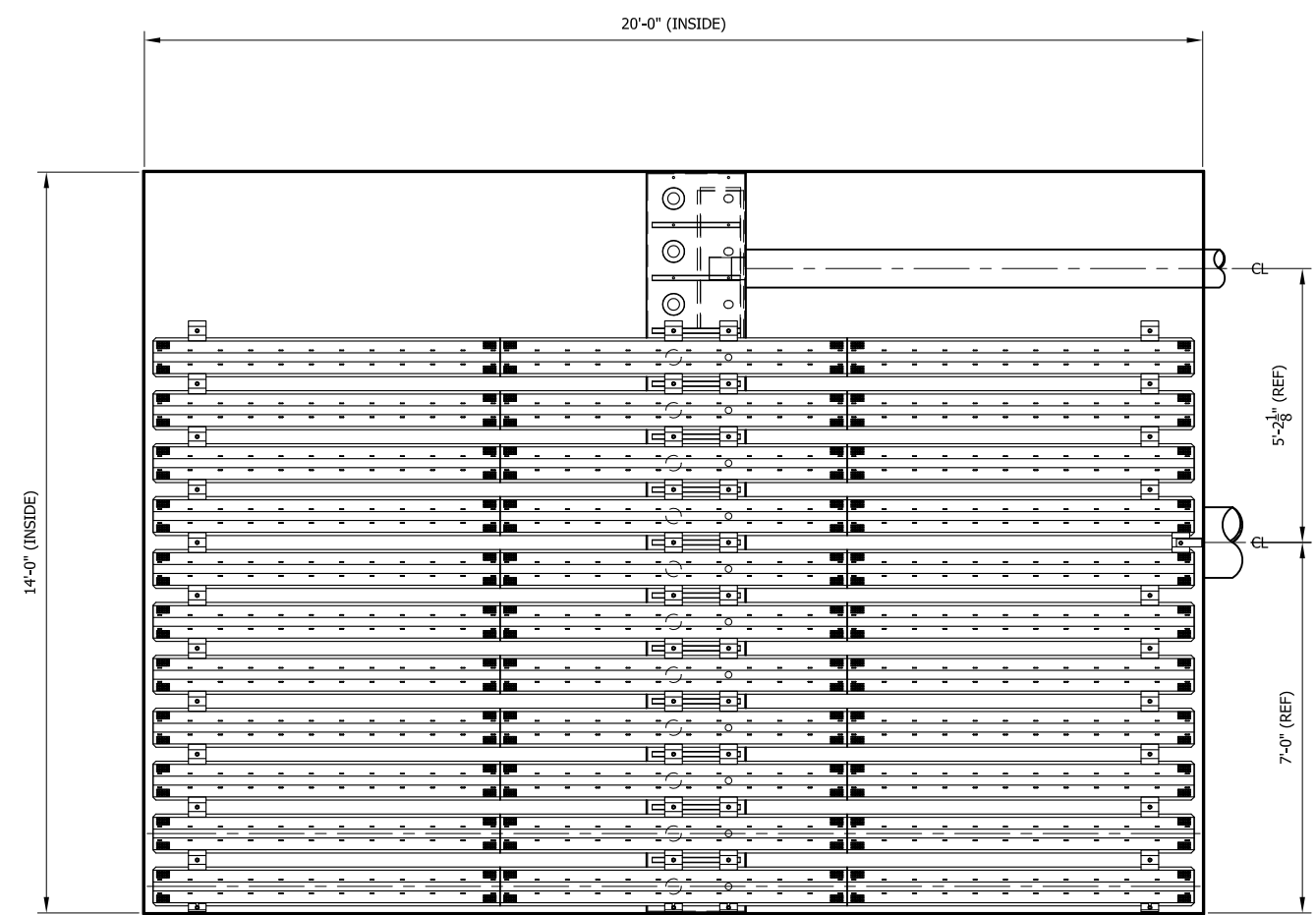

**TANK B**

- NOTES:  
1. DRAWING DOES NOT DENOTE TANK ORIENTATION IN THE FIELD.

FOR APPROVAL - 03/22/2018

SIZE D	CAGE CODE N/A	DWG NO 2346-GA-001	REV B
SCALE NONE			SHEET 7 OF 7

# **CATALOG DATA SHEETS**

**For**

**Mount Rose Water Treatment Plant  
Truckee Meadows, Nevada**

**Phoenix Underdrain System**

**As supplied by:**

**Anthratch U.S.  
471 West Universal Circle  
Sandy, Utah 84070  
(801) 566-1700**

**“For Approval”**

**March 22, 2018**

**STANTEC  
THIS PAGE ONLY  
NO EXCEPTION TAKEN**



## OFFICIAL LISTING

NSF International Certifies that the products appearing on this Listing conform to the requirements of  
NSF/ANSI Standard 61 - Drinking Water System Components - Health Effects

This is the Official Listing recorded on May 28, 2013.

**Hilti AG**  
**Feldkircherstrasse 100**  
**FL-9494**  
**Liechtenstein**  
**423 234 2111**

**Facility: Kaufering, Germany**

### Joining and Sealing Materials

Trade Designation	Size	Water Contact Temp	Water Contact Material
<b>Adhesives</b>			
Hilti HIT-CT 1 <sup>[2]</sup>	NA	CLD 23	ADH
Hilti HIT-HY 150 <sup>[2]</sup>	NA	CLD 23	ADH
Hilti HIT-HY 150 Adhesive Anchoring System [2]	NA	CLD 23	ADH
Hilti HIT-HY 150 Max <sup>[2]</sup>	NA	D. HOT	ADH
Hilti HIT-HY 150 Max Adhesive Anchoring System [2]	NA	D. HOT	ADH
Hilti HIT-HY 150 Max-SD <sup>[2]</sup>	NA	D. HOT	ADH
Hilti HIT-RE 500 <sup>[2]</sup>	NA	D. HOT	EPOXY
Hilti HIT-RE 500 Adhesive Anchoring System [2]	NA	D. HOT	EPOXY
Hilti HIT-RE 500 SD <sup>[2]</sup>	NA	D. HOT	EPOXY
Hilti HIT-RE 500 SD Adhesive Anchoring System [2]	NA	D. HOT	EPOXY
Hilti HIT-HY 150-FR <sup>[2]</sup>	NA	CLD 23	ADH
Hilti HIT-HY 150-FR Adhesive Anchoring System	NA	CLD 23	ADH
Hilti HVU Anchoring Adhesive <sup>[2]</sup>	NA	CLD 23	ADH
HIT-HY200 <sup>[1]</sup>	NA	D. HOT	ADH
HIT-HY200-A <sup>[1]</sup>	NA	D. HOT	ADH
HIT-HY200-R <sup>[1]</sup>	NA	D. HOT	ADH

[1] Certified for use as an anchoring adhesive for installing threaded rods (less than or equal to 32 mm in diameter) in concrete for water treatment applications.

[2] Product is Certified for use as an anchoring adhesive for installing threaded rods (less than or equal to 1.3 inches in diameter) in concrete for water treatment applications.

### Mechanical Devices

Trade Designation	Size	Water Contact Temp	Water Contact Material
<b>Miscellaneous Process Devices/Components</b>			
HVA Adhesive Anchoring System	3/8" - 1 1/4"	CLD 23	MLTPL

Note: Additions shall not be made to this document without prior evaluation and acceptance by NSF International.



## FDNP.MH17464 Drinking Water System Components

[Page Bottom](#)

### Drinking Water System Components

See General Information for Drinking Water System Components

**SIKA CORPORATION**

MH17464

201 POLITO AVE  
LYNDHURST, NJ 07071-3601 USA

**NSF/ANSI 61**

Plant at: Bayville, NJ

**Joining and Sealing Materials**

Trade Dsg	Water Contact Temp (°C)	Water Contact Mtl	Surface Area to Volume Ratio
SikaRepair 224 (b)	23	Cement	33 sq cm/L

Plant at: Fairless Hills, PA

**Barrier Materials**

Trade Dsg	Water Contact Temp (°C)	Water Contact Mtl	Surface Area to Volume Ratio
Plastiment (bb)	23	Cement with liquid admixture	394 cm <sup>2</sup> /Liter
Plastocrete 161 (aa)	23	Cement with liquid admixture	394 cm <sup>2</sup> / Liter
Sika AEA-14 (AEA)	23	-	394
Sika AIR (w)	23	Cement with liquid admixture	394 sq cm/liter
Sika Set NC (SSN)	23	-	394
Sika Stabilizer 4R [SS4R]	23	-	394
Sika Viscocrete 2100 (x)	23	Cement with liquid admixture	394 sq cm/liter
SikaTard 440 [ST440]	23	-	394

Plant at: Lyndhurst, NJ

**Barrier Materials**

Trade Dsg	Water Contact Temp (°C)	Water Contact Mtl	Surface Area to Volume Ratio
Sika Watertight Concrete Powder (cc)	23	Cement with Powder Admixture	394 sq cm/L

**Joining and Sealing Materials**

Trade Dsg	Water Contact Temp (°C)	Water Contact Mtl	Surface Area to Volume Ratio
-----------	-------------------------	-------------------	------------------------------

<b>STANTEC</b>			
<b>THIS PAGE ONLY</b>			
<b>NO EXCEPTION TAKEN</b>			
<b>Mortar Grout</b>			
Sikaflex 1A+ (d) (r)	23	Polyurethane	
Sealer 79 (q) (s)	23	Polyurethane	0.74 sq cm/liter
Sika Construction Sealant (q) (t)	23	Polyurethane	0.74 sq cm/liter
Sikabond Construction Adhesive (z)	23	Polyurethane	1.27 sq cm/L
Sikaflex 11FC Black (z)	23	Polyurethane	1.27 sq cm/L
Sikaflex 11FC White (z)	23	Polyurethane	1.27 sq cm/L
<b>Sikaflex 1A (q) (r)</b>	<b>23</b>	<b>Polyurethane</b>	<b>0.74 sq cm/liter</b>
Sikaflex 201 (q) (r)	23	Polyurethane	0.74 sq cm/liter
Sikaflex 221 Black (z)	23	Polyurethane	1.27 sq cm/L
Sikaflex 221 Grey (z)	23	Polyurethane	1.27 sq cm/L
Sikaflex 221 White (z)	23	Polyurethane	1.27 sq cm/L
Sikaflex 241 Black (z)	23	Polyurethane	1.27 sq cm/L
Sikaflex 241 White (z)	23	Polyurethane	1.27 sq cm/L
Sikaflex 291 Black (z)	23	Polyurethane	1.27 sq cm/L
Sikaflex 291 White (z)	23	Polyurethane	1.27 sq cm/L
SikaTop 111 Plus (1)	23	Cement	0.1 sq cm/liter
SikaTop 122 Plus (1)	23	Cement	0.1 sq cm/liter
SikaTop 123 Plus (1)	23	Cement	0.1 sq cm/liter

Plant at: Marion, OH

**Barrier Materials**

<b>Trade Dsg</b>	<b>Water Contact Temp (°C)</b>	<b>Water Contact Mtl</b>	<b>Surface Area to Volume Ratio</b>
Sika FerroGard 903 (e)	23	Cement	105 sq cm/L
Sikagard 62 (l)	23	Epoxy	36.8 sq cm/L
SikaTop 144 (n)	23	Cement	36.8 sq cm/L
SikaTop Seal 107 (f)	23	Multiple	23.2 sq cm/L

**Joining and Sealing Materials**

<b>Trade Dsg</b>	<b>Water Contact Temp (°C)</b>	<b>Water Contact Mtl</b>	<b>Surface Area to Volume Ratio</b>
Sika Flex 2C NS EZ Mix Limestone (y)	23	Polyurethane	3.0 sq cm/liter
Sika Flex 2C NS EZ Mix Tint Base (y)	23	Polyurethane	3.0 sq cm/liter
Sikadur 31, Hi-Mod Gel (NEW 1:1 Mix Ratio) (i)	23	Epoxy	17 sq cm/L
Sikadur 32 Hi Mod (a)	23	Epoxy	20.8 sq cm/L
Sikadur 35 Hi-Mod LV (g)	23	Epoxy	0.2 sq cm/L
Sikadur Anchor Fix 4 (k)	23	Epoxy	11.7 sq cm/L
Sikadur Combiflex SG System (a)	23	Multiple	25.8 sq cm/L
Sikadur Injection Gel (k)	23	Epoxy	11.7 sq cm/L
SikaRepair 224 (b)	23	Cement	33 sq cm/L

SikaTop 111 Plus (1)	23	Cement	0.1 sq cm/liter
SikaTop 122 Plus (1)	23	Cement	0.1 sq cm/liter
SikaTop 123 Plus (1)	23	Cement	0.1 sq cm/liter

STANTEC

THIS PAGE ONLY

NO EXCEPTION TAKEN

Plant at: Mesquite, TX

## Barrier Materials

Trade Dsg	Water Contact Temp (°C)	Water Contact Mtl	Surface Area to Volume Ratio
<b>cement</b>			
Plastiment ES - Summer (bb)	23	Cement	394
Plastiment ES - Winter (bb)	23	Cement	394

Plant at: Philadelphia, PA

## Joining and Sealing Materials

Trade Dsg	Water Contact Temp (°C)	Water Contact Mtl	Surface Area to Volume Ratio
SikaTop 122 Plus (1)	23	Cement	0.1 sq cm/liter
SikaTop 123 Plus (1)	23	Cement	0.1 sq cm/liter

Plant at: Santa Fe Springs, CA

## Joining and Sealing Materials

Trade Dsg	Water Contact Temp (°C)	Water Contact Mtl	Surface Area to Volume Ratio
SikaRepair 224 (b)	23	Cement	33 sq cm/L
SikaTop 111 Plus (1)	23	Cement	0.1 sq cm/liter
SikaTop 122 Plus (1)	23	Cement	0.1 sq cm/liter
SikaTop 123 Plus (1)	23	Cement	0.1 sq cm/liter

## Joining and Sealing Materials

Trade Dsg	Water Contact Temp (°C)	Water Contact Mtl	Surface Area to Volume Ratio
<b>Mortar Grout</b>			
Sikagrout 328 (c)	23	Cement	36.8 sq cm/L
SikaFix HH LV	23	-	10 sq cm/L
SikaRepair SHB mixed with water (o)	23	Cement	3.68 sq cm/L

(1) - For use as a Joining and Sealing Material at a maximum Surface Area/Volume ratio of 36.8 sq cm/L. Minimum cure time: 7 days for potable water use.

(a) - Note: Product to be applied in accordance with manufacturer`s use instructions. Epoxy - 1:1 ratio (Part A:Part B), Minimum Cure Time = 3 days, Maximum Thickness = 125 mils.

(aa) - Dosage Rate of 6 fl oz/100 lbs of cement. Maximum Surface Area per Volume Ratio = 394 sq cm/L. Order of Application = N/A. Subcomponent Mixing Ratio = N/A. Primer = N/A. Application Method = N/A. Application Thickness = N/A. Thinning = N/A. Final Cure time prior to water immersion = 36 days. Note: See Manufacturers instructions for additional product use information.

(AEA) - Up to 3 fl.oz. per 100 lbs of cement, minimum 36 day cure

(b) - Minimum Cure Time: 7 days. Product to be applied in accordance with manufacturer`s use instructions.

(bb) - Dosage rate of 4 fl oz/ 100 lbs of cement. Maximum Surface Area per Volume Ratio = 394 sq cm/L. Order of Application = N/A. Subcomponent Mixing Ratio = N/A. Primer = N/A. Application Method = N/A. Application Thickness = N/A. Thinning = N/A. Final Cure time prior to

water immersion = 36 days. Note: See Manufacturers instructions for additional product use information.

**STANTEC**

(c) - Minimum Cure Time: 3 days. Product to be applied in accordance with manufacturer`s use instructions.

**THIS PAGE ONLY**

**NO EXCEPTION TAKEN**

(cc) - Dosage Rate of 2.95 lbs/cu. yd. of cement. Maximum Surface Area per Volume Ratio = 394 sq cm/L. Order of Application = N/A.

Subcomponent Mixing Ratio = N/A. Primer = N/A. Application Method = N/A. Application Thickness = N/A. Thinning = N/A. Final Cure time prior to water immersion = 35days. Note: See Manufacturer's instructions for additional product use information.

(d) - For use as a Joining and Sealing Material at a maximum of 2% coverage on a 1000 gallon tank. Minimum cure time: 4 days for potable water use.

(e) - Maximum application rate is 1 gallon of product per 100 square feet. Maximum Surface Area per Volume Ratio = 105 sq cm/L. Order of Application = N/A. Subcomponent Mixing Ratio = N/A. Primer = N/A. Application Method = N/A. Application Thickness = N/A. Thinning = N/A. Final Cure time prior to water immersion = 36 days. Note: See Manufacturers instructions for additional product use

(f) - Maximum Use Level Corresponding to tanks greater than or equal to 4,000 gal with a maximum surface area to volume ration of 21 sq cm/liter. Order of Application/subcomponent mixing ratio = Sika TopSeal 107 consists of Sika TopSeal 107 - part A and Sika TopSeal 107 - part B mixed in a 1 to 4.1 ratio by weight. Thinning = N/A. Primer = N/A. Application Thickness (mils): 40 per coat. Number of Coats = 3. Re-coat/Cure Time prior to water immersion: 4 hours/ 7 days. Note: See Manufacturers instructions for additional product use information. This product was tested without a primer or an additional topcoat. It is recommended that any primer or topcoat used should be certified to NSF/ANSI 61 by an ANSI accredited certifier.

(g) - Note: Maximum surface area to volume ratio of 0.2 sq cm/liter, corresponding to 1% coverage of a 5,000 gal tank or 3% coverage of a 100,000 gal tank. Sikadur 35 Hi-Mod LV consists of Sikadur 35 Hi-Mod LV - part A and Sikadur 35 Hi-Mod LV - part B mixed in a 2 to 1 ratio by volume. The following use restrictions apply: Maximum Field Use Dry Film Thickness (mils): 10, Minimum Cure Temperature: 70 F, Minimum cure time: 7 days.

(i) - Note: Product to be applied in accordance with manufactures use instructions, 1:1 ratio (Part A:Part B), Minimum Cure Time = 3 days, Maximum Thickness = 125 mils

(k) - For use as a Joining and Sealing Material, only when Part A and Part B mixed in a 1:1 ratio by volume in accordance with the manufacturer's use instructions. Maximum SA/Vol: 11.9 sq cm/L

(l) - Maximum Use Level Corresponding to tanks greater than or equal to 1,000 gal with a maximum surface area per volume ratio of 37 sq cm/L. Order of Application = N/A. Subcomponent Mixing Ratio = only when Part A and Part B mixed in a 1:1 ratio by volume in accordance with the manufacturer's use instructions. Primer = N/A. Thinning = N/A. Application Thickness (mils): 10. Application Method = N/A. Final cure time/temp prior to water immersion 3 days at 73°F. Note: See Manufacturers instructions for additional product use information. This product was tested without a primer or an additional topcoat. It is recommended that any primer or topcoat used should be certified to NSF/ANSI 61 by an ANSI accredited certifier.

(n) - Maximum Use Level Corresponding to tanks greater than or equal to 1,000 gal with a maximum surface area per volume ratio of 37 sq cm/L. Order of Application = N/A. Subcomponent Mixing Ratio = only when Part A is mixed with deionized water at a ratio of 1:3 and Part A and Part B are mixed in a 9:91 ratio by weight in accordance with the manufacturer's use instructions. Primer = N/A. Thinning = N/A. Application Thickness = 32 mils. Application Method = N/A. Final cure time/temp prior to water immersion 3 days at 73°F. Note: See Manufacturers instructions for additional product use information. This product was tested without a primer or an additional topcoat. It is recommended that any primer or topcoat used should be certified to NSF/ANSI 61 by an ANSI accredited certifier.

(o) - For use as a Joining and Sealing Material, only when 50 lbs of SikaRepair SHB is mixed with 1 gal of water in accordance with the manufacturer's use instructions. Maximum SA/Vol: 3.68 sq cm/L

(q) - For use as a Joining and Sealing Material at a maximum of 2% coverage on a 1000 gallon tank. Minimum cure time: 21 days for potable water use.

(r) - Covers the following colors: black, white, colonial white, aluminum gray, capital tan, limestone and dark bronze.

(s) - Covers black color only.

(t) - Covers the following colors: white, aluminum gray, black, dark bronze, capital tan, limestone.

(w) - Dosage Rate 3 fl oz per 100 g cement. Maximum Surface Area per Volume Ratio = 394 sq cm/L. Order of Application = N/A. Subcomponent Mixing Ratio = N/A. Primer = N/A. Application Method = N/A. Application Thickness = N/A. Thinning = N/A. Final Cure time prior to water immersion = 36 days. Note: See Manufacturers instructions for additional product use information.

(x) - Dosage Rate 12 fl oz per 100 g cement. Maximum Surface Area per Volume Ratio = 394 sq cm/L. Order of Application = N/A. Subcomponent Mixing Ratio = N/A. Primer = N/A. Application Method = N/A. Application Thickness = N/A. Thinning = N/A. Final Cure time prior to water immersion = 36 days. Note: See Manufacturers instructions for additional product use information.

(y) - For use as a Joining and Sealing Material only when Part A is mixed with Part B in a ratio of 2.9 :1 by weight, in accordance with the manufacturer`s use instructions. Minimum cure time: 3 days.

(z) - For use as a Joining and Sealing Material at a maximum Surface Area/Volume ratio of 1.27 sq cm/L. Minimum cure time: 3 days for potable water use.

j - Note: Maximum surface area to volume ratio of 36.8 sq cm/liter, corresponding to tanks 1,000 gal and greater. Cure Time: 7 days.

NOTE - Manufacturer's instructions for application must be followed.

SSN - Up to 30 fl.oz. per 100 lbs of cement, Minimum 36 day cure

[SS4R] - Approved at 7 fl.oz per 100 lbs of cement

[ST440] - Approved at 15 fl.oz per 100 lbs of cement

Last Updated on 2016-05-02

**STANTEC**  
**THIS PAGE ONLY**  
**NO EXCEPTION TAKEN**

---

[Questions?](#)

[Print this page](#)

[Terms of Use](#)

[Page Top](#)

© 2016 UL LLC

The appearance of a company's name or product in this database does not in itself assure that products so identified have been manufactured under UL's Follow-Up Service. Only those products bearing the UL Mark should be considered to be Certified and covered under UL's Follow-Up Service. Always look for the Mark on the product.

UL permits the reproduction of the material contained in the Online Certification Directory subject to the following conditions: 1. The Guide Information, Assemblies, Constructions, Designs, Systems, and/or Certifications (files) must be presented in their entirety and in a non-misleading manner, without any manipulation of the data (or drawings). 2. The statement "Reprinted from the Online Certifications Directory with permission from UL" must appear adjacent to the extracted material. In addition, the reprinted material must include a copyright notice in the following format: "© 2016 UL LLC".



**STANTEC**  
**THIS PAGE ONLY**  
**NO EXCEPTION TAKEN**

# Certificate of Compliance

**Certificate:** 1521322

**Master Contract:** 224023

**Project:** 2105607

**Date Issued:** 2008/11/05

**Issued to:** AWI Filter

4450-46 Avenue SE  
Calgary, AB T2B 3N7  
Canada  
Attention: Ms. Jackie Cutter

*The products listed below are eligible to bear the CSA Mark shown*



Drinking Water  
NSF/ANSI 61

**Issued by:** Grazyna Blazejewska

**Authorized by:** Nick Alfano, Operations  
Manager

## **PRODUCTS**

**CLASS 6861 06** - JOINING & SEALING MATERIALS - NSF/ANSI 61 SECTION 6 -  
Certified to NSF/ANSI 61

Gasket Material

- Compression Gasket Material [1]
- [1] Water contact surface area/volume ratio is not to exceed 6.5 cm<sup>2</sup>/ Liter.

## **APPLICABLE REQUIREMENTS**

NSF/ANSI 61 – 2007a - Drinking Water System Components – Health Effects



## **POLYMER INDUSTRIES Certificate of Conformance**

5/29/2017

To whom it may concern,

This letter is to certify that our Densetec Pipe grade sheet meets the requirements of the following ASTM tests

ASTM D4801:

- type III (weather-resistant black)

ASTM D1248:

- Class C ( not less than 2% carbon weather-resistant)
- W8/W9 ( 2 to 3% carbon, LP390 type III, class H, grade 2)

Chemical Compliance:

- We do not use materials that contain lead nor do we add it during our manufacturing process.
- We can state that our Pipe Grade materials contain less than 250 ppm of Lead, Sulfur and chlorine

NSF 14/61 Compliance

- Our pipe grade resin is NSF 14/61 certified by our resin supplier for use in Potable water applications.

If you require any further assistance please feel free to contact me at the number below.

**Robert Skuce**

Operations Manager

Polymer Industries

256-657-5197

[Robert.skuce@polymerindustries.com](mailto:Robert.skuce@polymerindustries.com)

**STANTEC  
THIS PAGE ONLY  
NO EXCEPTION TAKEN**

**P.O. Box 32 Highway 40 Henagar. Alabama 35978 phone (256) 657-5197 Fax (256) 657-5198**

## Section Seven: Electrical Controls

---

This Page Intentionally Blank

## Integrated Controls Submittal

Controls for this project are produced by Integrated Controls, Inc.

This Page Intentionally Blank

**STANTEC**  
**THIS PAGE ONLY**  
**NO EXCEPTION TAKEN**

SUBMITTAL  
Do Not Use  
For Installation

**TMWA Mt. Rose, NV**  
**Trident System Controls**  
ICI Job# 03694-01-00

Submittal No. 2  
July 19, 2018

SUPPLIED BY:

**WesTech, Inc.**  
600 Arrasmith Trail  
Ames, IA 50010  
(515) 268-8464

**INTEGRATED CONTROLS, INC.**  
15707 South Mahaffie Street  
OLATHE, KS 66062  
(913) 782-9600

**STANTEC**  
**THIS PAGE ONLY**  
**NO EXCEPTION TAKEN**

SUBMITTAL  
Do Not Use  
For Installation

This Page was left blank intentionally.

# CONTENTS

- SECTION 1 Description of Operation**
- SECTION 2 Master CP Drawings**
- SECTION 3 Slave CP 1 Drawings**
- SECTION 4 Slave CP 1 Drawings**
- SECTION 5 Bill of Materials**
- SECTION 6 Cut-Sheets**

**STANTEC**  
**THIS PAGE ONLY**  
**NO EXCEPTION TAKEN**

SUBMITTAL  
Do Not Use  
For Installation

This Page was left blank intentionally.

**STANTEC**  
**THIS PAGE ONLY**  
**NO EXCEPTION TAKEN**

SUBMITTAL  
Do Not Use  
For Installation

# SECTION 1

**Description of Operation**

**STANTEC**  
**THIS PAGE ONLY**  
**NO EXCEPTION TAKEN**

SUBMITTAL  
Do Not Use  
For Installation

This Page was left blank intentionally.

## Description of Operation

### General Information

The description below is intended to provide the owner with an understanding of the operation of a WesTech Engineering, Inc. Trident HS water treatment system. A Trident HS System consists of two parallel units. References in this document to unit are referring to one of the two. Many of the operating parameters are dependent on the actual incoming water and the owner's system requirements. The actual operating parameter details such as chemical feed settings, recirculation rates and sludge blow down interval and duration will be determined during startup.

*Reference the WesTech Engineering, Inc. Process Flow Diagram while reading the descriptions below. The descriptions include assigned tag references. For this two tank system replace the "X" in each tag with a "1" for unit 1; replace the "X" with a "2" for unit 2 ie. Tag (FIT-2X14) becomes (FIT-2114) for unit 1 and (FIT-2214) for unit 2 etc.*

### Standard Trident HS System Operational Description

#### Raw Water Chemical Addition

The first step of the process is chemical addition. Coagulant dosage can be controlled manually, by chemical dosage set point, or by process feedback set point with the integrated Aquaritrol<sup>®</sup> process control logic. Following chemical addition, recycled process sludge is added and mixed via an in-line static mixer. With proper chemical/coagulant dosing, colloid destabilization of the raw water occurs rapidly, causing chemical floc (Agglomerated particles) to form, the rate of destabilization / precipitation is also enhanced by the intermixing of the recycled sludge from the Tube Clarifier. Prior to entering the Tube Section, an Anionic polymer flocculent aid is added to strengthen the newly formed floc into larger, more solid particles which aids settling in the tubes. All chemical feeds are injected whenever the system has forward flow.

#### Influent Turbidity Monitor (OPTIONAL)

The optional Influent Turbidity Monitor may be utilized to assist with the control of the coagulant feed system. The system PLC shall receive a 4-20 mA signal from the turbidity monitor and can be setup to adjust the coagulant dosage if a significant turbidity event is detected. The controls include an adjustable time lag that will allow the current turbidity value to be stored for comparison at the expiration of the next

**STANTEC**  
**THIS PAGE ONLY**  
**NO EXCEPTION TAKEN**

cycle. If a change greater than 10 percent is detected and the control is enabled, a preemptive adjustment will be made to the coagulant control output step. The size of the change should be determined through operation and testing at each facility. The set point for percentage of deviation from the last sample, and the step change to the coagulant feed rate will be manually adjustable by the plant operator by means of a Human Machine Interface (HMI).

### **Influent Streaming Current Monitor (OPTIONAL)**

The optional Streaming Current Monitor may be utilized in lieu of using the effluent turbidity to control the coagulant feed system. The system PLC receives a 4-20 mA signal from the Influent Streaming Current Monitor. The influent streaming current is used to control the coagulant feed system when selected and shall adjust the coagulant dosage to maintain the proper streaming current set point. The controls shall also include an adjustable time lag from the point of chemical addition to the point of streaming current measurement to assure that the system is responding accurately to current treatment conditions before another change is initiated. The set point shall be manually adjustable by the plant operator by means of the HMI.

### **Influent pH Monitor (OPTIONAL)**

The optional pH Monitor may be utilized to control the caustic feed system. The system PLC receives a 4-20 mA signal from the Influent pH Monitor. The influent pH is used to assist the setup of the caustic feed system and shall adjust the caustic dosage to maintain the proper pH set point. The controls shall also include an adjustable time lag from the point of chemical addition to the point of acid measurement to assure that the system is responding accurately to current treatment conditions before another change is initiated. The set point shall be manually adjustable by the plant operator by means of the HMI.

Switch or pushbutton controls mentioned below are graphic representations on the HMI screens not actual physical switches and push buttons.

### **Tube Clarifier – General Description**

The Tube Clarifier influent is regulated by a flow control valve (MOV-2X04). The flow control valve modulates to maintain the flow into the Tube Clarifier based on feedback from the influent flow transmitter (FIT-2X04). This set point is operator adjustable through the HMI. The acceptable range is 50 – 100% of design flow.

The chemically treated influent water enters the tube section and mixes with previously formed solids forming a “sludge blanket”. This sludge blanket provides a large surface area for particle interaction, floc growth

and densification. Lamella tubes, installed diagonally in the upper sludge basin provide a large projected surface area on which the floc can settle. The sludge blanket depth should be maintained up into approximately twenty – thirty percent of the lamella tubes. The sludge blanket depth is controlled via operator adjustable automatic blow down time cycles. This level is estimated based on influent quality, chemical addition, and sludge concentration during a blow down cycle. An increase in any of these may require the set point for blowdown interval to be shortened, while a decrease in these will allow for longer interval set points. During the blow down cycle, the sludge recycle is diverted to waste lowering the blanket in the basin. The operator will have adjustable blow down interval time to control this process through the HMI.

During normal recycle operation a portion of the sludge is continuously drawn from the bottom of the basin through the sludge header of the tube clarifier through a sludge recycle/blowdown pump (HS-2X05). The sludge is pumped back to the system feed ahead of the static mixer. This recirculation aids the floc formation. The sludge flow (FIT-2X05) is measured and controlled by a PID loop which operates the sludge recycle/blowdown pump. The flow is controlled using a sludge recycle or sludge blowdown set point from the PLC. These set points are operator adjustable through the HMI.

A reduction of influent solids up to eighty percent is possible across the Tube Clarifier section.

The operating modes for the Trident HS sludge sucker are Manual-Auto. Each mode of operation is described in more detail below.

### **Tube Clarifier Operation Description - Automatic**

- The sludge removal header can be selected to either continuously travels back and forth across the floor of the tube clarifier section, or stay at the park end of the basin during normal recycle operation. If set to continuous, when the unit starts up, the header will start at the park end and travel forward until the forward end proximity switch (ZSE-2X16) is made. At this point, the PLC will reverse the sludge sucker drive and the header will reverse direction and return to the park end. When the header reaches the park end proximity switch (ZSS-2X16) the header will reverse and the cycle will repeat. If set to non-continuous the header will remain at the park end of the basin during normal recycle operation and only sweep during the sludge blowdown operation.
- Sludge recirculation flow is continuous and is adjustable via an operator adjustable set point entered as a percent of Trident HS unit forward flow, typically around 10%. The sludge recirculation valve (SV-X05) is open allowing the recirculation to return to the raw water feed line as described above. The VFD driven sludge recycle pump

(HS-X05) speed varies to maintain the operator adjustable recirculation flow set point.

- A sludge blowdown step is used to maintain the level of the sludge blanket in the tube clarifier. An Operator adjustable sludge blowdown interval timer runs when the tube clarifier is in operation. When the interval timer times out, the sludge blow-down valve (SV-205) will open when the basin reaches one or the other end of the basin and the sludge will then be pumped to waste by the recycle pump. The blowdown will continue until the header reaches either the opposite end of the basin or until the header returns to the original start end of the basin as selected by the Operator through the OIT. (Single sweep blowdown or two way sweep blowdown.) The blowdown rate set point for the recycle pump VFD speed control PID loop will initially be set at the recycle rate but will be adjustable through the HMI.

### **Tube Clarifier Operation Description - Manual**

- In Manual mode the sludge removal header will move back and forth across the basin as described above but the operator must select a “Stop Header” or Start Header” pushbutton on the HMI.
- The sludge recirculation and sludge blow down valves can also be opened and closed manually through the HMI by the operator selecting the Recirculation valve “Open” or “Close” or the Sludge Blow-down valve “Open” or “Close” pushbuttons on the HMI.
- The operation of the recirculation pump will be done manually using a Hand/Off/Auto selector on the HMI or locally at the VFD. The speed of the drive will be adjustable at the HMI with a manual speed set point, or locally at the VFD.
- The operation of the sludge removal header, recirculation pump, and the valves is completely manual. The operator should have a complete understanding of the system operation before employing this feature. The proper formation and maintenance of the sludge blanket is critical to effective system operation.

### **Tube Clarifier - Sludge Sucker - Features, Alarms and Interlocks**

- The sludge header controls are interlocked so that only one direction at a time may be selected, either manually or automatically.
- The sludge removal header will move across the basin in one direction at one pre-selected speed established at startup, typically set at approximately four feet per minute. The speed is set utilizing a

potentiometer adjustment on the DC drive speed board. One speed can be set for forward direction and one for the reverse direction. Both will typically be the same.

- The position of the sludge removal header can be monitored by the indicators on the HMI. Park End, Forward End and Traveling indicators are included. A rotational switch (ZSR-X16) is mounted on the main sludge sucker header drive shaft. It has a rotational encoder that activates the drive rotation proximity switch 4 times per revolution. The PLC counts the revolutions of the main drive pulley. The PLC switch counter increments while the sludge header is moving. If the drive is initiated in either direction and the proximity switch does not register a count for a preset time delay (adjusted at start-up) or if the counter continues to count but neither the start or end proximity switches are made for a preset time (adjusted at startup) the PLC shall interpret the unit is slipping or malfunctioning. The header drive will be stopped and a high torque alarm will be indicated on the HMI and the alarm horn sounded. This count is also used to indicate the approximate position of the header on the HMI as the counts increase and decrease while the unit is traveling. The high torque alarm must be reset at the HMI before the system can be restarted.
- If the torque overload light illuminates the unit will stop. Upon depressing the reset button the unit will restart and continue in the same direction. The alarm feature for the torque overload is active in both the "Auto" and "Manual" modes.
- The sludge recycle system includes a VFD to control the sludge recycle/sludge blowdown pump (HS-X05). The Main Control Panel PLC will receive an analog flow signal from the sludge recycle/sludge blowdown flow meter (FIT-2X05). The VFD will receive a start command and a speed signal from the PLC. The PLC will use the flow set point and analog input signal to control the sludge recycle flow using a PID loop controller internal to the PLC. The sludge pump VFD will interface all pertinent operational and control data and VFD faults with the PLC .
- The VFD will have a Hand /Off/ Auto selector switch on the HMI for manual operation if required. The manual operation will include an operator adjustable speed output selection.

### **Adsorption Clarifier – General Description**

The Tube Clarifier supernatant enters an effluent header and a transfer pump (HS-X10) pumps the solution into the Adsorption Clarifier (AC) section. The transfer pump is controlled by a VFD (VFD-2X10) and the VFD speed is regulated to maintain a consistent level (LIT-2X10) in the Tube Clarifier using a PID loop controller in the control panel PLC, a tube clarifier level set point and the analog signal from the Level transmitter

**STANTEC**  
**THIS PAGE ONLY**  
**NO EXCEPTION TAKEN**

(LIT-X10). Prior to entering the AC, a Cationic polymer flocculent aid is typically added to again strengthen the floc and promote solids capture.

The Trident HS adsorption media has a specific gravity less than water. Before flow begins, the media floats and naturally rests against the bottom of a retaining screen near the top of the AC chamber. As the water flows upward through the AC media the retaining screen holds the media in place.

During service the media bed offers resistance to the upward flow of the water. For water temperatures between 0 and 20 degrees Celsius, this resistance, or "clean bed headloss," is typically less than 18 inches of water column (0.65 psi) across the media bed when operating at the typical rate of fifteen gallons per minute per square foot of clarifier bed area.

During operation, solids are removed by the clarifier media. As the solids accumulate they cause the head loss across the clarifier to increase. This is detected by a pressure gauge (PI-X10) and switch assembly (PSH-2X10) measuring the pressure in the area beneath the media. When the pressure increase reaches a preset level (2.6 psi), the switch closes and a flush or cleaning cycle is initiated. There is a second pressure switch (PSHH-2X10) set at a higher level (3.0 psi) which, if actuated, will shut down the Trident HS unit. This is a precaution against damage to the tankage and/or media retaining assembly.

Besides high head loss, a flush cycle can also be initiated by an adjustable interval timer in the PLC, or by a "Flush Start" pushbutton on the HMI.

When a flush cycle is initiated, the influent valve (FCV-X04) closes and the waste valve (SV-X07) opens, causing the water in the trough to flow to waste. The filter effluent valve will close as the filter level drops below normal. An air blower (B006-A or B006-B) is started. After the blower pressure switch (PSH-006) activates indicating adequate air pressure (3.5 psi) the AC air inlet valve (SV-X11) opens. Air is distributed to the bottom of the adsorption clarifier. This causes downward expansion and fluidization of the adsorption media; excess solids are scoured, forming slurry. After a brief period, controlled by a timer in the PLC program, the influent valve (FCV-X04) reopens and the flushing begins with a flow rate of 10 GPM/square foot (930 GPM) water combined with the air from the blower. The water level in the AC rises until it flows over the lip of the waste trough. The clarifier compartment water flushes to waste through the wash trough and the previously opened waste valve (SV-X07).

During the flush cycle the influent flow set point to the influent flow control valve (FCV-X04) is kept at its current setting and the difference between its flow and the required flow of 930 GPM (10 GPM/FT<sup>2</sup>) is made up by the flush supply valve (FCV-234X) as confirmed through the flush supplement mag flow meter (FIT-2371). This flush rate is

established to ensure the correct cleaning action of the media.

The flush cycle continues for a preset duration (typically 3-5 minutes), then the influent and supplement flow and is stopped. The air continues on for another 30 to 45 seconds to re-level the media bed and dissipate any flow currents induced by the flush cycle. The air is then also stopped, allowing a short period of no flow or air to permit the media to return to its normal depth against the retainer panels.

After the bed settle period (generally only 30 to 40 seconds) the influent and flush flow is restarted at their flow set points. The waste valve is still open so the clarifier effluent flows to waste rinsing the clarifier media. The clarifier effluent water is not totally clear at the end of this time. This is normal and desirable. The solids left within the media are beneficial to the contact flocculation that takes place in the media. This flush will remove the majority of the solids in the clarifier and will restore the bed to a near clean-bed headloss condition.

The AC rinse to waste flows for about 5 minutes, then the waste valve is closed and the flush supplement valve is closed. The flow to the filter is re-established and the effluent valve reopens as the filter level returns to the normal level.

The AC flush cycle can be expected to take place more often than a filter backwash. It is normal to have two to four AC flushes during a single filter service cycle.

The AC unit is controlled by three modes of operation Automatic /Semi-Automatic/ Manual. Each operating mode is described in more detail below.

### **Adsorption Clarifier – Automatic**

- The AC flush cycle is initiated automatically by a pre-set high headloss switch (PSH-2X10) or an operator adjustable interval timer. When the high pressure switch closure is detected or the timer is complete, the PLC automatically cycles the AC through the flush sequence described above and returns the AC and Trident HS system to service without any operator input.

### **Adsorption Clarifier – Semi-Automatic**

Call for an AC flush cycle is initiated automatically by a pre-set high headloss switch (PSH-2X10) or an operator adjustable service timer. When the switch is detected or the timer is complete, the PLC sounds an alarm indicating the need for a flush cycle. The system continues to run in service until the operator actuates the AC semi-automatic “Start Flush” pushbutton on the HMI. The PLC will then stop the system and automatically cycle the AC through the flush sequence described above

and return the AC and system to service without any further operator input.

The flush can be performed at any time by placing the AC in the Semi-Auto mode on the HMI and actuating the “Start Flush” pushbutton.

### **Adsorption Clarifier – Manual**

While in Manual mode the operator can open and close the AC valves and operate the air blower through the HMI by selecting: Clarifier “Influent Valve Open” (MOV-2X10); “Influent Valve Close”; “Waste Valve Open” (MOV-2X07); “Waste Valve Close”; Clarifier “Air Inlet Valve Open” (MOV-2X11); “Air Inlet Valve Close”. The air blower (BL-2110 or BL-2120) can be called to run by placing the Hand /Off/ Auto selector on the HMI to the Hand position. The air blowers should be alternated in service.

### **Adsorption Clarifier – Features, Alarms and Interlocks**

- The Adsorption Clarifier includes a VFD to control the transfer pump (P-2X10). The Main Control Panel PLC will receive an analog level signal from the tube clarifier level sensor (LIT-2X10). The VFD will receive a start command and a speed signal from the PLC. The PLC will use the level set point and analog input signal to control the transfer pump speed using a PID loop controller internal to the PLC. This will maintain the flow out of the tube clarifier at the same flow as into the unit.
- The transfer pump VFD will interface all pertinent operational and control data such as process variable, set point and VFD faults with the PLC.
- The VFD will have a Hand /Off/ Auto selector switch on the HMI for manual operation if required. The manual operation will include an operator adjustable speed output selection.
- The AC influent is monitored for turbidity level (AIT-2X10). This turbidity reading is transmitted to the PLC and includes two operator adjustable setpoints. The high turbidity will alarm only. The second High-High Turbidity alarm will place the system Offline.

### **Mixed Media Filter – General Description**

WesTech Engineering, Inc. mixed media filter bed approaches the ideal filter design. The filter’s unique combination of material sizes result in a bed that hydraulically grades coarse to fine in the direction of filtration. This allows true depth filtration and the associated benefits of high solids storage, high rates and high quality effluent.

**STANTEC**  
**THIS PAGE ONLY**  
**NO EXCEPTION TAKEN**

Three materials are used: anthracite coal, silica sand and special high-density sand. The careful size and density ratio provides a filter bed that maintains a stable relationship between the grains during an indefinite period of use and backwash cycles. The coarse, low-density grains remain at the top of the bed and the finely sized high-density grains at the bottom. There is no distinct layer effect but a gradual decrease in average grain size from the top of the filter to the bottom.

The large grains at the top of the filter allow a great number of particles to be held before the cleaning cycle called a backwash are required. The fine sand (0.2 mm) at the bottom of the filter provides a large surface area that is very effective in achieving high quality effluent. Only a small amount of this fine material is needed to provide efficient filtration resistance to flow surges and improved bed stability.

The filter bed is supported by the MULTIBLOCK<sup>®</sup> underdrain system. The filtered water is uniformly collected by the underdrain and flows to the clearwell.

After a period of time, sufficient solids will be trapped in the filter to increase the pressure difference across the media called headloss to the terminal headloss set point at which time a cleaning cycle is required. Water is pumped into the underdrain system reversing the flow through the media to drain removing much of the trapped solids. This cleaning process is called backwashing. The need for backwash is indicated by a headloss gauge (PI-2X01) and is initiated by a vacuum switch (PSL-2X01). The influent flow to the Trident HS unit is stopped to perform the filter backwash.

The first step of the backwash cycle is the simultaneous air and low-rate water flow backwash. The effluent valve (MOV-2X01) is closed and the waste valve (MOV-2X07) is opened. The air / water backwash step begins with starting both air blowers (BL-2110 and BL-2120). If the blower pressure is acceptable as indicated by the blower pressure switch (PSH-276X), then the filter air valve (MOV-2X12) is allowed to open. After a short pre-determined time delay to allow the air blower to start the filter air valve will open.

Note: During backwash, the influent flow to the other treatment unit is maintained, providing uninterrupted water production.

At the same time the air is being applied to the filter, the PLC calls for a backwash pump (P-24X0). After calling the pump, there is a short time delay to allow trapped air to be forced from the backwash supply line. The backwash supply valve (MOV-2X02) slowly opens to the low flow rate set point allowing the clean backwash water from the clearwell or backwash storage tank to flow into the underdrain up through the media and out the waste valve (MOV-2X07). The low-rate flow is typically at a rate of 5 GPM/ Ft<sup>2</sup> (1400 gpm) as confirmed by the backwash flow meter (FIT-2470). This flow rate must be adjusted correctly to prevent media loss.

The combination of air and low-rate backwash water quickly breaks up the top of the filter media and allows the bed to become fluidized and

**STANTEC**  
**THIS PAGE ONLY**  
**NO EXCEPTION TAKEN**

fully expanded early in the backwash period. It provides the auxiliary agitation required to effectively "scrub" and clean the media particles.

The simultaneous air and low-rate water flow is continued for an operator adjustable time. When the simultaneous air and low-rate water step is complete the air blowers are turned off. The low-rate water flow is maintained for a short pre-set period of time to allow the entrapped air to purge from the filter media before beginning the high-rate water only backwash step.

When the air purge step is complete the backwash supply valve (MOV-2X02) is opened to the high rate set point and the high-rate backwash step begins. The high flow rate is typically set at 15 GPM/Ft<sup>2</sup> (4200 GPM). This backwash rate is based on 60°F water temperature. The required high rate varies depending upon the actual water temperature as shown on the chart provided in the Operations Manual. The correct backwash high-rate flow is based on plant conditions and water temperature. This flow also must be set correctly to prevent media loss.

During high-rate backwash, the Mixed Media fluidizes and expands by approximately 20-30 percent.

When the high-rate backwash step is completed, the backwash supply valve (MOV-2X02) is closed. After allowing time for the valves to slowly close the backwash pump is stopped and the waste valve (MOV-2X07) is closed.

After the backwash steps are completed the Trident HS unit will be placed back into a forward flow and the effluent water diverted to drain through the filter to waste valve (MOV-2X15). This filter to waste step allows the system to again stabilize in a forward flow before the water is directed to service.

The filter to waste minimum step continues for a pre-determined amount of time, typically 5-10 minutes.

The filter to waste step continues until the minimum filter to waste timer expires and the unit's filtered water turbidimeter reached an operator adjustable set point, typically 0.3 NTU. At this time, a short duration timer is started to confirm that the turbidity value is stable, and then the cycle is ended. When filter to waste is complete, the filter to waste valve closes and the service effluent valve opens and the filter resumes filtering. If the process does not yield acceptable water within the pre-determined time period, typically 20-30 minutes, the cycle will end when a filter to waste maximum timer reaches its set point. An alarm will sound and the unit will be removed from service based on a high turbidity at backwash completion.

The Media Filter is controlled by three modes of operation, Automatic, Semi-Automatic and Manual. Each operating mode is described in more detail below.

### **Mixed Media Filter – Automatic**

The filter backwash cycle is initiated automatically by any of three methods; a preset duration for hours of operation, a pre-set high headloss vacuum switch (PSL-X01), or a pre-set high turbidity level (typically > 0.3 NTU). When one of these is true, the PLC stops the Trident® HS unit and automatically cycles the filter through the backwash sequence described above and returns the unit to service without any operator input.

### **Mixed Media Filter – Semi-Automatic**

The filter backwash required alarm is set by any of three methods. A preset duration for hours of operation, a pre-set high headloss vacuum switch (PSL-2X01), or or a pre-set high turbidity level (typically > 0.3 NTU). When one of these is true, the PLC sounds an alarm indicating the need for a backwash cycle. The system continues to run in Service until the operator selects the filter semi-automatic “Start backwash” pushbutton on the HMI. The PLC will then stop the Trident HS unit, automatically cycle the filter through the backwash sequence described above and return the unit to service without any further operator input.

The backwash cycle can be performed any time by placing the filter into Semi-Auto mode and selecting the “Start Backwash” pushbutton.

### **Mixed Media Filter – Manual**

While in Manual mode the operator can open and close the filter valves and start and stop the backwash supply and air blowers through the HMI by selecting: filter “Effluent Valve Open” (LCV-X15); “Effluent Valve Close”; Filter “Air Inlet Valve Open” (SV-X12); “Filter Air Inlet Valve Close”; “Backwash Supply valve Open” (SV-X102); “Backwash Supply Valve Close” “Backwash High-Rate Valve Open” (SV-010); “Backwash High Rate Valve Close” “Filter to Waste Valve Open” (LCV-X15) or “Filter to Waste Valve Close” pushbuttons on the HMI. The backwash supply and the air blowers can be called to run by placing the Hand /Off/ Auto selectors on the HMI to the Hand position.

### **Mixed Media Filter - Features, Alarms and Interlocks**

- The Trident® HS unit will be interlocked to prevent more than one filter from backwashing at a time.
- Media Filter Low level alarm – closes effluent valve
- Media Filter High level alarm – unit shut down

**STANTEC**  
**THIS PAGE ONLY**  
**NO EXCEPTION TAKEN**

- Media Filter High Headloss alarm – initiates backwash
- Media Filter Effluent High pressure alarm – unit shut down
- Filtered water turbidity exceeds an adjustable setpoint, typically set at >0.3 NTU. The unit will shut down and a backwash will commence, if set on Automatic or will generate an alarm if set in Semi-Auto. If this condition is still present after the backwash and filter to waste cycles, the unit will shut down and an alarm will be activated.

### **Common System Component - Features, Alarms and Interlocks**

Components connected via PROFIBUS DP or Ethernet/IP network:

- Master Control Panel PLC
- Each Slave Unit control panel

The Adsorption Clarifier and Mixed Media Filter are interlocked so the AC flush and the filter backwash cycles cannot be performed at the same time.

Systems with more than one Trident HS unit are interlocked so that no AC flush or backwash cycle occurs at the same time.

### **Common System Alarms - plant shut down**

- System Feed Flow – minimum flow enables the Trident® HS unit to run
- Emergency Stop pushbutton
- Tube Clarifier High-High Level alarm
- Inter-Clarifier Turbidimeter High-High Level alarm
- Adsorption Clarifier High-High Pressure alarm
- Media Filter High level alarm
- Media Filter Effluent High pressure alarm
- Trident HS unit Effluent High-High Turbidity alarm
- Both Lead and Standby Blower Fails on Clarifier Flush

### **Common System Alarms - alarm only**

- Low Level Clearwell during backwash – prevents or stops a backwash
- Sludge Pump VFD alarm
- Clarifier Transfer Pump VFD alarm
- Inter-Clarifier Turbidimeter High Level alarm
- Trident call to run sludge pump HOA in Off position
- Trident call to run transfer pump HOA in Off position
- Blower fail – alarm and start alternate blower
- Both blowers fail on filter backwash– alarm and continue backwash without air

**Operational Sequence Table**

	Manual - Per operator selection	Trident® HS in Service	Sludge Blow Down	AC Flush					Filter Backwash			
				Fluidize Bed - Expansion with Air	Flush Bed with Water and Air	Bed Re-leveling with Air	Bed Settle	Rinse AC to Waste	Low Rate Water with Air	Air Purge	High Rate Water Only	Rinse Filter to Waste
System Cycles are Bold /Mode Steps are not bold												
<b>Common Equipment</b>												
Common Influent valve MOV-2X04		O	O	X	O	X	X	O	X	X	X	O
Waste Discharge Valve MOV-2X07		X	X	O	O	O	O	O	O	O	O	X
Backwash Pump 1 P-2410		X	X	X	X	X	X	X	O*	O*	O*	X
Backwash Pump 1 P-2420		X	X	X	X	X	X	X	O*	O*	O*	X
Air Blower 1 BL-2110		X	X	O*	O*	O*	X	X	O	X	X	X
Air Blower 2 BL-2120		X	X	O*	O*	O*	X	X	O	X	X	X
Sludge Recirculation Valve MOV-105**		O	X	X	O	X	X	O	X	X	X	O
Sludge Blow Down Valve MOV-205**		T	O	X	T	X	X	T	X	X	X	T
<b>Tube Clarifier Section</b>												
Sludge Sucker Drive Forward - to Limit ZSE-2X16		O	O	X	O	X	X	O	X	X	X	O
Sludge Sucker Drive Reverse - to Limit ZSS-2X16		O	O	X	O	X	X	O	X	X	X	O
Sludge Recycle Pump P-2X05		O	O	X	O	X	X	O	X	X	X	O
<b>Adsorption Clarifier Section</b>												
Clarifier Transfer Pump P-2X10		O	O	X	X	X	X	O	X	X	X	O
Clarifier Influent Valve MOV-2X10		O	O	X	X	X	X	O	X	X	X	O
Clarifier Air Inlet Valve MOV-2X11		X	X	OA	OA	OA	X	X	X	X	X	X
Flush Makeup Valve, MOV-234X												
<b>Filter Section</b>												
Filter Effluent valve MOV-2X01		O	O	X	X	X	X	X	X	X	X	X
Effluent Turbidity Sample Pump HS-2X01		O	O	X	X	X	X	X	X	X	X	O
Effluent Turbidity Sample Valve SV-2X02		O	O	X	X	X	X	X	X	X	X	O
Filter Air Inlet Valve MOV-2X12		X	X	X	X	X	X	X	OA	X	X	X
Backwash Inlet Valve MOV-2X02		X	X	X	X	X	X	X	O	O	O	X
Filter To Waste Level Control Valve LCV-X15		X	X	X	X	X	X	X	X	X	X	O

**Table 1-1 – Operational Sequence Table**

**TABLE LEGEND**

O = Open / On

X = Closed / Off

O\* = Alternate blowers and backwash pumps after each Filter Backwash cycle.

A = If blower Pressure is OK

T = Operates based on PLC timer

\*\*The common sludge recycle valve will open whenever one unit is in normal recycle operation. It will close during blowdown. If there is only one unit on-line and it goes into a flush or backwash then the valve will operate as shown in table.

### Typical operating system timer ranges:

#### Tube Clarifier Step Time Ranges:

Sludge Blowdown Interval	0-24 Hours (1440 minutes factory pre-set)
--------------------------	--

#### Adsorption Clarifier Step Time Ranges:

Bed Expansion with air	0-120 seconds (60 seconds factory pre-set)
------------------------	---

Bed flush with air and water	0-10 minutes (420 seconds factory pre-set)
------------------------------	---

Bed Re-level with air only	0-60 seconds (30 seconds factory pre-set)
----------------------------	--

Bed settle	0-60 seconds (40 seconds factory pre-set)
------------	--

Rinse to waste	0-10 minutes (300 seconds factory pre-set)
----------------	---

#### Filter Backwash Step Time Ranges:

Backwash Pump Delay	0-10 seconds (5 seconds factory pre-set)
---------------------	---

Backwash Line Air Removal	0-60 seconds (30 seconds factory pre-set)
---------------------------	--

Low-Rate water with air	0-10 minutes (120 sec. factory pre-set)
-------------------------	--

Air Purge	0-120 seconds (30 sec. factory pre-set)
-----------	--

High Rate Water	0-10 minutes (300 sec. factory pre-set)
-----------------	--

Filter to Waste Minimum	0-15 minutes (10 minutes factory pre-set)
-------------------------	--

Filter to waste Maximum	0-30 minutes (20 minutes factory pre-set)
-------------------------	--

## HMI Screens

### Unit (X) Control Screens

The following controls are typically included on one or more screens. Which screens and screen content that is included may vary with each project's requirements.

Mode (Manual / Off / Auto)

Manual - is a call for the unit to run without the automatic call from SCADA or the clearwell start level. Everything runs as if the unit is in automatic except the plant will continue to run until someone takes the unit out of manual or a shutdown alarm occurs. The mode selector should be on the unit control screen.

Off – The plant control will remain off unless the valves and pumps are operated manually from the OIT.

Auto – The plant will start and stop automatically when called from SCADA or the clearwell control levels. All valves and pumps must be in automatic or an alarm sounds to alert the operator of the problem and prohibits the unit from starting.

Filter to Waste Valve Override (OFF / ON)

The Filter to Waste Override mode may be activated at any time during operation. During Filter to Waste Override the unit effluent flow is directed to drain through the filter to waste valve instead of to service through the Effluent valve. If this feature is forced on during the drain down portion of the backwash it will drain down through the Filter to Waste Valve. This feature control is on the unit control screen. Note – the override allows the flow to be directed to filter to waste without having to force the FTW valve in manual.

Clarifier Waste Gate Override (OFF/ON). The clarifier to waste override allows the operator to direct the water to waste after the clarifier and before the filter. This allows for getting rid of poor process water without having to run the water through the filter. Note – the override allows the flow to be directed to waste without having to force the waste gate in manual.

Unit Control HOA

Backwash Initiate Pushbutton

Flush Initiate Pushbutton

Cycle Cancel Pushbutton

Flush Cause Indication

Backwash Cause Indication

Flush On Time Setpoint In (xxx.x hrs)

Backwash On Time Setpoint In (xxx.x hrs)

Time remaining for the next flush or backwash initiation

High Turbidity Warning Setpoint x.xx NTU

High Turbidity Shutdown Setpoint x.xx NTU

High Filter Level Alarm Setpoint xx.xx in

Low Filter Level Alarm Setpoint xx.xx in

Operating Level Setpoint xx.xx in

Goto button for Unit X Manual Control Screen

Goto button for Backwash Setpoints

Goto button for Flush Setpoints

Goto button for Overview Screen

### **Unit (X) Manual Controls Screen**

Effluent pump Hand/Off/Auto

Inlet Valve Manual/Auto - ###.# % status – manual setpoint ###.# %

Waste Gate Open/Close/Auto

Filter Air Valve Open/Close/Auto

Clarifier Air Valve Open/Close/Auto

Filter To Waste Valve Manual/Auto - ###.# % status – manual setpoint  
###.# %

Effluent Valve Manual/Auto - ###.# % status – manual setpoint ###.# %

Backwash Supply Valve Manual/Auto - ###.# % status – manual setpoint  
###.# %

Flush Supplement Valve Manual/Auto - ###.# % status – manual  
setpoint ###.# %

Backwash Supply Valve Open/Close/Auto

Valve Signal Status Indicators (Open/Close) except for Modulating  
valves

### **Plant Manual Controls Screen**

Plant control HOA

Air Blower Hand/Off/Auto

Common Backwash Pump Hand/Off/Auto

High Rate Backwash Valve Open/Close/Auto

Status Indicator for each common valve/pump

Pump Status (Stop/Run/Fail/Call)

Goto button for Overview Screen

Goto button for Unit X Control

### **Backwash Set Points Screen**

All adjustable timer set points and their accumulated values

Draindown Level Set Point

Refill Level Set Point

### **Flush Set Points Screen**

All adjustable timer set points and their accumulated values

### **Alarms**

- Unit High Filter Level – Anytime the filter level reaches this analog operator adjustable level alarm setpoint, the unit is shut down and an alarm is sounded.
- Unit Low Filter Level Alarm – Anytime the filter level reaches this analog operator adjustable level alarm setpoint, the unit is shut down and an alarm is sounded. This alarm is disabled when the unit is in backwash.
- High AC Pressure – Starts an AC flush automatically after a 60-180 second timer.
- Unit High-High AC Pressure - Shuts the unit down and sounds an alarm.
- Unit High Turbidity Warning – Sounds an alarm and puts the unit into the Filter to Waste cycle to try and lower the effluent Turbidity to an acceptable setpoint. If not, a backwash is initiated.
- Unit High Turbidity Shutdown – If during the backwash Filter to Waste step, the Turbidity does not reach an acceptable setpoint and the maximum Filter to Waste timer times out, the unit shuts down and sounds an alarm. In addition if the filter to waste on startup turbidity is not below the setpoint before the maximum filter to waste on startup time is done then the unit will shut down on high effluent turbidity.
- No air during backwash cycle Backwash Failure – Sound and display Alarm.

**STANTEC**  
**THIS PAGE ONLY**  
**NO EXCEPTION TAKEN**

- Blower pressure failure during a flush cycle. Each unit is shut down when the blower pressure fails during its flush cycle..
- Unit Valves Not in Auto – If the unit is trying to run and the valves and pumps are not in automatic sound an alarm and don't allow the unit to go online, flush, or backwash.
- Unit Low Flow Shutdown Alarm
- Blower pressure failure during a backwash cycle (Just a warning alarm)

**STANTEC**  
**THIS PAGE ONLY**  
**NO EXCEPTION TAKEN**

SUBMITTAL  
Do Not Use  
For Installation

# SECTION 2

Master CP Drawings

**STANTEC**  
**THIS PAGE ONLY**  
**NO EXCEPTION TAKEN**

SUBMITTAL  
Do Not Use  
For Installation

This Page was left blank intentionally.

# TMWA MT. ROSE, NV TRIDENT HS PACKAGE SYSTEM MASTER CONTROL PANEL

**STANTEC**  
**THIS PAGE ONLY**  
**NO EXCEPTION TAKEN**

INTEGRATED CONTROLS, INC.  
15707 S. Manterville St  
Olathe, KS 66062  
Phone: (913) 782-9600  
Fax: (913) 764-7828

THIS DRAWING CONTAINS MATERIAL AND/OR INFORMATION WHICH IS THE PROPERTY OF INTEGRATED CONTROLS, INC. AND SUPPLIED ONLY ON CONFIDENTIAL BASIS. NO TRANSMITTAL OR DISCLOSURE SHALL BE MADE TO ANY PERSON, FIRM, OR CORPORATION WITHOUT PRIOR WRITTEN APPROVAL OF INTEGRATED CONTROLS, INC.

REV	DATE	DESCRIPTION	BY	APP'D
1	7-19-18	7-19-18	TH	DC

TMWA MT. ROSE, NV  
TRIDENT HS PACKAGE SYSTEM  
MASTER CONTROL PANEL  
COVER SHEET

DRAWN BY:	TH
CHECKED BY:	GR
SCALE:	NONE
DATE:	3-29-18
PROJECT#:	03694-01-00
SHEET #:	1 OF 8

ELECTRICAL SYMBOLS	CONTROL PANEL SPECIFICATIONS
<p><b>TERMINAL BLOCKS:</b> (PANEL MOUNTED) (REMOTE MOUNTED)</p> <p><b>CIRCUIT BREAKER:</b> CB1 20AMPS</p> <p><b>DISCONNECT SWITCH:</b> DS1 100AMPS</p> <p><b>FUSE:</b> FU1 10A</p> <p><b>GROUND:</b> </p> <p><b>COILS:</b> Control Relays, Timers, Motor Starters, etc. CR1 (Control Relay), TD1 (Timer Relay), MS1 (Motor Starter)</p> <p><b>CONTACTS:</b> Control Relays, Timers, Motor Starters, etc. CR1 (Local), CR1 (Remote), OL1 (Overload Relay)</p> <p><b>SWITCHES AND PUSHBUTTONS:</b> (SELECTOR) SS1, (N.O. PUSHBUTTON) PB1, (N.C. PUSHBUTTON) PB1, (MECHANICAL INTERLOCK)</p> <p><b>WIRING:</b> CONNECTION (LOCAL WIRING), NO CONNECTION, CONNECTION (REMOTE WIRING)</p> <p><b>Pressure Switch:</b> PS1 (N.O.), PS1 (N.C.) <b>Flow Switch:</b> FS1 (N.O.), FS1 (N.C.) <b>Float Switch:</b> FLT1 (N.O.), FLT1 (N.C.) <b>Temperature Switch:</b> TAS1 (N.O.), TAS1 (N.C.) <b>Limit Switch:</b> LS1 (N.O.), LS1 (N.O. HELD CLOSED), LS1 (N.C.), LS1 (N.C. HELD OPEN)</p> <p><b>Solenoid Valves:</b> SOL1 (Local), SOL1 (Remote) <b>Heater Coil:</b> HC1 <b>Indication (Pilot) Lamps:</b> LT1 (Green), LT1 (Red), LT1 (Blue), LT1 (White), LT1 (Amber) <b>Push to Test:</b>  <b>Electrical Outlet 120VAC OR 220VAC:</b> RECEPT1</p> <p><b>Resistor:</b> R1 OHMS <b>Diodes:</b> D1, D1 <b>Horn:</b> AH1 <b>Transformer:</b> XF1 <b>Suppressor:</b> SUP1</p> <p><b>PNEUMATIC SYMBOLS:</b> <b>Needle Valve:</b> GVA1 <b>Bulkhead:</b> </p>	<p><b>CONTROL PANEL UL LISTED:</b> <input type="checkbox"/> NOT LISTED <input checked="" type="checkbox"/> 508A (INDUSTRIAL CONTROL PANELS) <input type="checkbox"/> 698A (INDUSTRIAL CONTROL PANELS RELATING TO HAZARDOUS (CLASSIFIED) LOCATIONS)</p> <p><b>WIRE TYPE &amp; SIZE:</b> POWER: <input checked="" type="checkbox"/> MTW #14 <input type="checkbox"/> THHN # <input type="checkbox"/> SIS # <input type="checkbox"/> OTHER: CONTROL: <input checked="" type="checkbox"/> MTW #16 <input type="checkbox"/> THHN # <input type="checkbox"/> SIS # <input type="checkbox"/> OTHER: ANALOG SIGNAL: <input checked="" type="checkbox"/> SHIELDED #18</p> <p><b>SPECIAL WIRE ENDS:</b> <input checked="" type="checkbox"/> NONE <input type="checkbox"/> TIN <input type="checkbox"/> FERRULE <input type="checkbox"/> RING TERMINALS <input type="checkbox"/> OTHER:</p> <p><b>COLOR CODING:</b> AC HOT: BLACK AC NEUTRAL: WHITE AC SWITCHED (CONTROL): RED DC+: BLUE DC-: BLUE W/WHITE STRIPE DRY CONTACTS (FOREIGN VOLTAGE): YELLOW GROUND: GREEN</p> <p><b>WIRE TAGGING:</b> <input type="checkbox"/> NONE <input checked="" type="checkbox"/> SLEEVE (NON-SHRINK) <input type="checkbox"/> SLEEVE (SHRINK) <input type="checkbox"/> WRAP AROUND</p> <p><b>EQUIPMENT TAGGING:</b> ENGRAVING COLOR: <input checked="" type="checkbox"/> WHITE TEXT ON BLACK <input type="checkbox"/> BLACK TEXT ON WHITE <input type="checkbox"/> OTHER: PANEL DOOR: <input checked="" type="checkbox"/> ENGRAVED PHENOLIC (ADHESIVE MOUNT) <input type="checkbox"/> ENGRAVED PHENOLIC (SCREW MOUNT) BACK PANEL TYPE: <input checked="" type="checkbox"/> P-TOUCH (LAMINATED) <input type="checkbox"/> OTHER: DIN RAIL: <input checked="" type="checkbox"/> STEEL <input type="checkbox"/> ALUMINUM <input type="checkbox"/> COPPER</p> <p><b>NOTES:</b> 1. ALL DEVICES SHOWN REMOTELY MOUNTED OR WIRED REMOTELY ARE PROVIDED, MOUNTED AND CONNECTED BY OTHERS UNLESS SPECIFICALLY IDENTIFIED AS BEING SUPPLIED BY INTEGRATED CONTROLS, INC (ICI). DEVICES SPECIFICALLY IDENTIFIED AS BEING SUPPLIED BY ICI BUT ARE NOT MOUNTED IN THE CONTROL PANEL ARE MOUNTED AND CONNECTED BY OTHERS. 2. ALL ANALOG SIGNALS, PANEL INTERNAL WIRING OR FIELD WIRING, BOTH CURRENT AND VOLTAGE TYPES ARE TO BE WIRED IN BRAID SHIELDED TWISTED PAIR MULTI-CONDUCTOR CABLE. FIELD ANALOG WIRING IS NOT TO BE INSTALLED IN SAME CONDUIT AS AC CONTROL WIRING OR POWER WIRING OF ANY KIND. 3. INSTALLATION OF EQUIPMENT SHOULD BE MADE WITH ICI DIAGRAMS MARKED "INSTALLATION DRAWINGS" WHICH WILL REFLECT THE CORRECT ELECTRICAL/PNEUMATIC CONNECTION POINTS. 4. (120VAC SYSTEMS ONLY) WHERE MORE THAN ONE VOLTAGE SUPPLY IS REQUIRED AT ONE CONTROL PANEL, ONLY ONE PHASE SHOULD BE USED. THIS WILL ENSURE THAT 120VAC IS THE HIGHEST POTENTIAL AVAILABLE IN THE PANEL.</p>

C:\msdcs\shared\_folders\volatiles\GAD Design Documents\PROTD PROJECTS\BASIC PROJECT START\001 Cover Sheet.dwg

C:\ES\2013\Shared Folders\volatile\CAD Design Documents\PROTD PROJECTS\BASIC PROJECT START\004 Interior Panel Layout.dwg

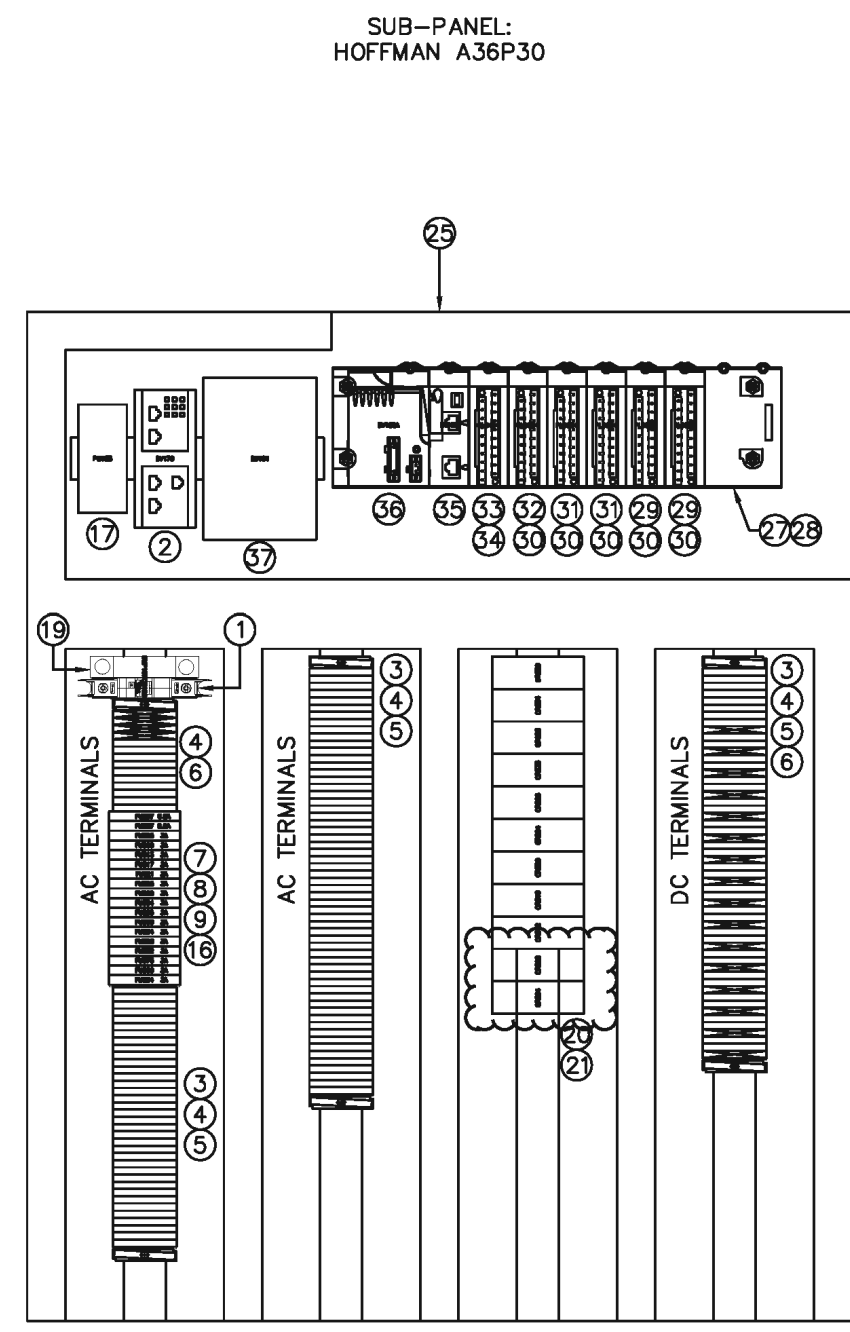
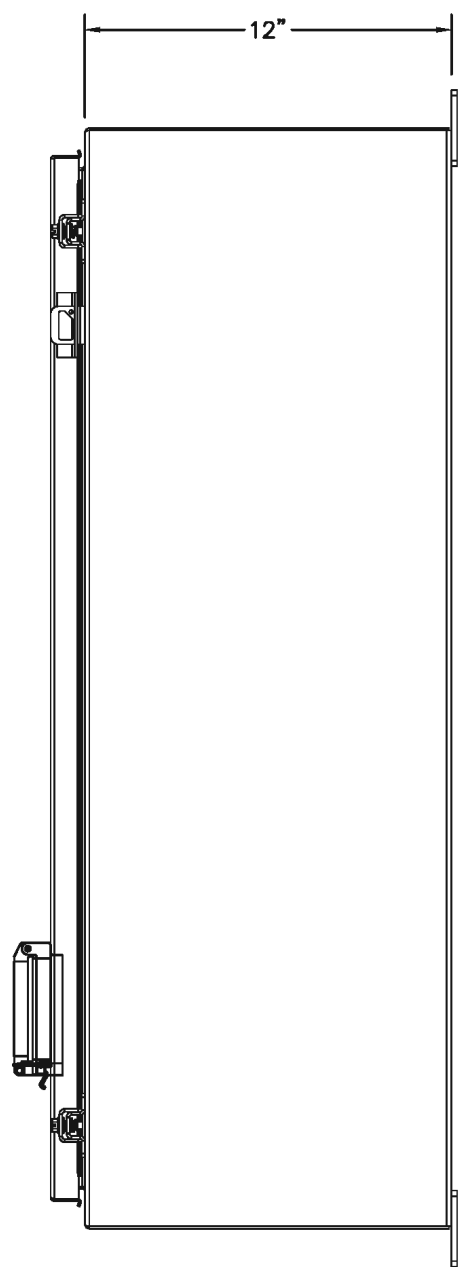
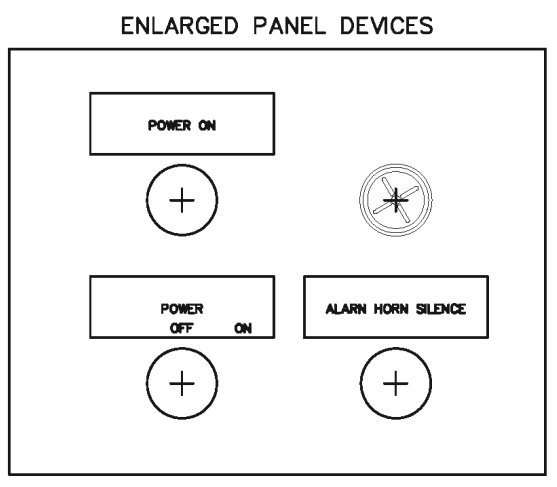
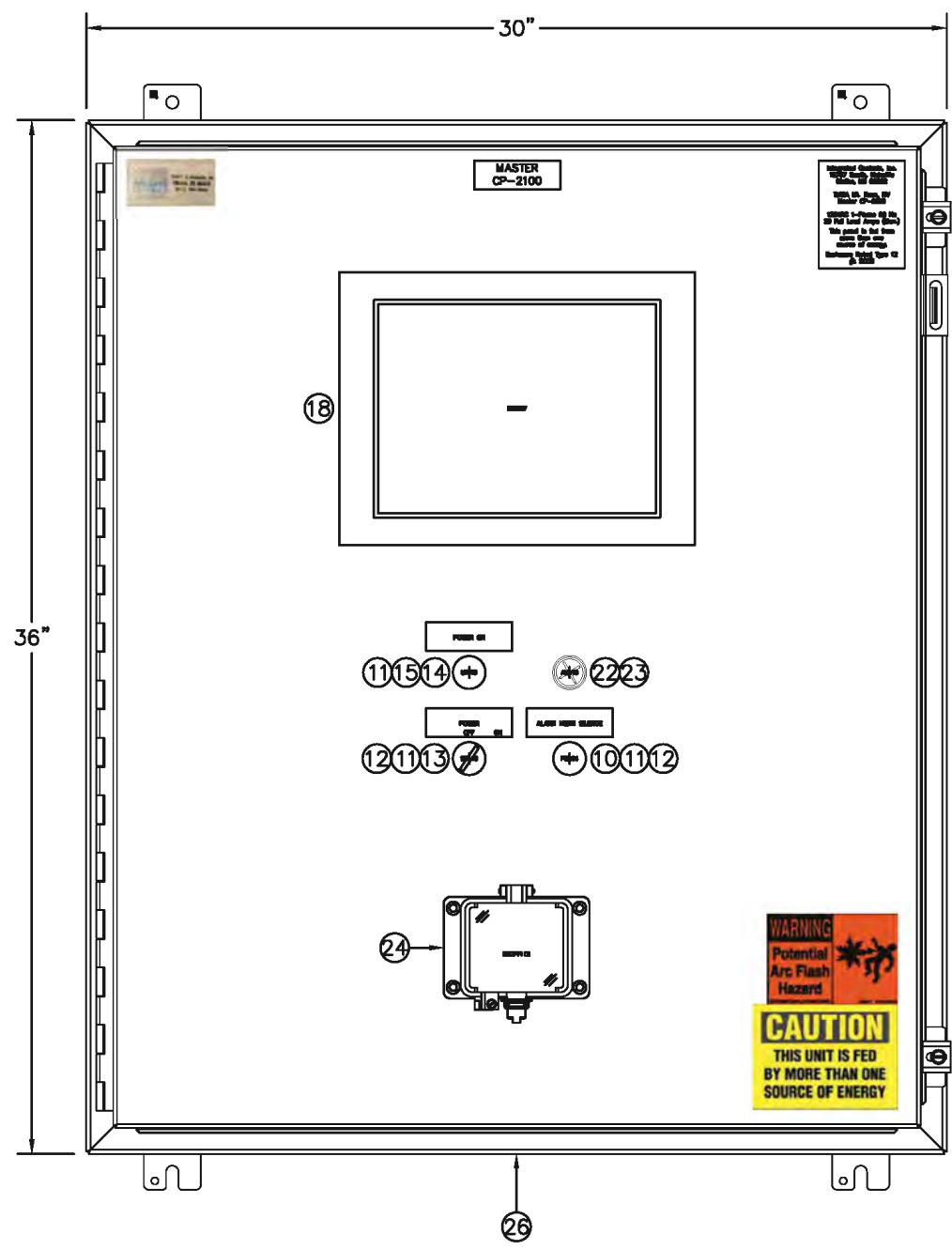

**THIS PAGE ONLY  
NO EXCEPTION TAKEN**

**STANTEC**  
INTEGRATED CONTROLS  
15707 S. Mohrville St  
Olathe, KS 66062  
Phone: (913) 782-9600  
Fax: (913) 784-7829

THIS DRAWING CONTAINS MATERIAL AND/OR INFORMATION WHICH IS THE PROPERTY OF INTEGRATED CONTROLS, INC. AND SUPPLIED ONLY ON CONFIDENTIAL BASIS. NO TRANSMITTAL OR DISCLOSURE SHALL BE MADE TO ANY PERSON, FIRM, OR CORPORATION WITHOUT PRIOR WRITTEN APPROVAL OF INTEGRATED CONTROLS, INC.

REV	DATE	DESCRIPTION	BY	APP'D
1	7-19-18	SUBMITTAL 1 COMMENTS	TH	DC

**TMWA MT. ROSE, NV  
TRIDET HS PACKAGE SYSTEM  
MASTER CONTROL PANEL  
PANEL LAYOUT**

DRAWN BY:	TH
CHECKED BY:	GR
SCALE:	NONE
DATE:	3-29-18
PROJECT#:	03694-01-00
SHEET #:	2 OF 8

THIS PAGE ONLY  
 NO EXCEPTION TAKEN

THIS DRAWING CONTAINS MATERIAL AND/OR INFORMATION WHICH IS THE PROPERTY OF INTEGRATED CONTROLS, INC. AND SUPPLIED ONLY ON CONFIDENTIAL BASIS. NO TRANSMITTAL OR DISCLOSURE SHALL BE MADE TO ANY PERSON, FIRM, OR CORPORATION WITHOUT PRIOR WRITTEN APPROVAL OF INTEGRATED CONTROLS, INC.

ITEM	CATALOG	MFG	DESC	TAGS
1	1489-M1C200	AB	20AMP, 1-POLE, M1C, CIRCUIT BREAKER, BULLETIN 1489 SERIES	CB104
2	9300-RADES	AB	REMOTE ACCESS DIAL-IN MODEM	DV170
3	1SNK900001R0000	ABB	BAM3 END STOP	
4	1SNK506010R0000	ABB	ZS6 GREY 6mm SCREW CLAMP TERMINAL BLOCK	
5	1SNK505910R0000	ABB	ES4 SCREW CLAMP TERMINAL BLOCK END COVER	
6	1SNK506150R0000	ABB	ZS6-PE 6mm SCREW CLAMP TERMINAL GROUNDING BLOCK	
7	1SNK508410R0000	ABB	ZS4-SF1 TERMINAL BLOCK FOR FUSES	FU237, FU287, FU305, FU309, FU313, FU317, FU321, FU325, FU329, FU334, FU355, FU360, FU365, FU369, FU373, FU377, FU381, FU385
8	0235003	LITTELFUSE	3.0 AMP FAST-ACTING CARTRIDGE FUSES, 5x20mm	FU305, FU309, FU313, FU317, FU321, FU325, FU329, FU334, FU355, FU360, FU365, FU369, FU373, FU377, FU381, FU385
9	1SNK508960R0000	ABB	ES4-SF TERMINAL BLOCK END COVER	
10	MP1-10B	ABB	NON-ILLUMINATED PUSH BUTTON, FLUSH, MOMENTARY, 22mm, BLACK	PB264
11	MCBH-00	ABB	MODULAR HOLDER	LT115, PB264, SS115
12	MCB-10	ABB	CONTACT BLOCK, 1 N.O.	PB264, SS115
13	M2SS1-10B	ABB	2 POSITION SELECTOR SWITCH (CENTER TO RIGHT), MAINTAINED, 22mm, BLACK	SS115
14	ML1-100W	ABB	PILOT LIGHT, MODULAR RANGE, WHITE LENS	LT115
15	MLBL-04W	ABB	120VAC WHITE LED PILOT LIGHT LAMP BLOCK	LT115
16	0235.500	LITTELFUSE	0.50 AMP FAST-ACTING CARTRIDGE FUSES, 5x20mm	FU237, FU287
17	1SVR427032R0000	ABB	CR-E 24VDC/2.5A POWER SUPPLY	PW153
18	HMI6310	SCHNEIDER ELECTRIC	MAGELIS GTO 12.1" TFT LCD TOUCHSCREEN HMI	HMI157
19	1B315015R136	EMCO	CR11E HS SURGE DIVERTER, 0c 170V, In 25kA, Imax 50kA	SUP107
20	55.32.8.120.0040	FINDER	IND. PLUG-IN RELAY, DPDT 10A, 120VAC COIL, AGNI CONTACT, LOCKABLE TEST BUTTON & MECH. INDICATOR	CR304, CR308, CR312, CR316, CR320, CR324, CR328, CR333, CR354, CR359, CR653
21	94.04	FINDER	RELAY SOCKET, DIN-RAIL/PANEL MOUNT, SCREW, 14 PINS, 10A, 250V	CR304, CR308, CR312, CR316, CR320, CR324, CR328, CR333, CR354, CR359, CR653
22	MB-V09-201-S(M)	FLOYD BELL	AUDIOLARM II ALARM HORN, VOLUME CONTROL, 30-120VAC	AH119
23	61663	FLOYD BELL	ALARM HORN GASKET	AH119
24	P-Q6R2-M3RF3	GRACEPORT	INSIDE/OUTSIDE OUTLET, GFCI, NEMA 12/4, ETHERNET, PHONE, 3A BREAKER	RECPT112
25	A36P30	HOFFMAN	SUB-PANEL, 31.00x27.00	
26	A363012LP	HOFFMAN	CONTINUOUS HINGE W/CLAMPS, TYPE 12 ENCLOSURE	
27	BMX XBP 0800	MODICON	M340 RACK, 8 SLOT	
28	BMX XEM 010	MODICON	PROTECTIVE COVER FOR UNUSED SLOTS ON M340 RACK	
29	BMX DRA 0805	MODICON	M340 DISCRETE RELAY OUTPUT MODULE	PLC303, PLC353
30	BMX FTB 2010	MODICON	M340 MODULE 20-WAY TERMINAL BLOCK, SCREW CLAMP	PLC204, PLC254, PLC303, PLC353, PLC504
31	BMX DAI 1604	MODICON	M340 DISCRETE INPUT MODULE	PLC204, PLC254
32	BMX AMO 0802	MODICON	M340 ANALOG OUTPUT MODULE, 8-CH	PLC504
33	BMX AMI 0810	MODICON	M340 ANALOG INPUT MODULE, 8-CH	PLC404
34	BMX FTB 2820	MODICON	M340 MODULE 28-WAY TERMINAL BLOCK, SPRING CLAMP	PLC404
35	BMX P34 2020	MODICON	M340 PERFORMANCE PROCESSOR MODULE	DV180
36	BMX CPS 2010	MODICON	M340 POWER SUPPLY MODULE - 17W	DV180A
37	ED5-516A	MOXA	16-PORT MANAGED ETHERNET SWITCH	DV161

REV	DATE	DESCRIPTION	BY	APP'D
1	7-19-18	SUBMITTAL 1 COMMENTS	TH	DC

**TMWA MT. ROSE, NV**  
**TRIDET HS PACKAGE SYSTEM**  
**MASTER CONTROL PANEL**  
**BILL OF MATERIAL**

DRAWN BY: TH  
 CHECKED BY: GR  
 SCALE: NONE  
 DATE: 3-29-18  
 PROJECT#: 03694-01-00  
 SHEET #: 3 OF 8

C:\Users\mz\Shared Folders\volatite\CAD Design Documents\PROJECTS\BASIC PROJECT START\200 Panel Equipment.dwg

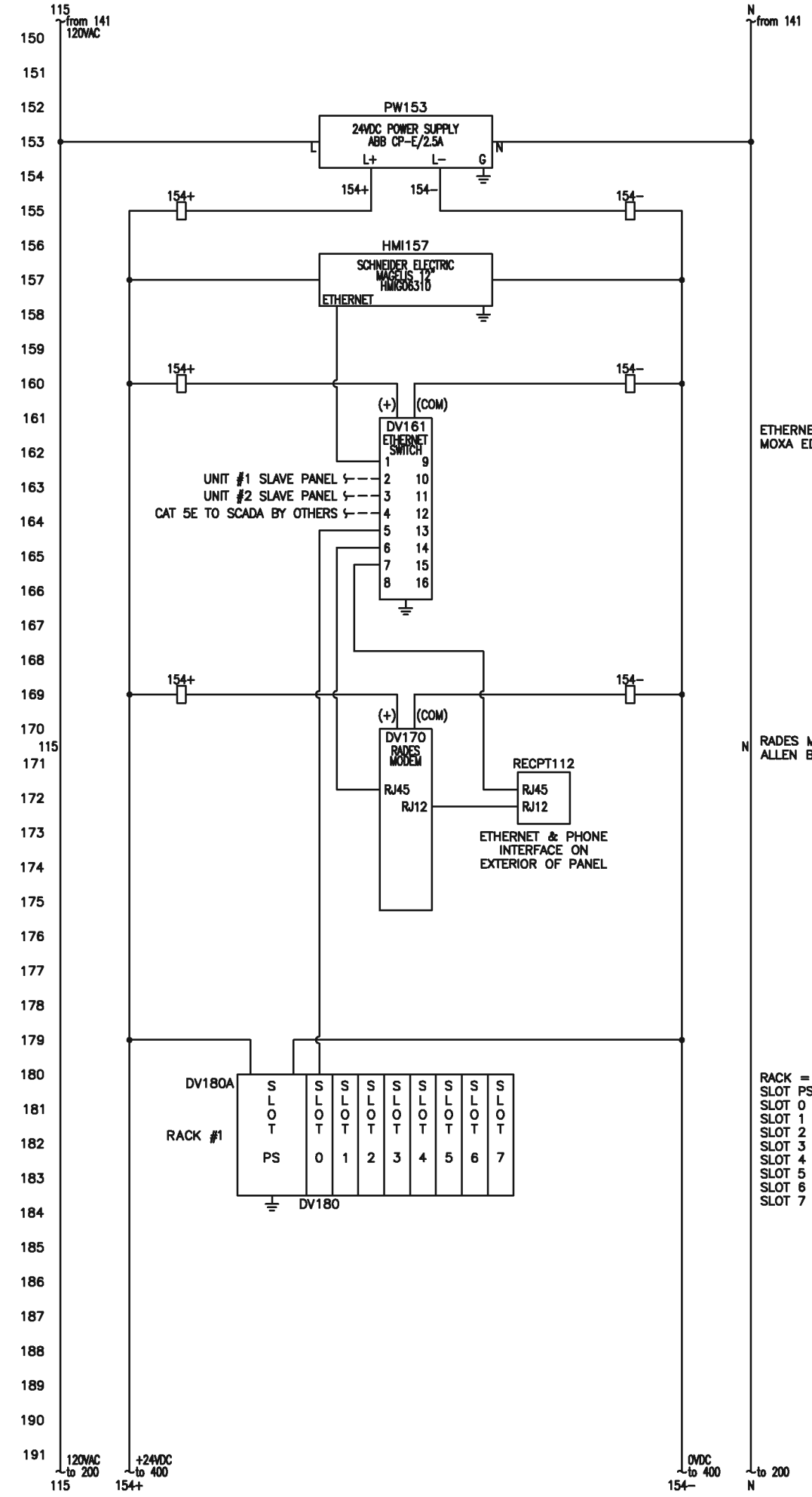
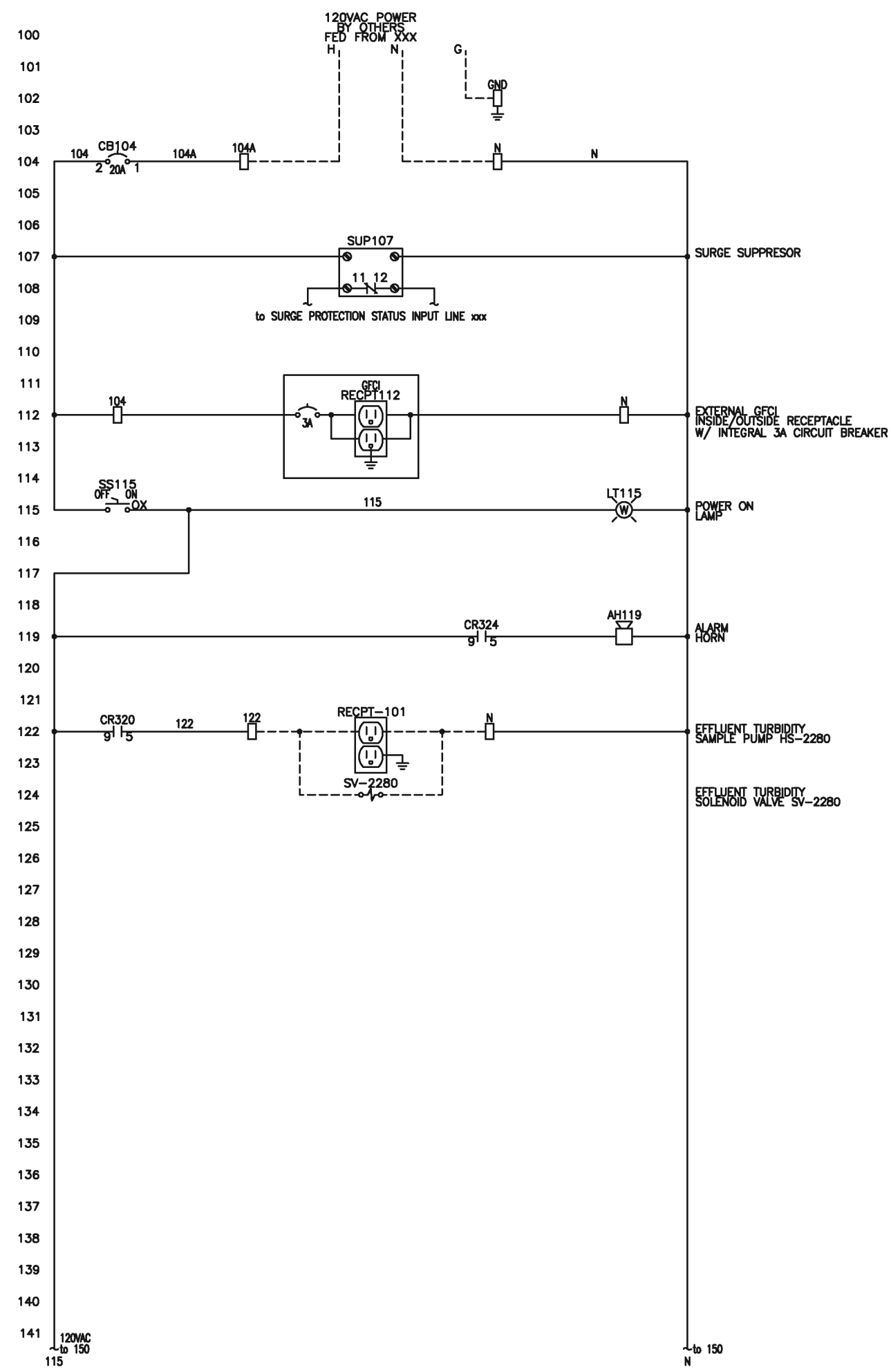

ETHERNET SWITCH  
 MOXA EDS-516A  
 RADES MODEM  
 ALLEN BRADLEY 9300-RADES

RACK = BMXXBP0800  
 SLOT PS = BMXCPS2010 POWER SUPPLY  
 SLOT 0 = BMXP342020 PLC  
 SLOT 1 = BMXAMIO810 ANALOG IN  
 SLOT 2 = BMXAMO0802 ANALOG OUT  
 SLOT 3 = BMXDAI1604 DISCRETE IN  
 SLOT 4 = BMXDAI1604 DISCRETE IN  
 SLOT 5 = BMXDRA0805 RELAY OUT  
 SLOT 6 = BMXDRA0805 RELAY OUT  
 SLOT 7 = BMXXEM010 EMPTY SLOT COVER

**STANTEC**  
**THIS PAGE ONLY**  
**NO EXCEPTION TAKEN**

INTEGRATED CONTROLS  
 15707 S. Mohrville St  
 Olathe, KS 66062  
 Phone: (913) 782-9600  
 Fax: (913) 784-7829

THIS DRAWING CONTAINS MATERIAL AND/OR INFORMATION WHICH IS THE PROPERTY OF INTEGRATED CONTROLS, INC. AND SUPPLIED ONLY ON CONFIDENTIAL BASIS. NO TRANSMITTAL OR DISCLOSURE SHALL BE MADE TO ANY PERSON, FIRM, OR CORPORATION WITHOUT PRIOR WRITTEN APPROVAL OF INTEGRATED CONTROLS, INC.

REV	DATE	DESCRIPTION	BY	APP'D
1	7-19-18	SUBMITTAL 1 COMMENTS	TH	DC

**TMWA MT. ROSE, NV**  
**TRIDET HS PACKAGE SYSTEM**  
**MASTER CONTROL PANEL**  
**SCHEMATICS**

DRAWN BY:	TH
CHECKED BY:	GR
SCALE:	NONE
DATE:	3-29-18
PROJECT#:	03694-01-00
SHEET #:	4 OF 8

\\ESS2013\Shared\Folders\volatiles\CAD Design Documents\PROJECTS\BASIC PROJECT START\300 Name.dwg

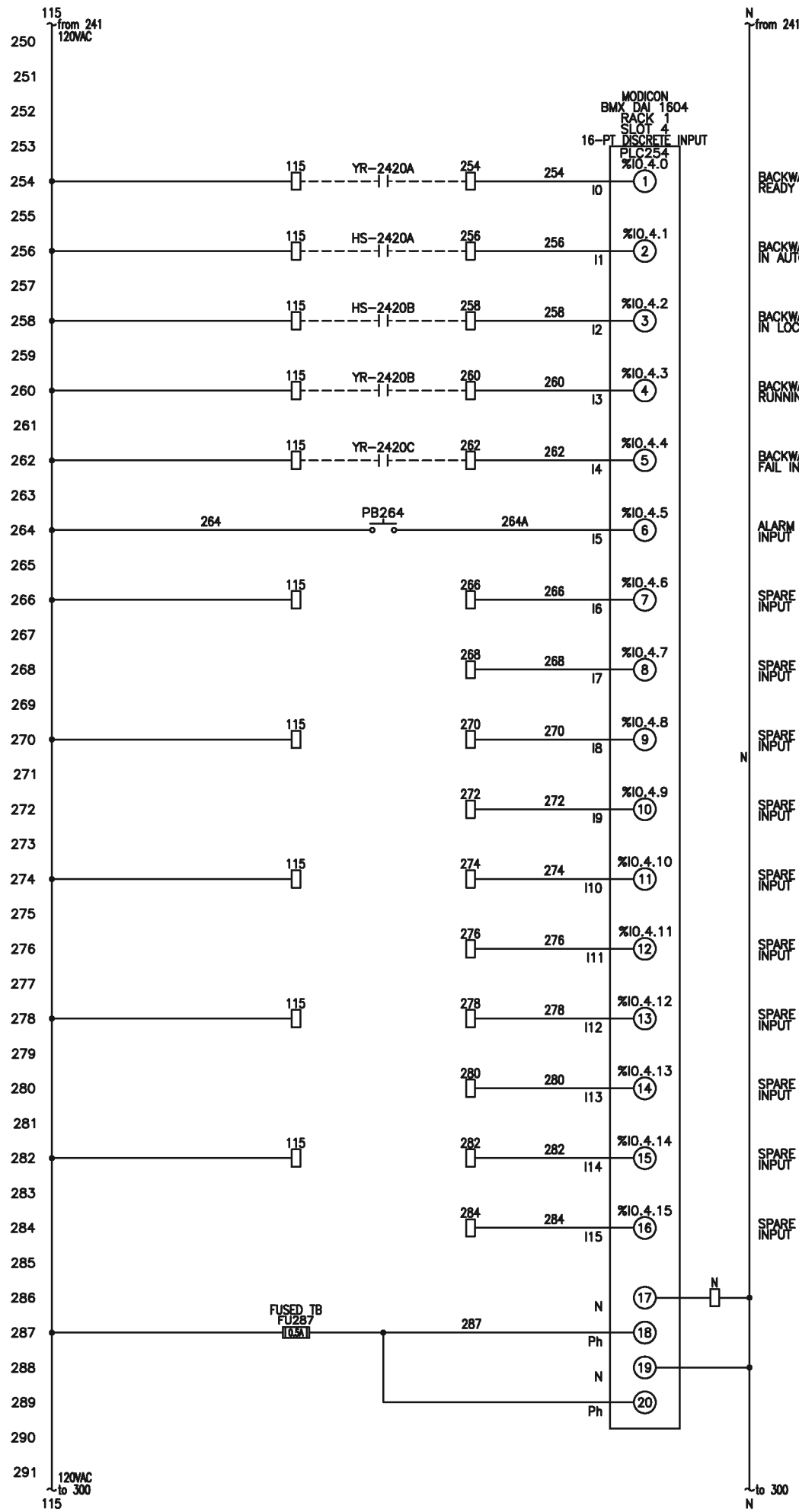
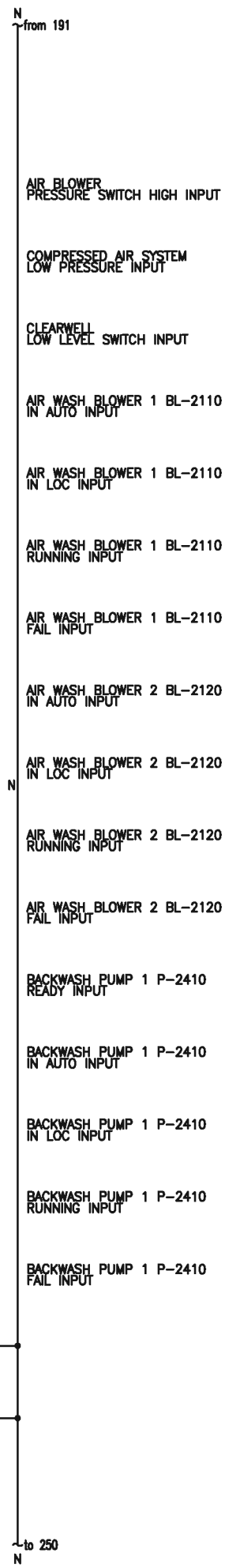
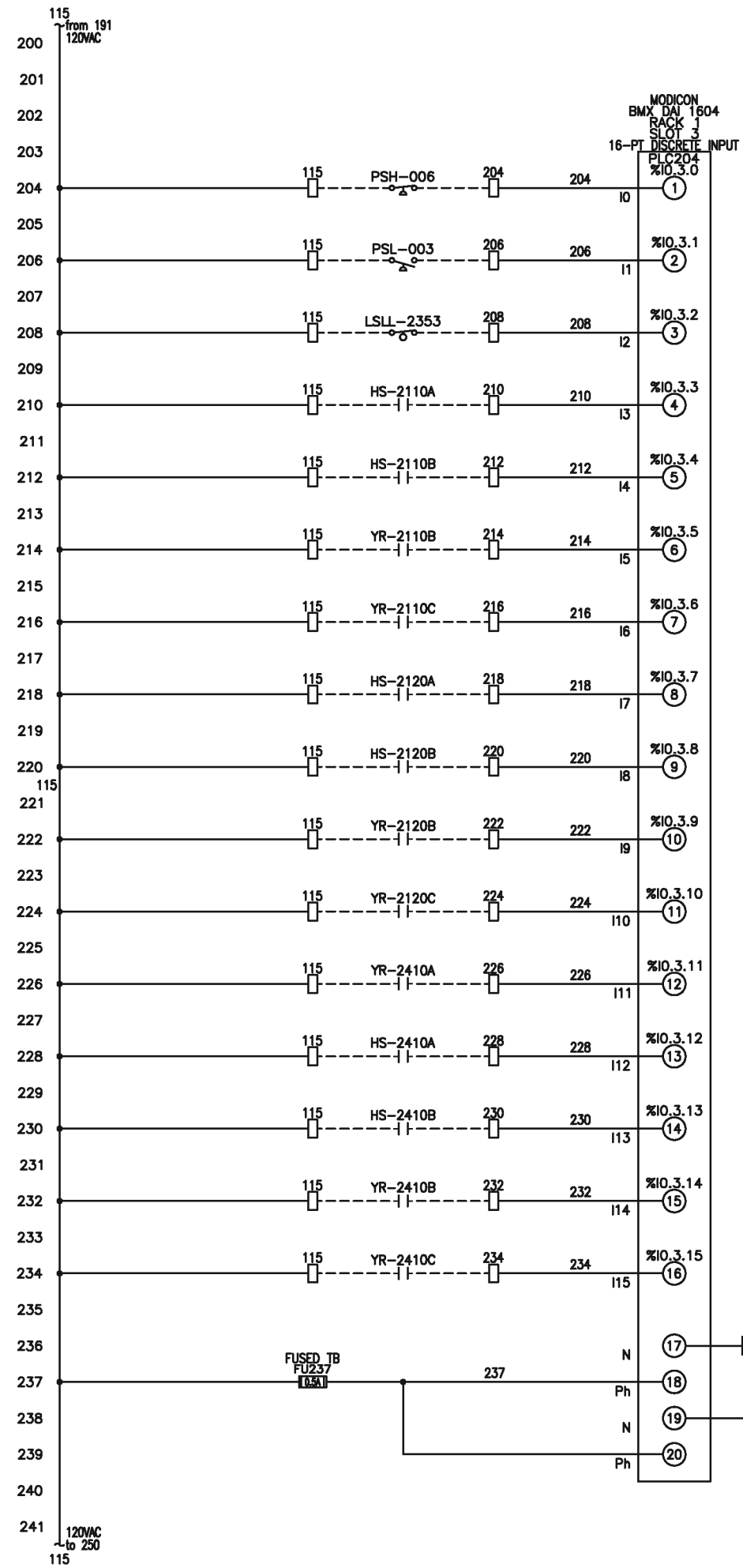

**STANTEC**  
**THIS PAGE ONLY**  
**NO EXCEPTION TAKEN**

INTEGRATED CONTROLS  
 15707 S. Monahie St  
 Olathe, KS 66062  
 Phone: (913) 782-9600  
 Fax: (913) 764-7829

THIS DRAWING CONTAINS MATERIAL AND/OR INFORMATION WHICH IS THE PROPERTY OF INTEGRATED CONTROLS, INC. AND SUPPLIED ONLY ON CONFIDENTIAL BASIS. NO TRANSMITTAL OR DISCLOSURE SHALL BE MADE TO ANY PERSON, FIRM, OR CORPORATION WITHOUT PRIOR WRITTEN APPROVAL OF INTEGRATED CONTROLS, INC.

REV	DATE	DESCRIPTION	BY	APP'D
1	7-19-18	SUBMITTAL 1 COMMENTS	TH	DC

**TMWA MT. ROSE, NV**  
**TRIDET HS PACKAGE SYSTEM**  
**MASTER CONTROL PANEL**  
**SCHEMATICS**

DRAWN BY:	TH
CHECKED BY:	GR
SCALE:	NONE
DATE:	3-29-18
PROJECT#:	03694-01-00
SHEET #:	5 OF 8

C:\msdcs\shared folders\volatiles\CAD Design Documents\PROJECTS\BASIC PROJECT STARTY\400 Name.dwg

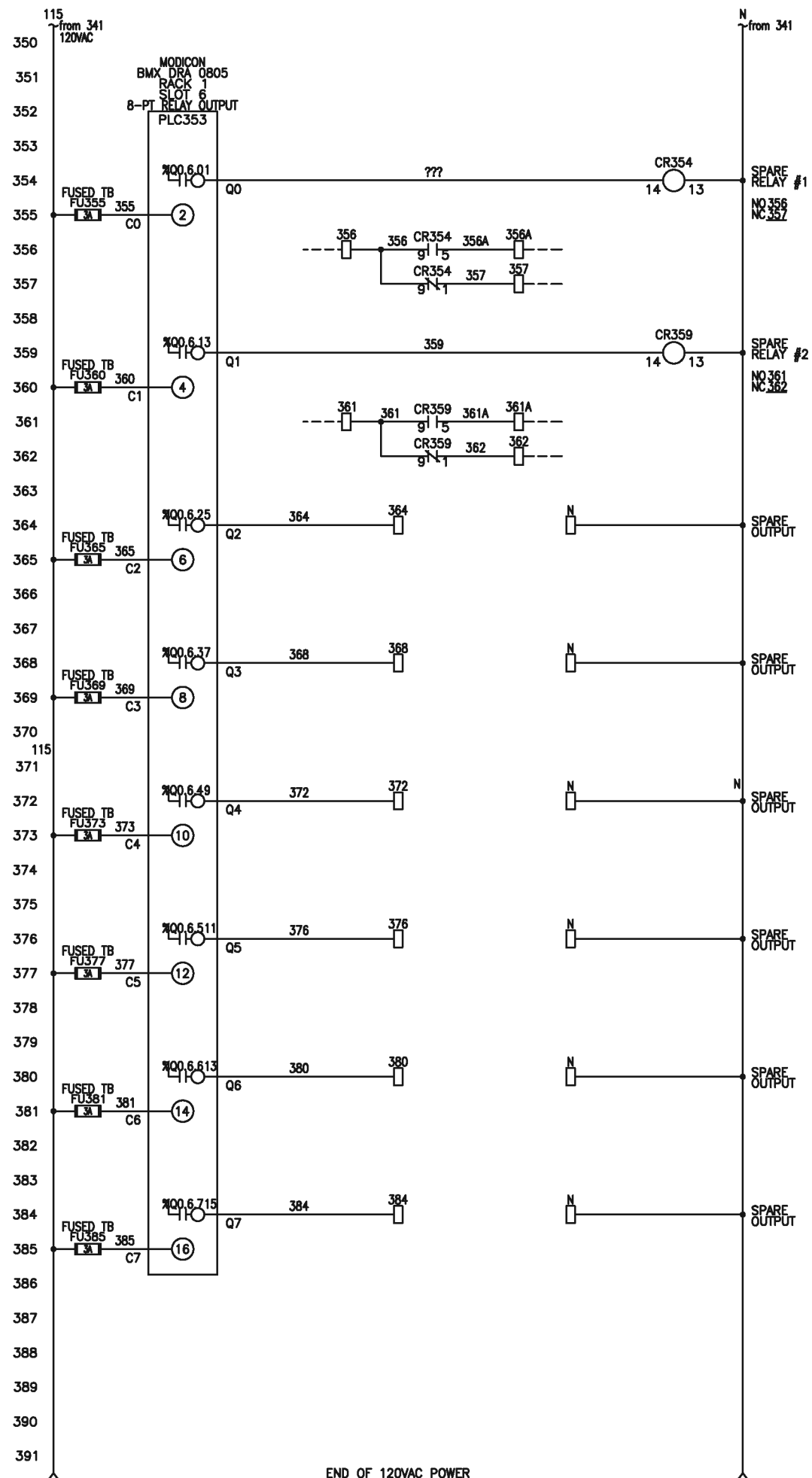
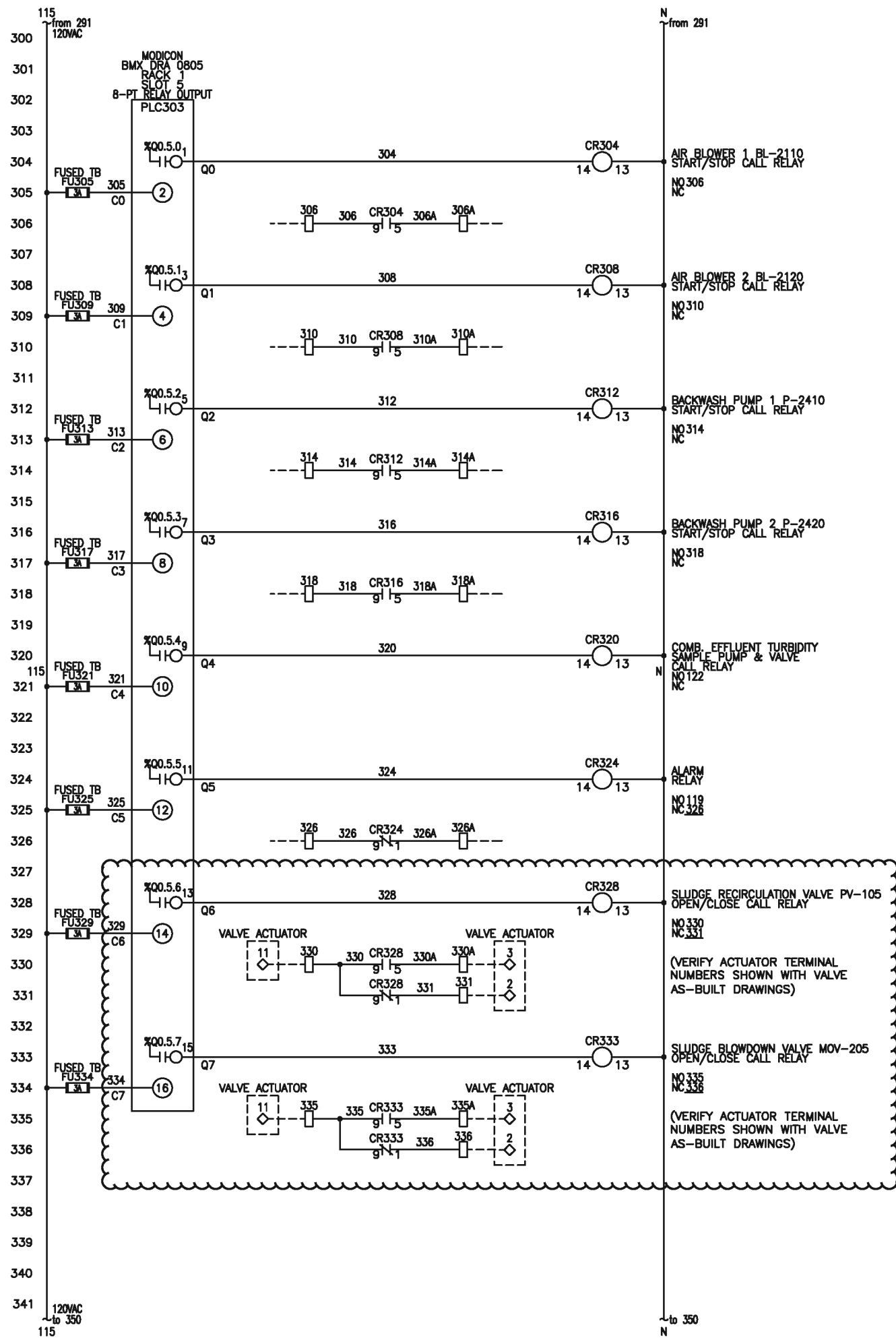

**STANTEC**  
**THIS PAGE ONLY**  
**NO EXCEPTION TAKEN**

**INTEGRATED CONTROLS**  
 15707 S. Moharrie St  
 Olathe, KS 66062  
 Phone: (913) 782-9600  
 Fax: (913) 782-7829

THIS DRAWING CONTAINS MATERIAL AND/OR INFORMATION WHICH IS THE PROPERTY OF INTEGRATED CONTROLS, INC. AND SUPPLIED ONLY ON CONFIDENTIAL BASIS. NO TRANSMITTAL OR DISCLOSURE SHALL BE MADE TO ANY PERSON, FIRM, OR CORPORATION WITHOUT PRIOR WRITTEN APPROVAL OF INTEGRATED CONTROLS, INC.

REV	DATE	DESCRIPTION	BY	APP'D
1	7-19-18	SUBMITTAL 1 COMMENTS	TH	DC

**TMWA MT. ROSE, NV**  
**TRIDET HS PACKAGE SYSTEM**  
**MASTER CONTROL PANEL**  
**SCHEMATICS**

DRAWN BY:	TH
CHECKED BY:	GR
SCALE:	NONE
DATE:	3-29-18
PROJECT#:	03694-01-00
SHEET #:	

c:\es2013\Shared Folders\volatite\CAD Design Documents\PROJECTS\BASIC PROJECT START\500 Name.dwg

400 154+ from 191 +24VDC  
 401  
 402  
 403  
 404  
 405  
 406  
 407  
 408  
 409  
 410  
 411  
 412  
 413  
 414  
 415  
 416  
 417  
 418  
 419  
 420 154+  
 421  
 422  
 423  
 424  
 425  
 426  
 427  
 428  
 429  
 430  
 431  
 432  
 433  
 434  
 435  
 436  
 437  
 438  
 439  
 440  
 441 +24VDC to 450 154+

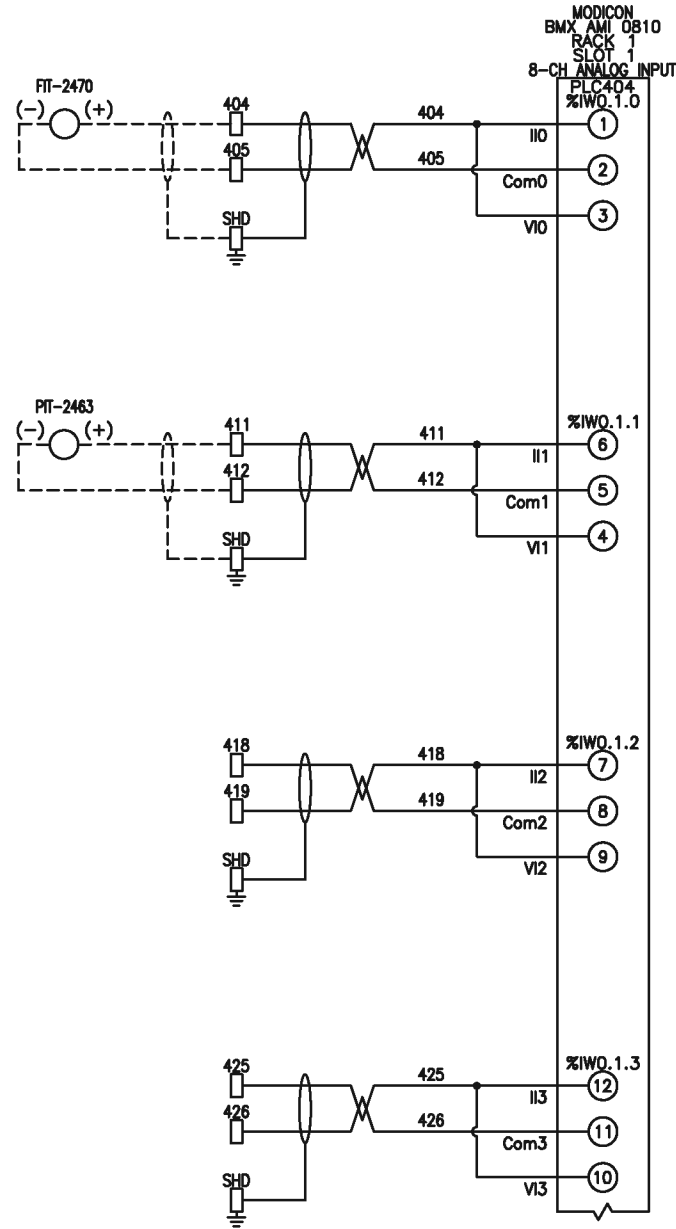

154- from 191 OVDC  
 BACKWASH FLOW-RATE INPUT  
 BACKWASH DISCHARGE PRESSURE INPUT  
 SPARE INPUT  
 SPARE INPUT  
 154- OVDC to 450 154+

450 154+ from 441 +24VDC  
 451  
 452  
 453  
 454  
 455  
 456  
 457  
 458  
 459  
 460  
 461  
 462  
 463  
 464  
 465  
 466  
 467  
 468  
 469  
 470 154+  
 471  
 472  
 473  
 474  
 475  
 476  
 477  
 478  
 479  
 480  
 481  
 482  
 483  
 484  
 485  
 486  
 487  
 488  
 489  
 490  
 491 +24VDC to 500 154+

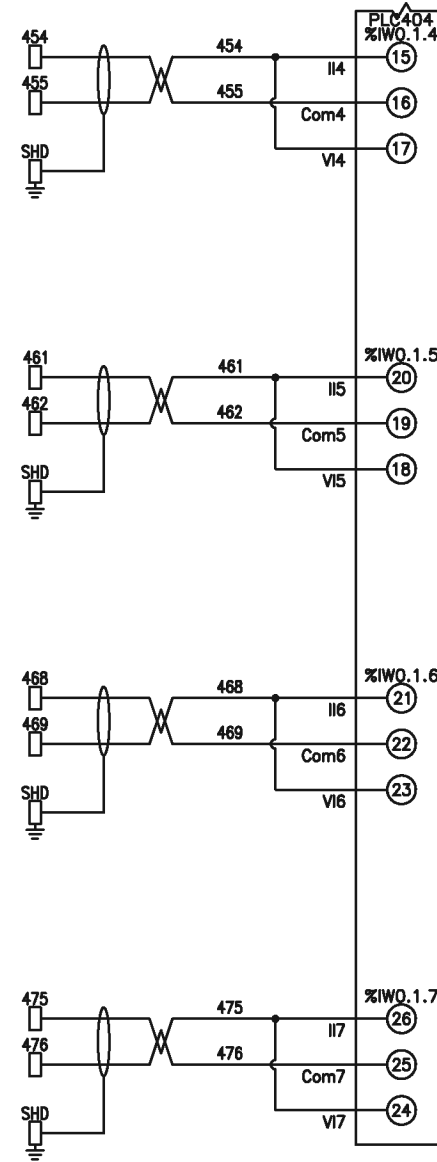

154- from 441 OVDC  
 SPARE INPUT  
 SPARE INPUT  
 SPARE INPUT  
 SPARE INPUT  
 154- OVDC to 500 154+

THIS PAGE ONLY  
 NO EXCEPTION TAKEN

**STANTEC**  
 INTEGRATED CONTROLS  
 15707 S. Monette St  
 Olathe, KS 66062  
 Phone: (913) 782-9600  
 Fax: (913) 764-7829

THIS DRAWING CONTAINS MATERIAL AND/OR INFORMATION WHICH IS THE PROPERTY OF INTEGRATED CONTROLS, INC. AND SUPPLIED ONLY ON CONFIDENTIAL BASIS. NO TRANSMITTAL OR DISCLOSURE SHALL BE MADE TO ANY PERSON, FIRM, OR CORPORATION WITHOUT PRIOR WRITTEN APPROVAL OF INTEGRATED CONTROLS, INC.

REV	DATE	DESCRIPTION	BY	APP'D
1	7-19-18	SUBMITTAL 1 COMMENTS	TH	DC

**TWVA MT. ROSE, NV  
 TRIDET HS PACKAGE SYSTEM  
 MASTER CONTROL PANEL  
 SCHEMATICS**

DRAWN BY:	TH
CHECKED BY:	GR
SCALE:	NONE
DATE:	3-29-18
PROJECT#:	03694-01-00
SHEET #	

c:\p1\m1\13\Shared Folders\volatiles\CAD Design Documents\PROJECTS\BASIC PROJECT START\600 Name.dwg

500 154+ from 491 +24VDC  
 501  
 502  
 503  
 504  
 505  
 506  
 507  
 508  
 509  
 510  
 511  
 512  
 513  
 514  
 515  
 516  
 517  
 518  
 519  
 520  
 521  
 522  
 523  
 524  
 525  
 526  
 527  
 528  
 529  
 530  
 531  
 532  
 533  
 534  
 535  
 536  
 537  
 538  
 539  
 540  
 541 +24VDC to 550 154+

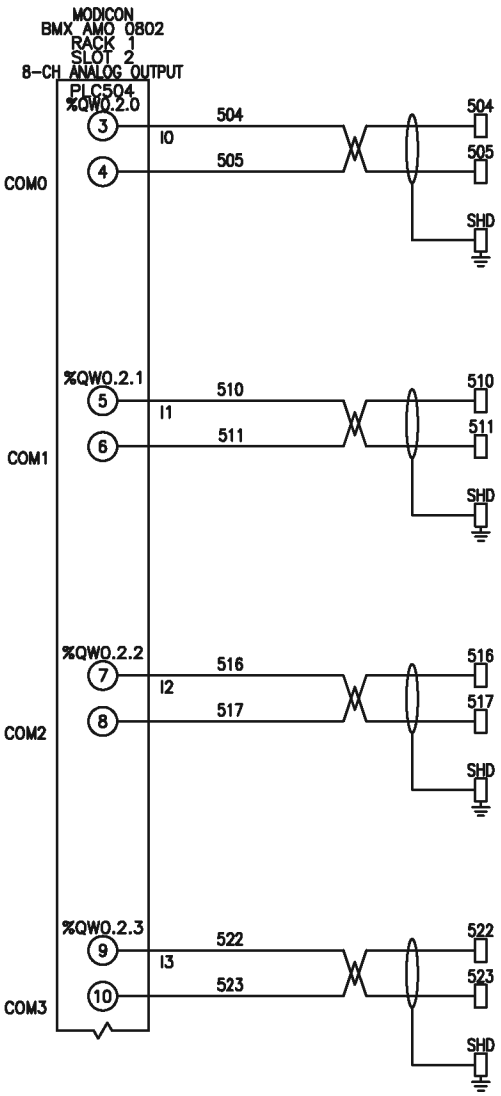

154- from 491 0VDC  
 SPARE OUTPUT  
 SPARE OUTPUT  
 SPARE OUTPUT  
 SPARE OUTPUT  
 154-  
 SPARE OUTPUT  
 0VDC to 550 154-

550 154- from 541 +24VDC  
 551  
 552  
 553  
 554  
 555  
 556  
 557  
 558  
 559  
 560  
 561  
 562  
 563  
 564  
 565  
 566  
 567  
 568  
 569  
 570  
 571 154-  
 572  
 573  
 574  
 575  
 576  
 577  
 578  
 579  
 580  
 581  
 582  
 583  
 584  
 585  
 586  
 587  
 588  
 589  
 590  
 591

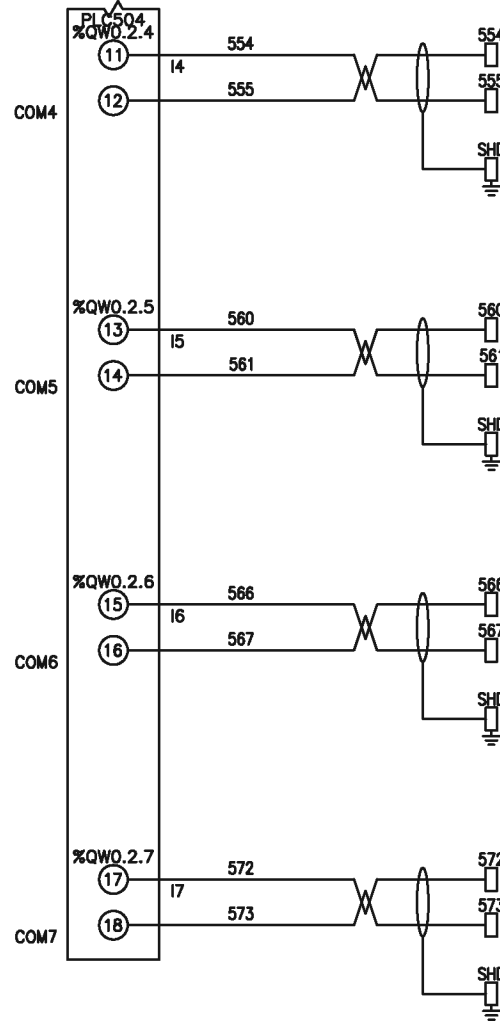

154- from 541 0VDC  
 SPARE OUTPUT  
 SPARE OUTPUT  
 SPARE OUTPUT  
 SPARE OUTPUT  
 154-  
 SPARE OUTPUT

END OF 24VDC POWER  
 END OF ELECTRICAL DRAWINGS

**STANTEC**  
**THIS PAGE ONLY**  
**NO EXCEPTION TAKEN**

**INTEGRATED CONTROLS**  
 15707 S. Mohafie St  
 Olathe, KS 66062  
 Phone: (913) 782-9800  
 Fax: (913) 764-7829

THIS DRAWING CONTAINS MATERIAL AND/OR INFORMATION WHICH IS THE PROPERTY OF INTEGRATED CONTROLS, INC. AND SUPPLIED ONLY ON CONFIDENTIAL BASIS. NO TRANSMITTAL OR DISCLOSURE SHALL BE MADE TO ANY PERSON, FIRM, OR CORPORATION WITHOUT PRIOR WRITTEN APPROVAL OF INTEGRATED CONTROLS, INC.

REV	DATE	DESCRIPTION	BY	APP'D
1	7-19-18	SUBMITTAL 1 COMMENTS	TH	DC

**TMWA MT. ROSE, NV**  
**TRIDET HS PACKAGE SYSTEM**  
**MASTER CONTROL PANEL**  
**SCHEMATICS**

DRAWN BY:	TH
CHECKED BY:	GR
SCALE:	NONE
DATE:	3-29-18
PROJECT#:	03694-01-00
SHEET #:	8 OF 8

**STANTEC**  
**THIS PAGE ONLY**  
**NO EXCEPTION TAKEN**

SUBMITTAL  
Do Not Use  
For Installation

# SECTION 3

**Slave CP 1 Drawings**

**STANTEC**  
**THIS PAGE ONLY**  
**NO EXCEPTION TAKEN**

SUBMITTAL  
Do Not Use  
For Installation

This Page was left blank intentionally.

# TMWA MT. ROSE, NV TRIDENT HS PACKAGE SYSTEM SLAVE CONTROL PANEL 1

**STANTEC**  
**THIS PAGE ONLY**  
**NO EXCEPTION TAKEN**

INTEGRATED CONTROLS, INC.  
15707 S. Mohrville St  
Olathe, KS 66062  
Phone: (913) 782-9600  
Fax: (913) 784-7829

THIS DRAWING CONTAINS MATERIAL AND/OR INFORMATION WHICH IS THE PROPERTY OF INTEGRATED CONTROLS, INC. AND SUPPLIED ONLY ON CONFIDENTIAL BASIS. NO TRANSMITTAL OR DISCLOSURE SHALL BE MADE TO ANY PERSON, FIRM, OR CORPORATION WITHOUT PRIOR WRITTEN APPROVAL OF INTEGRATED CONTROLS, INC.

REV	DATE	DESCRIPTION	BY	APP'D
1	7-19-18	7-19-18	TH	DC

TMWA MT. ROSE, NV  
TRIDENT HS PACKAGE SYSTEM  
SLAVE CONTROL PANEL 1  
COVER SHEET

DRAWN BY:	TH
CHECKED BY:	GR
SCALE:	NONE
DATE:	3-29-18
PROJECT#:	03694-01-00
SHEET #:	1 OF 9

ELECTRICAL SYMBOLS	CONTROL PANEL SPECIFICATIONS
<p><b>TERMINAL BLOCKS:</b> (PANEL MOUNTED) (REMOTE MOUNTED) </p> <p><b>CIRCUIT BREAKER:</b> CB1 20AMPS <b>DISCONNECT SWITCH:</b> DS1 100AMPS <b>FUSE:</b> FU1 10A <b>GROUND:</b> </p> <p><b>COILS:</b> Control Relays, Timers, Motor Starters, etc. CR1 (Control Relay), TD1 (Timer Relay), MS1 (Motor Starter)</p> <p><b>CONTACTS:</b> Control Relays, Timers, Motor Starters, etc. CR1 (Local), CR1 (Remote), OL1 (Overload Relay)</p> <p><b>SWITCHES AND PUSHBUTTONS:</b> (SELECTOR) SS1, (N.O. PUSHBUTTON) PB1, (N.C. PUSHBUTTON) PB1, (MECHANICAL INTERLOCK) </p> <p><b>WIRING:</b> CONNECTION </p> <p><b>PRESSURE SWITCH:</b> PS1 (N.O.), PS1 (N.C.) <b>FLOW SWITCH:</b> FS1 (N.O.), FS1 (N.C.) <b>FLOAT SWITCH:</b> FLT1 (N.O.), FLT1 (N.C.) <b>TEMPERATURE SWITCH:</b> TAS1 (N.O.), TAS1 (N.C.) <b>LIMIT SWITCH:</b> LS1 (N.O.), LS1 (N.O. HELD CLOSED), LS1 (N.C.), LS1 (N.C. HELD OPEN)</p> <p><b>SOLENOID VALVES:</b> SOL1 (Local), SOL1 (Remote) <b>HEATER COIL:</b> HC1 <b>INDICATION (PILOT) LAMPS:</b> LT1 (Green), LT1 (Red), LT1 (Blue), LT1 (White), LT1 (Amber) <b>PUSH TO TEST:</b> </p> <p><b>ELECTRICAL OUTLET 120VAC OR 220VAC:</b> RECEPT1 </p> <p><b>RESISTOR:</b> R1 OHMS <b>DIODES:</b> D1 <b>HORN:</b> AH1 <b>TRANSFORMER:</b> XF1 <b>SUPPRESSOR:</b> SUP1</p> <p><b>PNEUMATIC SYMBOLS:</b> <b>NEEDLE VALVE:</b> GVA1 <b>BULKHEAD:</b> </p>	<p><b>CONTROL PANEL UL LISTED:</b> <input type="checkbox"/> NOT LISTED <input checked="" type="checkbox"/> 508A (INDUSTRIAL CONTROL PANELS) <input type="checkbox"/> 698A (INDUSTRIAL CONTROL PANELS RELATING TO HAZARDOUS (CLASSIFIED) LOCATIONS)</p> <p><b>WIRE TYPE &amp; SIZE:</b> POWER: <input checked="" type="checkbox"/> MTW #14 <input type="checkbox"/> THHN # <input type="checkbox"/> SIS # <input type="checkbox"/> OTHER: CONTROL: <input checked="" type="checkbox"/> MTW #16 <input type="checkbox"/> THHN # <input type="checkbox"/> SIS # <input type="checkbox"/> OTHER: ANALOG SIGNAL: <input checked="" type="checkbox"/> SHIELDED #18</p> <p><b>SPECIAL WIRE ENDS:</b> <input checked="" type="checkbox"/> NONE <input type="checkbox"/> TIN <input type="checkbox"/> FERRULE <input type="checkbox"/> RING TERMINALS <input type="checkbox"/> OTHER:</p> <p><b>COLOR CODING:</b> AC HOT: BLACK AC NEUTRAL: WHITE AC SWITCHED (CONTROL): RED DC+: BLUE DC-: BLUE W/WHITE STRIPE DRY CONTACTS (FOREIGN VOLTAGE): YELLOW GROUND: GREEN</p> <p><b>WIRE TAGGING:</b> <input type="checkbox"/> NONE <input checked="" type="checkbox"/> SLEEVE (NON-SHRINK) <input type="checkbox"/> SLEEVE (SHRINK) <input type="checkbox"/> WRAP AROUND</p> <p><b>EQUIPMENT TAGGING:</b> ENGRAVING COLOR: <input checked="" type="checkbox"/> WHITE TEXT ON BLACK <input type="checkbox"/> BLACK TEXT ON WHITE <input type="checkbox"/> OTHER: PANEL DOOR: <input checked="" type="checkbox"/> ENGRAVED PHENOLIC (ADHESIVE MOUNT) <input type="checkbox"/> ENGRAVED PHENOLIC (SCREW MOUNT) BACK PANEL TYPE: <input checked="" type="checkbox"/> P-TOUCH (LAMINATED) <input type="checkbox"/> OTHER: DIN RAIL: <input checked="" type="checkbox"/> STEEL <input type="checkbox"/> ALUMINUM <input type="checkbox"/> COPPER</p> <p><b>NOTES:</b> 1. ALL DEVICES SHOWN REMOTELY MOUNTED OR WIRED REMOTELY ARE PROVIDED, MOUNTED AND CONNECTED BY OTHERS UNLESS SPECIFICALLY IDENTIFIED AS BEING SUPPLIED BY INTEGRATED CONTROLS, INC (ICI). DEVICES SPECIFICALLY IDENTIFIED AS BEING SUPPLIED BY ICI BUT ARE NOT MOUNTED IN THE CONTROL PANEL ARE MOUNTED AND CONNECTED BY OTHERS. 2. ALL ANALOG SIGNALS, PANEL INTERNAL WIRING OR FIELD WIRING, BOTH CURRENT AND VOLTAGE TYPES ARE TO BE WIRED IN BRAID SHIELDED TWISTED PAIR MULTI-CONDUCTOR CABLE. FIELD ANALOG WIRING IS NOT TO BE INSTALLED IN SAME CONDUIT AS AC CONTROL WIRING OR POWER WIRING OF ANY KIND. 3. INSTALLATION OF EQUIPMENT SHOULD BE MADE WITH ICI DIAGRAMS MARKED "INSTALLATION DRAWINGS" WHICH WILL REFLECT THE CORRECT ELECTRICAL/PNEUMATIC CONNECTION POINTS. 4. (120VAC SYSTEMS ONLY) WHERE MORE THAN ONE VOLTAGE SUPPLY IS REQUIRED AT ONE CONTROL PANEL, ONLY ONE PHASE SHOULD BE USED. THIS WILL ENSURE THAT 120VAC IS THE HIGHEST POTENTIAL AVAILABLE IN THE PANEL.</p>

C:\Users\mz\Shared Folders\CAD Design Documents\PROJECTS\BASIC PROJECT START\001 Cover Sheet.dwg

C:\pwworkspace\SSS2013\Shared Folders\volatile\CAD Design Documents\PROJECTS\BASIC PROJECT START\004 Interior Panel Layout.dwg

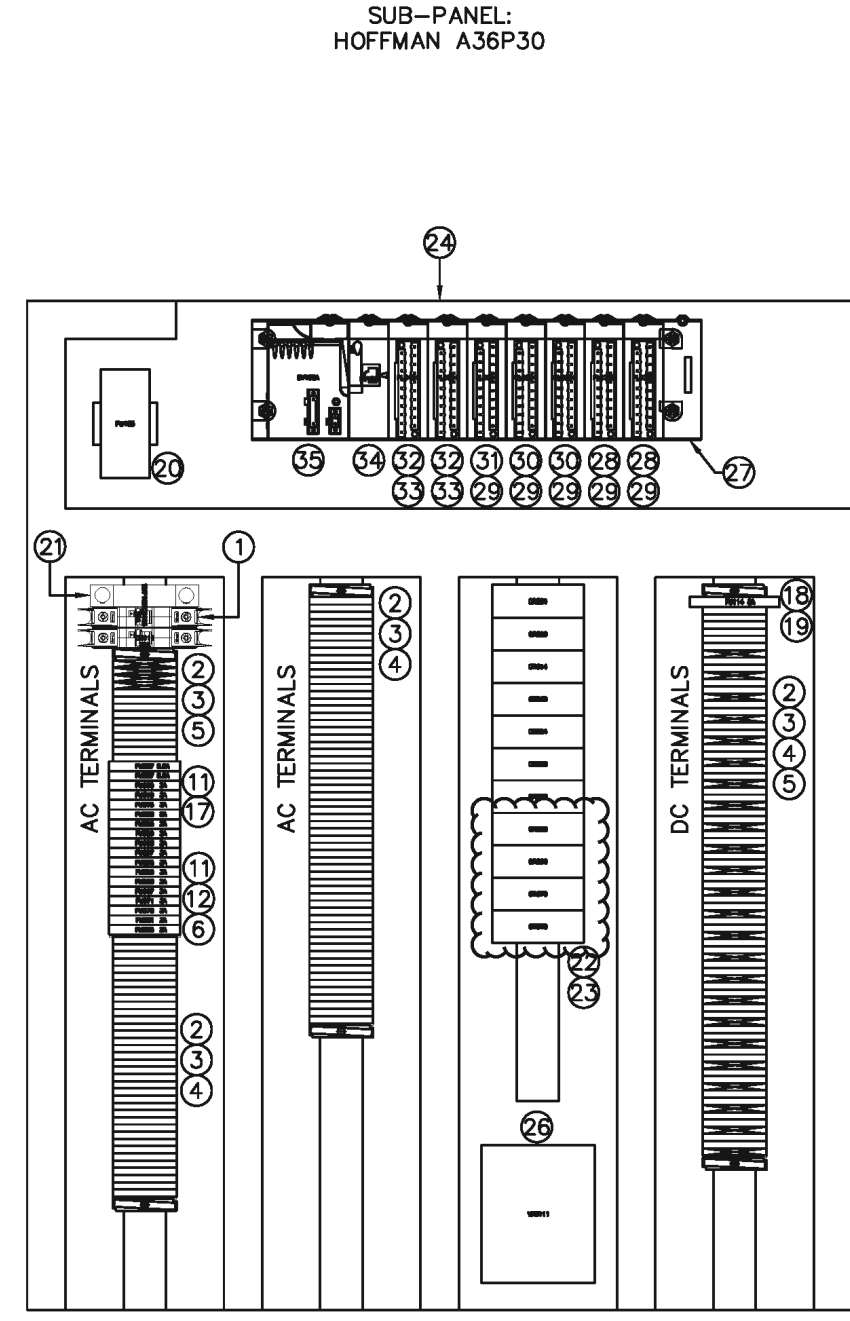
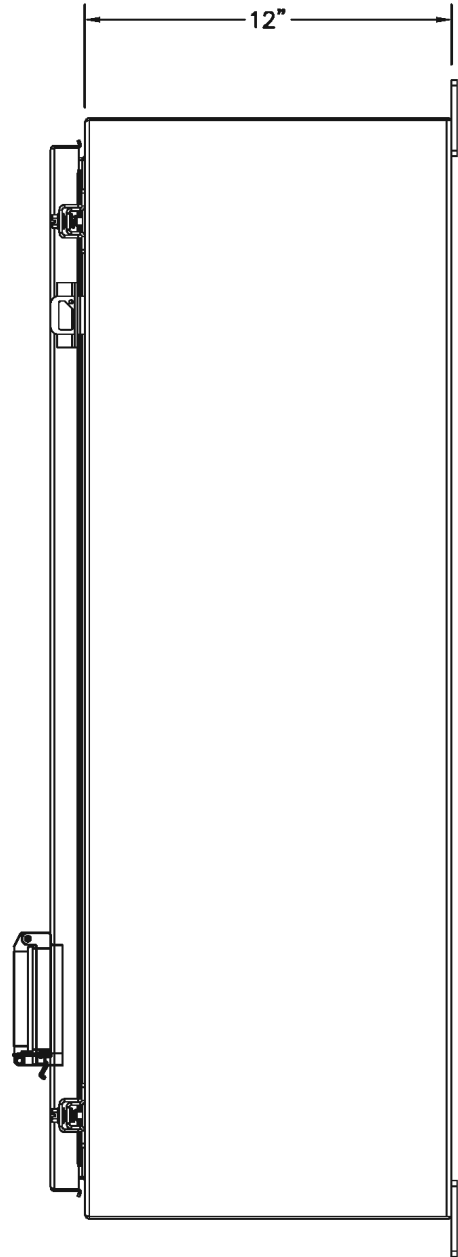
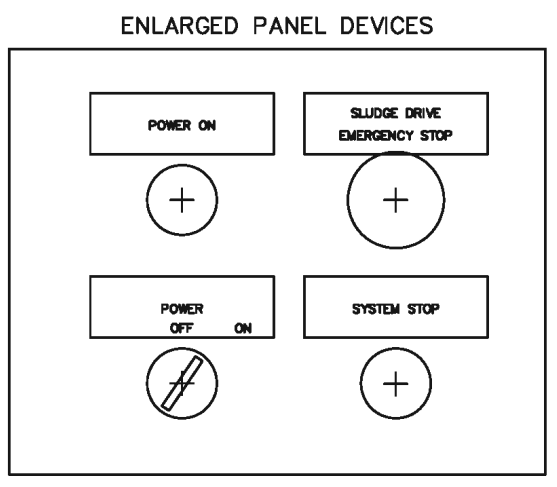
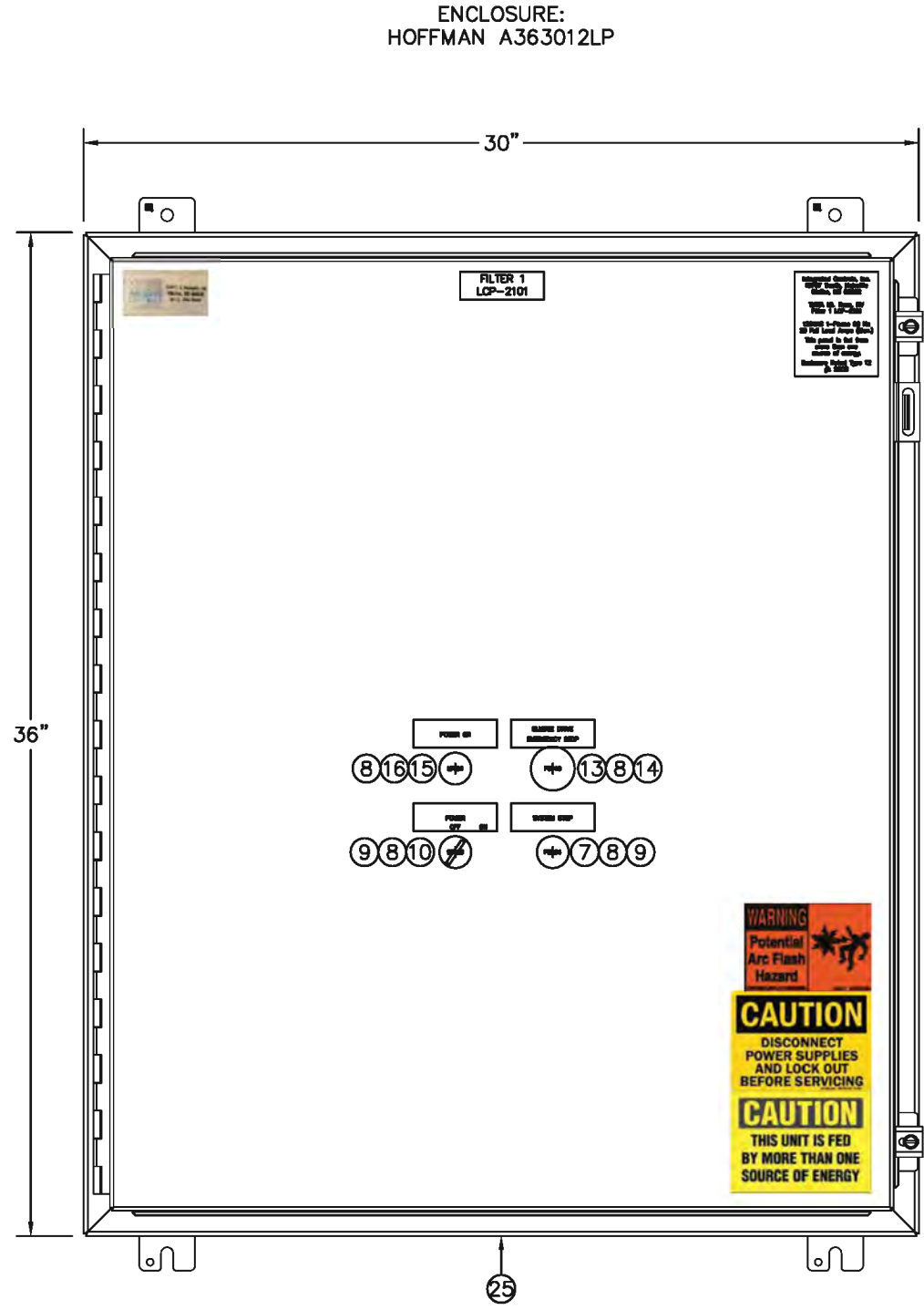

**STANTEC**  
**THIS PAGE ONLY**  
**NO EXCEPTION TAKEN**

**INTEGRATED CONTROLS**  
15707 S. Mohrville St  
Olathe, KS 66062  
Phone: (913) 782-9600  
Fax: (913) 764-7829

THIS DRAWING CONTAINS MATERIAL AND/OR INFORMATION WHICH IS THE PROPERTY OF INTEGRATED CONTROLS, INC. AND SUPPLIED ONLY ON CONFIDENTIAL BASIS. NO TRANSMITTAL OR DISCLOSURE SHALL BE MADE TO ANY PERSON, FIRM, OR CORPORATION WITHOUT PRIOR WRITTEN APPROVAL OF INTEGRATED CONTROLS, INC.

REV	DATE	DESCRIPTION	BY	APP'D
1	7-19-18	SUBMITTAL 1 COMMENTS	TH	DC

*TMWA MT. ROSE, NV*  
*TRIDET HS PACKAGE SYSTEM*  
*SLAVE CONTROL PANEL 1*  
*INTERIOR PANEL LAYOUT*

DRAWN BY:	TH
CHECKED BY:	GR
SCALE:	NONE
DATE:	3-29-18
PROJECT#:	03694-01-00
SHEET #:	2 OF 9

C:\Users\jess2013\Shared\Folders\Vehicle\CAO Design Documents\PROT PROJECTS\BASIC PROJECT START\005 Bill of Material.dwg

**STANTEC**  
**THIS PAGE ONLY**  
**NO EXCEPTION TAKEN**

**INTEGRATED CONTROLS**  
 15707 S. Merriette St  
 Olathe, KS 66062  
 Phone: (913) 782-9600  
 Fax: (913) 784-7829

THIS DRAWING CONTAINS MATERIAL AND/OR INFORMATION WHICH IS THE PROPERTY OF INTEGRATED CONTROLS, INC. AND SUPPLIED ONLY ON CONFIDENTIAL BASIS. NO TRANSMITTAL OR DISCLOSURE SHALL BE MADE TO ANY PERSON, FIRM, OR CORPORATION WITHOUT PRIOR WRITTEN APPROVAL OF INTEGRATED CONTROLS, INC.

ITEM	QTY	CATALOG	MFG	DESC	TAGS
1	2	1489-M1C200	ABB	20AMP, 1-POLE, M1C, CIRCUIT BREAKER, BULLETIN 1489 SERIES	CB104, CB111
2	6	15NK900001R0000	ABB	BAM3 END STOP	
3	157	15NK506010R0000	ABB	Z56 GREY 6mm SCREW CLAMP TERMINAL BLOCK	
4	3	15NK505910R0000	ABB	ES4 SCREW CLAMP TERMINAL BLOCK END COVER	
5	28	15NK506150R0000	ABB	Z56-PE 6mm SCREW CLAMP TERMINAL GROUNDING BLOCK	
6	1	15NK508960R0000	ABB	ES4-SF TERMINAL BLOCK END COVER	
7	1	MP1-10B	ABB	NON-ILLUMINATED PUSH BUTTON, FLUSH, MOMENTARY, 22mm, BLACK	PB264
8	4	MCBH-00	ABB	MODULAR HOLDER	LT126, PB118, SS126, PB264
9	2	MCB-10	ABB	CONTACT BLOCK, 1 N.O.	SS126, PB264
10	1	M2SS1-10B	ABB	2 POSITION SELECTOR SWITCH (CENTER TO RIGHT), MAINTAINED, 22mm, BLACK	SS126
11	18	15NK508410R0000	ABB	Z54-SF1 TERMINAL BLOCK FOR FUSES	FU237, FU287, FU305, FU310, FU315, FU320, FU325, FU329, FU333, FU337, FU355, FU359, FU363, FU367, FU371, FU376, FU381, FU385
12	16	0235003	LITTELFUSE	3.0 AMP FAST-ACTING CARTRIDGE FUSES, 5x20mm	FU305, FU310, FU315, FU320, FU325, FU329, FU333, FU337, FU355, FU359, FU363, FU367, FU371, FU376, FU381, FU385
13	1	MPET4-10R	ABB	NON-ILLUMINATED EMERGENCY STOP PUSH BUTTON, - TWIST RELEASE	PB118
14	1	MCB-01	ABB	CONTACT BLOCK (1 NC)	PB118
15	1	ML1-100W	ABB	PILOT LIGHT, MODULAR RANGE, WHITE LENS	LT126
16	1	MLBL-04W	ABB	120VAC WHITE LED PILOT LIGHT LAMP BLOCK	LT126
17	2	0235.500	LITTELFUSE	0.50 AMP FAST-ACTING CARTRIDGE FUSES, 5x20mm	FU237, FU287
18	1	15NK508418R0000	ABB	Z510-SF TERMINAL BLOCK FOR 6.3x32 FUSES	FU114
19	1	0325008	LITTELFUSE	8.0 AMP SLO-BLO FUSE	FU114
20	1	1SVR427032R0000	ABB	CP-E 24VDC/2.5A POWER SUPPLY	PW153
21	1	TDS1501SR150	ERICO	CRITEC TDS SURGE DIVERTER, U <sub>c</sub> 170V, I <sub>n</sub> 25kA, I <sub>max</sub> 50kA	SUP107
22	7	55.32.8.120.0040	FINDER	IND. PLUG-IN RELAY, DPDT 10A, 120VAC COIL, AGNI CONTACT, LOCKABLE TEST BUTTON & MECH. INDICATOR	CR304, CR309, CR314, CR319, CR324, CR328, CR358, CR362, CR366, CR370, CR375
23	7	94.04	FINDER	RELAY SOCKET, DIN-RAIL/PANEL MOUNT, SCREW, 14 PINS, 10A, 250V	CR328, CR332, CR358, CR362, CR366, CR370, CR375
24	1	A36P30	HOFFMAN	SUB-PANEL, 31.00x27.00	
25	1	A363012LP	HOFFMAN	CONTINUOUS HINGE W/CLAMPS, TYPE 12 ENCLOSURE	
26	1	KBMG-212D	KB ELECTRONICS	ULTRACOMPACT REGENERATIVE DRIVE	VFD111
27	1	BMX XBP 0800	MODICON	M340 RACK, 8 SLOT	
28	2	BMX DRA 0805	MODICON	M340 DISCRETE RELAY OUTPUT MODULE	PLC303, PLC353
29	5	BMX FTB 2010	MODICON	M340 MODULE 20-WAY TERMINAL BLOCK, SCREW CLAMP	PLC204, PLC254, PLC303, PLC353, PLC604
30	2	BMX DAI 1604	MODICON	M340 DISCRETE INPUT MODULE	PLC204, PLC254
31	1	BMX AMO 0802	MODICON	M340 ANALOG OUTPUT MODULE, 8-CH	PLC604
32	2	BMX AMI 0810	MODICON	M340 ANALOG INPUT MODULE, 8-CH	PLC404, PLC504
33	2	BMX FTB 2820	MODICON	M340 MODULE 28-WAY TERMINAL BLOCK, SPRING CLAMP	PLC404, PLC504
34	1	BMX PRA 0100	MODICON	X80 REMOTE I/O ADAPTER	DV158
35	1	BMX CPS 2010	MODICON	M340 POWER SUPPLY MODULE - 17W	DV158A

REV	DATE	DESCRIPTION	BY	APP'D
1	7-19-18	SUBMITTAL 1 COMMENTS	TH	DC

**TMWA MT. ROSE, NV**  
**TRIDET HS PACKAGE SYSTEM**  
**SLAVE CONTROL PANEL 1**  
**BILL OF MATERIAL**

DRAWN BY: TH  
 CHECKED BY: GR  
 SCALE: NONE  
 DATE: 3-29-18  
 PROJECT#: 03694-01-00  
 SHEET #:  
**3 OF 9**

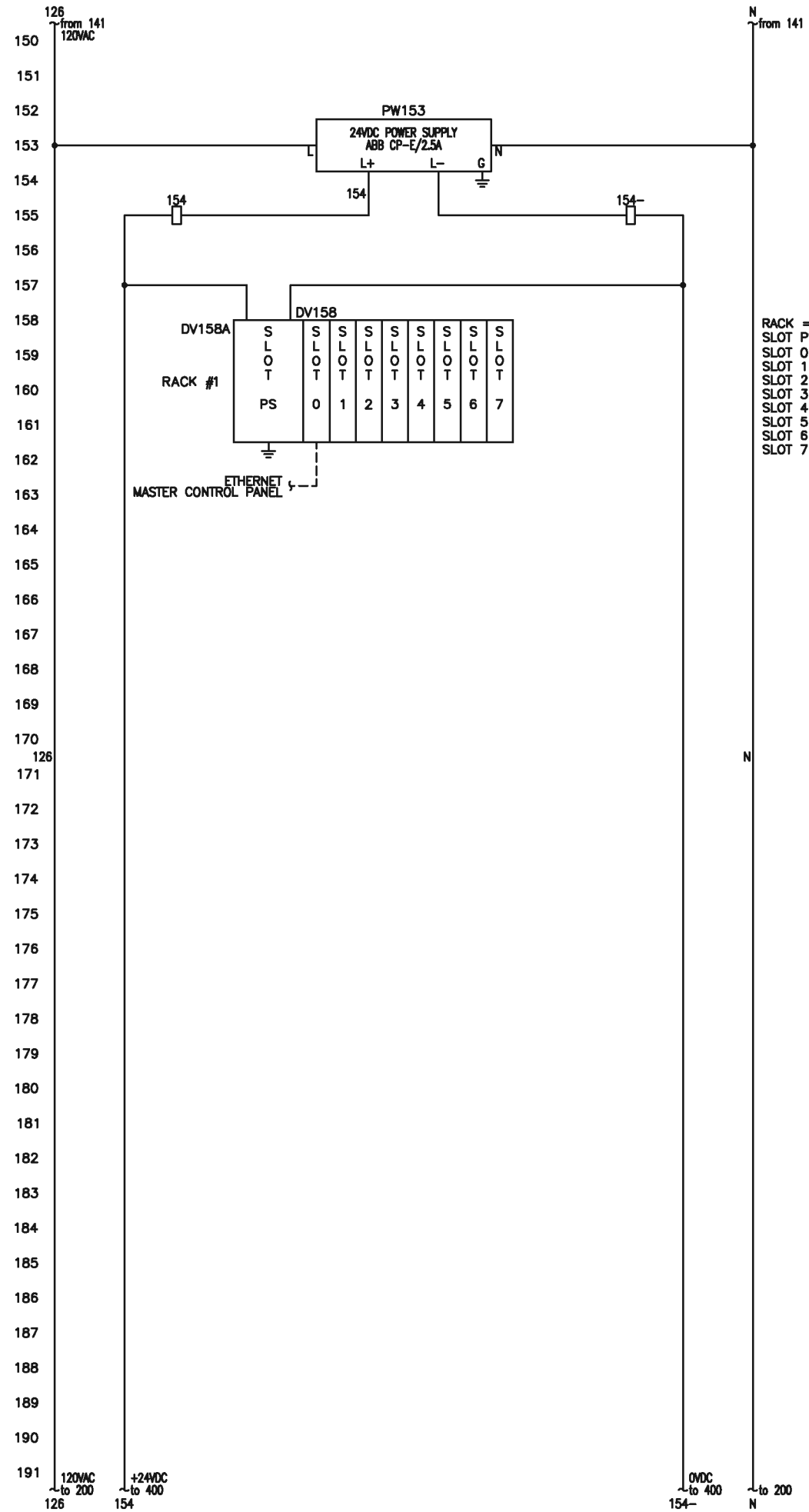
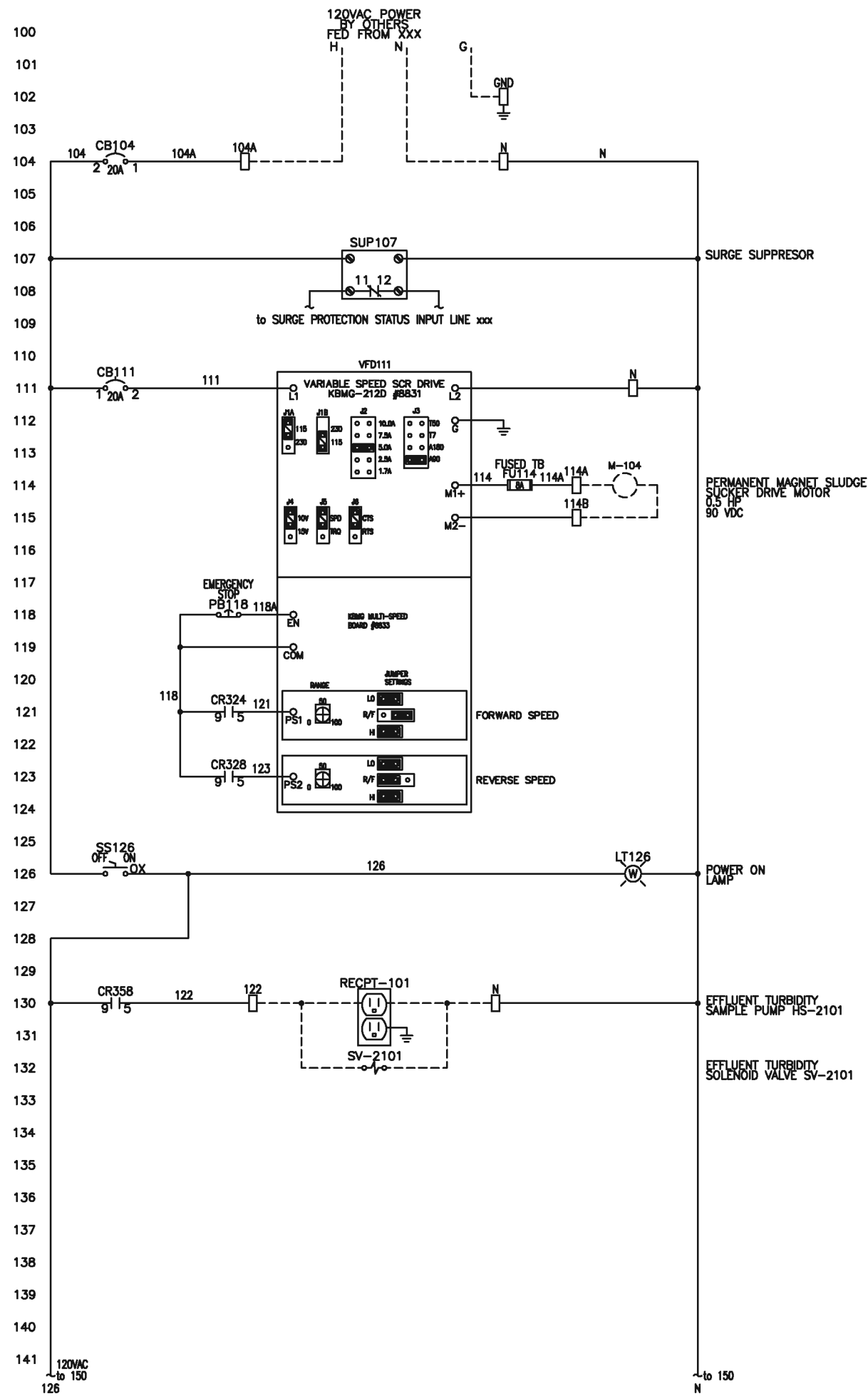

RACK = BMXXBP0800  
 SLOT PS = BMXCPS2010 POWER SUPPLY  
 SLOT 0 = BMXPRA0100 REMOTE I/O ADAPT.  
 SLOT 1 = BMXAMIO810 ANALOG IN  
 SLOT 2 = BMXAMIO810 ANALOG IN  
 SLOT 3 = BMXAMO0802 ANALOG OUT  
 SLOT 4 = BMXDAI1604 DISCRETE IN  
 SLOT 5 = BMXDAI1604 DISCRETE IN  
 SLOT 6 = BMXDRA0805 RELAY OUT  
 SLOT 7 = BMXDRA0805 RELAY OUT

**STANEC**  
**INTEGRATED CONTROLS, INC.**  
 15707 S. Mahaffie St.  
 Olathe, KS 66062  
 Phone: (913) 782-9600  
 Fax: (913) 764-7829

THIS DRAWING CONTAINS MATERIAL AND/OR INFORMATION WHICH IS THE PROPERTY OF INTEGRATED CONTROLS, INC. AND SUPPLIED ONLY ON CONFIDENTIAL BASIS. NO TRANSMITTAL OR DISCLOSURE SHALL BE MADE TO ANY PERSON, FIRM, OR CORPORATION WITHOUT PRIOR WRITTEN APPROVAL OF INTEGRATED CONTROLS, INC.

REV	DATE	DESCRIPTION	BY	APP'D
1	7-19-18	SUBMITTAL 1 COMMENTS	TH	

**TMWA MT. ROSE, NV  
 TRIDET HS PACKAGE SYSTEM  
 SLAVE CONTROL PANEL 1  
 SCHEMATICS**

DRAWN BY:	TH
CHECKED BY:	GR
SCALE:	NONE
DATE:	3-29-18
PROJECT#:	03694-01-00
SHEET #:	4 OF 9

\\ESS2013\Shared\_Folders\volatiles\CAD Design Documents\PROTOD PROJECTS\BASIC PROJECT START\300 Nama.dwg

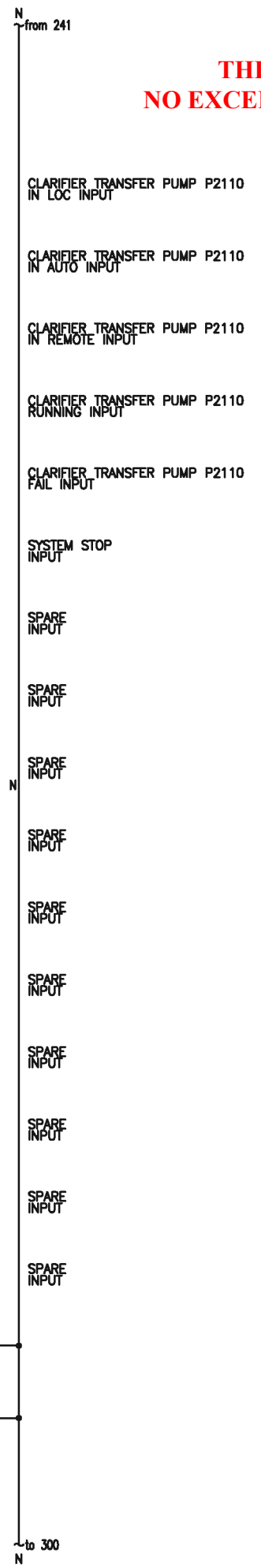
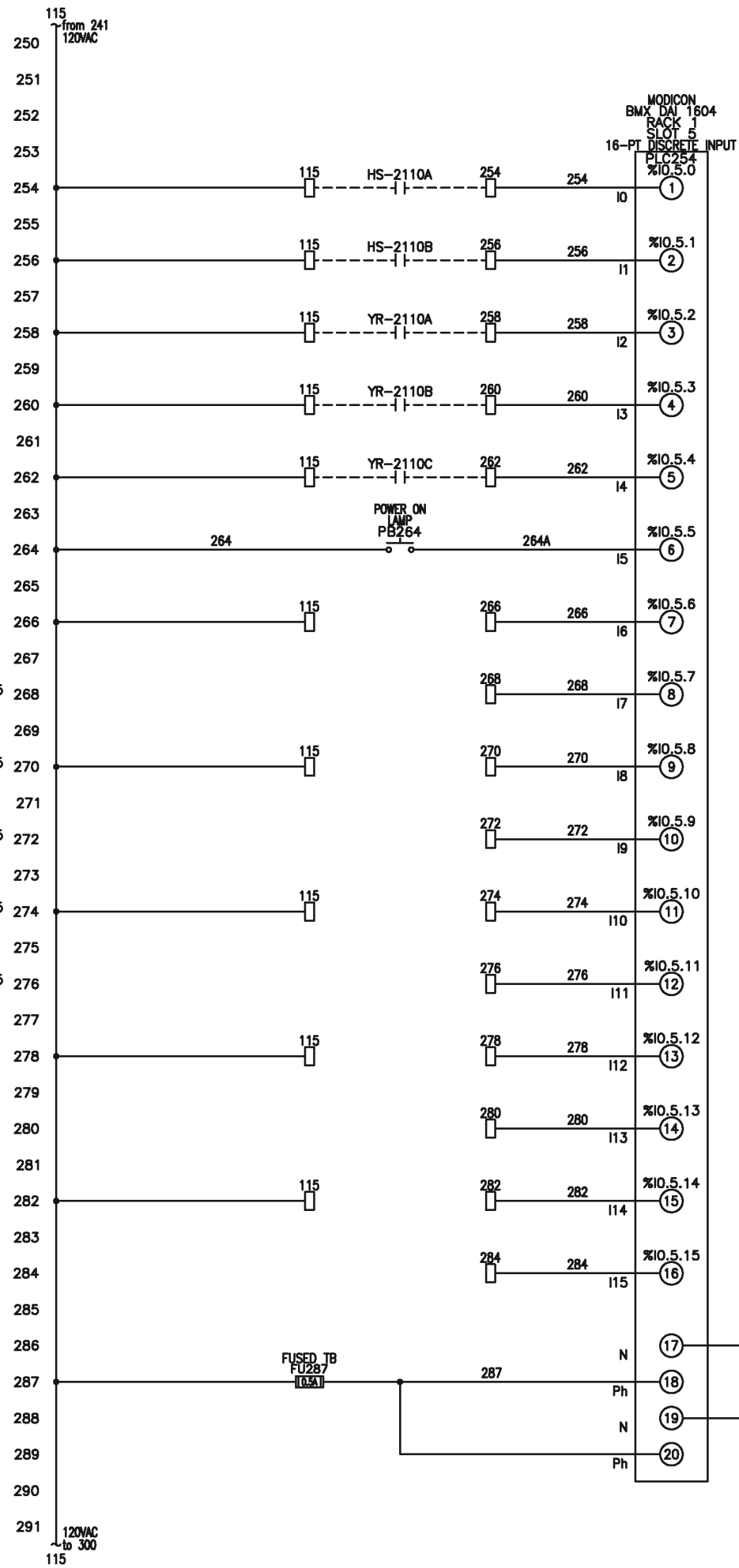
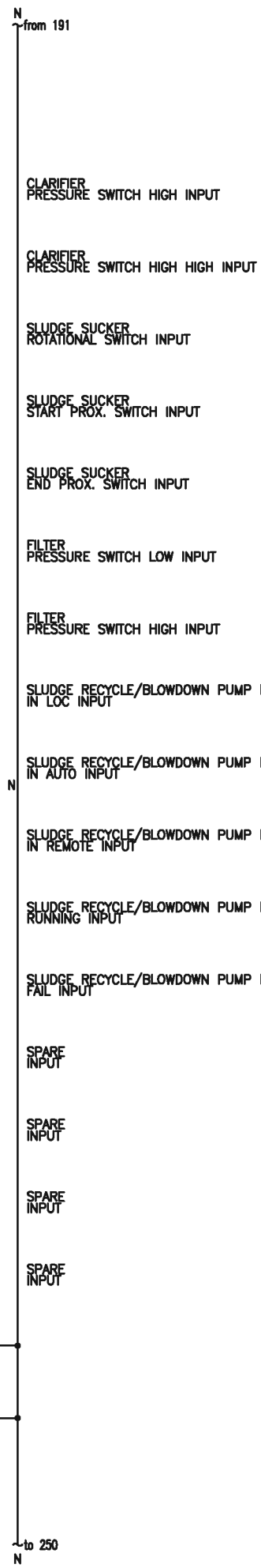
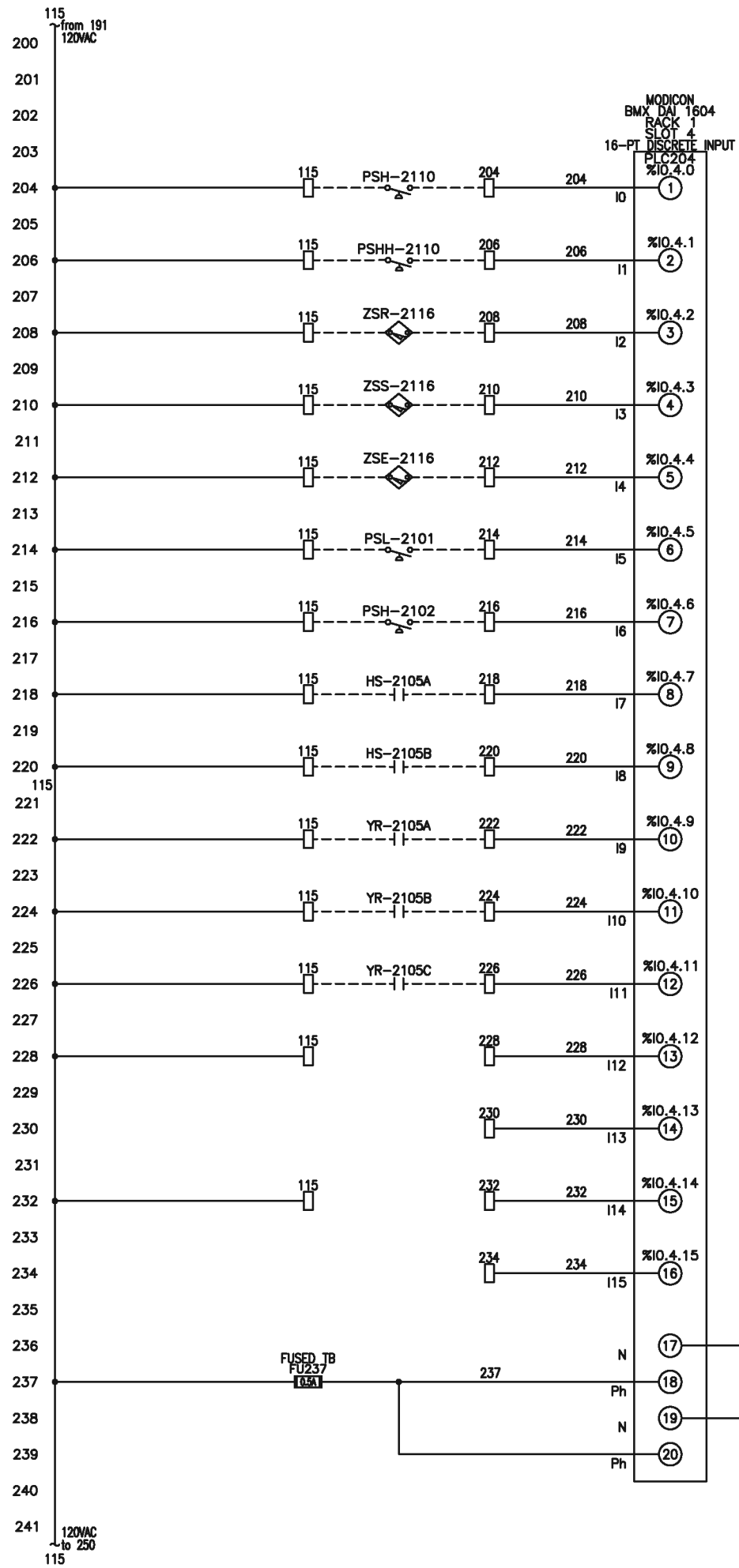

**STANTEC**  
**THIS PAGE ONLY**  
**NO EXCEPTION TAKEN**

**INTEGRATED CONTROLS**  
15707 S. Manterville St  
Olathe, KS 66062  
Phone: (913) 782-9600  
Fax: (913) 764-7829

THIS DRAWING CONTAINS MATERIAL AND/OR INFORMATION WHICH IS THE PROPERTY OF INTEGRATED CONTROLS, INC. AND SUPPLIED ONLY ON CONFIDENTIAL BASIS. NO TRANSMITTAL OR DISCLOSURE SHALL BE MADE TO ANY PERSON, FIRM, OR CORPORATION WITHOUT PRIOR WRITTEN APPROVAL OF INTEGRATED CONTROLS, INC.

REV	DATE	DESCRIPTION	BY	APP'D
1	7-19-18	SUBMITTAL 1 COMMENTS	TH	DC

**TMWA MT. ROSE, NV**  
**TRIDET HS PACKAGE SYSTEM**  
**SLAVE CONTROL PANEL 1**  
**SCHEMATICS**

DRAWN BY:	TH
CHECKED BY:	GR
SCALE:	NONE
DATE:	3-29-18
PROJECT#	03694-01-00
SHEET #	

\\ESS2013\Shared Folders\volatiles\CAD Design Documents\PROJECTS\BASIC PROJECT STARTY\400 Nama.dwg

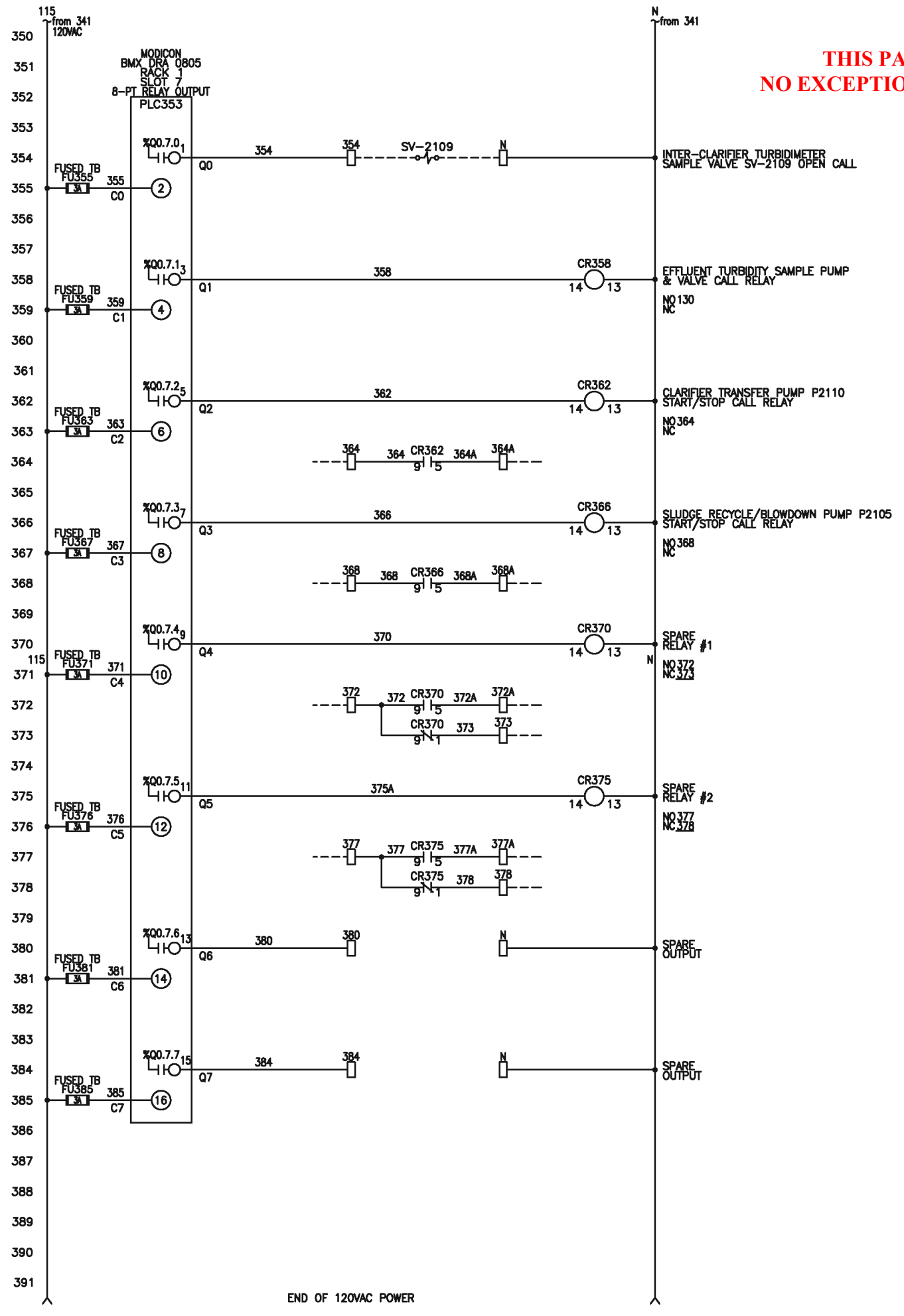
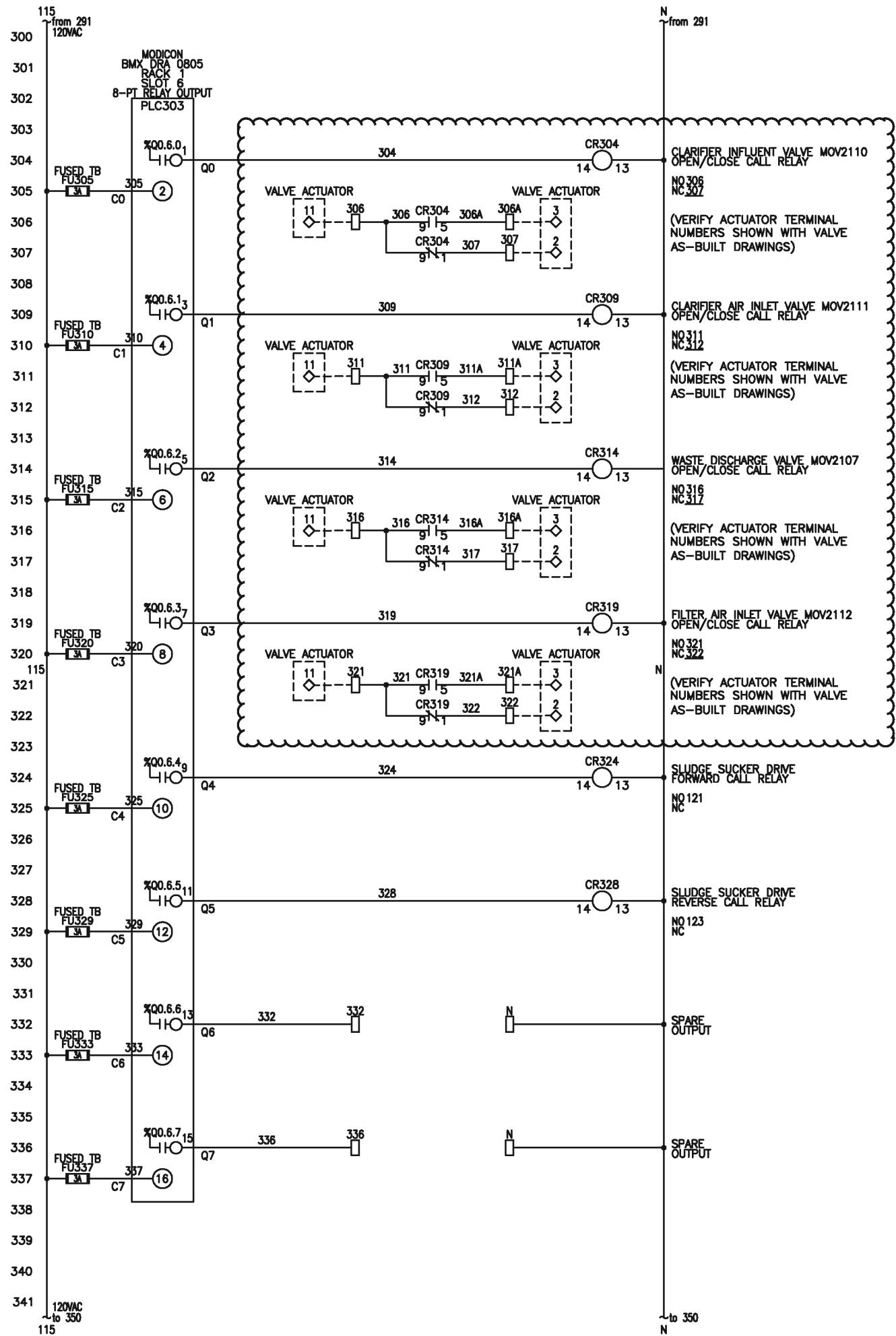

**STANTEC**  
**THIS PAGE ONLY**  
**NO EXCEPTION TAKEN**

INTEGRATED CONTROLS  
 15707 S. Manchester St  
 Olathe, KS 66062  
 Phone: (913) 782-9600  
 Fax: (913) 764-7829

THIS DRAWING CONTAINS MATERIAL AND/OR INFORMATION WHICH IS THE PROPERTY OF INTEGRATED CONTROLS, INC. AND SUPPLIED ONLY ON CONFIDENTIAL BASIS. NO TRANSMITTAL OR DISCLOSURE SHALL BE MADE TO ANY PERSON, FIRM, OR CORPORATION WITHOUT PRIOR WRITTEN APPROVAL OF INTEGRATED CONTROLS, INC.

REV	DATE	DESCRIPTION	BY	APP'D
1	7-19-18	SUBMITTAL 1 COMMENTS	TH	DC

**TMWA MT. ROSE, NV**  
**TRIDET HS PACKAGE SYSTEM**  
**SLAVE CONTROL PANEL 1**  
**SCHEMATICS**

DRAWN BY:	TH
CHECKED BY:	GR
SCALE:	NONE
DATE:	3-29-18
PROJECT#:	03694-01-00
SHEET #:	6 OF 9

END OF 120VAC POWER

c:\msdcs\shared folders\volatiles\cad design documents\project basic project start\500 Name.dwg

400 154+ from 191 +24VDC  
 401  
 402  
 403  
 404  
 405  
 406  
 407  
 408  
 409  
 410  
 411  
 412  
 413  
 414  
 415  
 416  
 417  
 418  
 419  
 420 154+  
 421  
 422  
 423  
 424  
 425  
 426  
 427  
 428  
 429  
 430  
 431  
 432  
 433  
 434  
 435  
 436  
 437  
 438  
 439  
 440  
 441 +24VDC to 450 154+

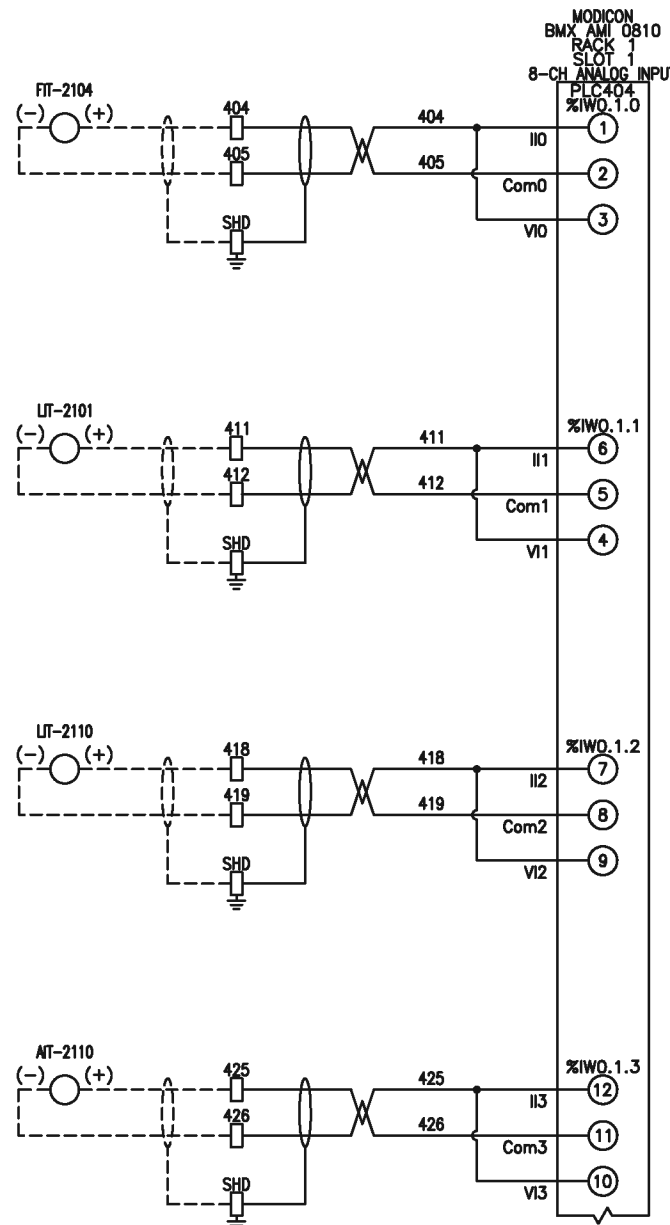

154- from 191 0VDC  
 INFLUENT FLOW INPUT  
 COLLECTOR LEVEL INPUT  
 FILTER LEVEL INPUT  
 154-  
 INTER-CLARIFIER TURBIDIMETER INPUT  
 0VDC to 450 154-

450 154+ from 441 +24VDC  
 451  
 452  
 453  
 454  
 455  
 456  
 457  
 458  
 459  
 460  
 461  
 462  
 463  
 464  
 465  
 466  
 467  
 468  
 469  
 470 154+  
 471  
 472  
 473  
 474  
 475  
 476  
 477  
 478  
 479  
 480  
 481  
 482  
 483  
 484  
 485  
 486  
 487  
 488  
 489  
 490  
 491 +24VDC to 500 154+

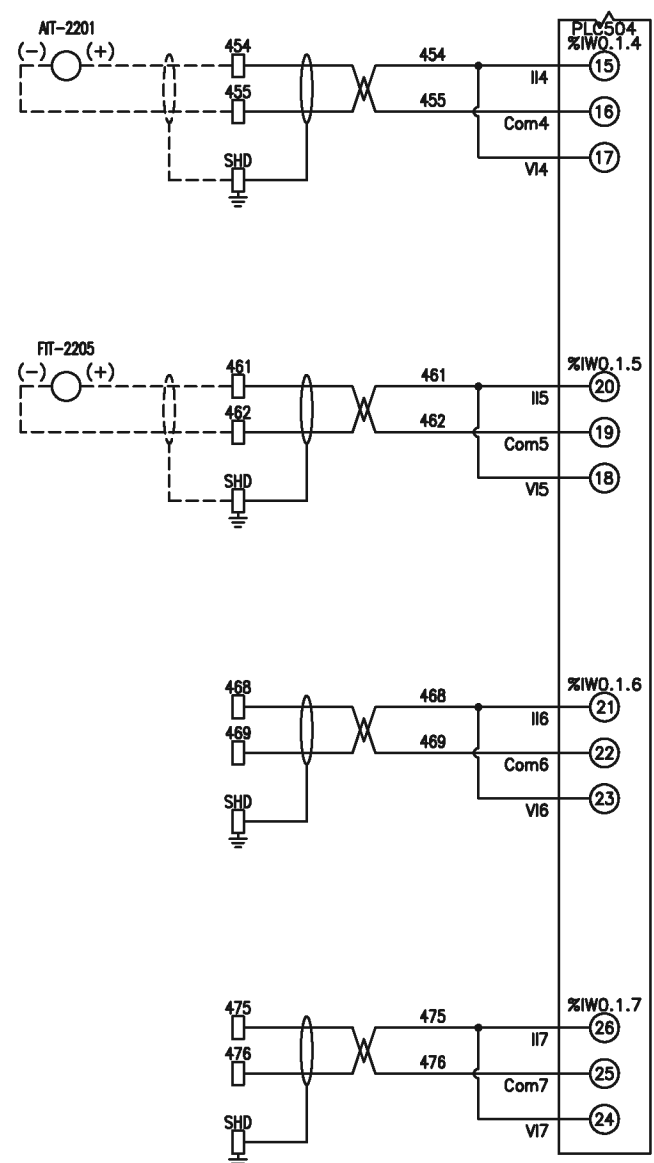

154- from 441 0VDC  
 EFFLUENT TURBIDIMETER INPUT  
 SLUDGE RECYCLE FLOW INPUT  
 154-  
 SPARE INPUT  
 0VDC to 500 154-

**STANTEC**  
 THIS PAGE ONLY  
 NO EXCEPTION TAKEN

INTEGRATED CONTROLS  
 15707 S. Manterville St  
 Olathe, KS 66062  
 Phone: (913) 782-9600  
 Fax: (913) 764-7829

THIS DRAWING CONTAINS MATERIAL AND/OR INFORMATION WHICH IS THE PROPERTY OF INTEGRATED CONTROLS, INC. AND SUPPLIED ONLY ON CONFIDENTIAL BASIS. NO TRANSMITTAL OR DISCLOSURE SHALL BE MADE TO ANY PERSON, FIRM, OR CORPORATION WITHOUT PRIOR WRITTEN APPROVAL OF INTEGRATED CONTROLS, INC.

REV	DATE	DESCRIPTION	BY	APP'D
1	7-19-18	SUBMITTAL 1 COMMENTS	TH	DC

**TMWA MT. ROSE, NV  
 TRIDET HS PACKAGE SYSTEM  
 SLAVE CONTROL PANEL 1  
 SCHEMATICS**

DRAWN BY:	TH
CHECKED BY:	GR
SCALE:	NONE
DATE:	3-29-18
PROJECT#	03694-01-00
SHEET #	7 OF 9

\\ESS2013\Shared Folders\volatiles\CAD Design Documents\PROJECTS\BASIC PROJECT START\500 Name.dwg

500 154+  
from 491  
+24VDC  
501  
502  
503  
504  
505  
506  
507  
508  
509  
510  
511  
512  
513  
514  
515  
516  
517  
518  
519  
520 154+  
521 154+  
522  
523  
524  
525  
526  
527  
528  
529  
530  
531  
532  
533  
534  
535  
536  
537  
538  
539  
540  
541 +24VDC  
to 550  
154+

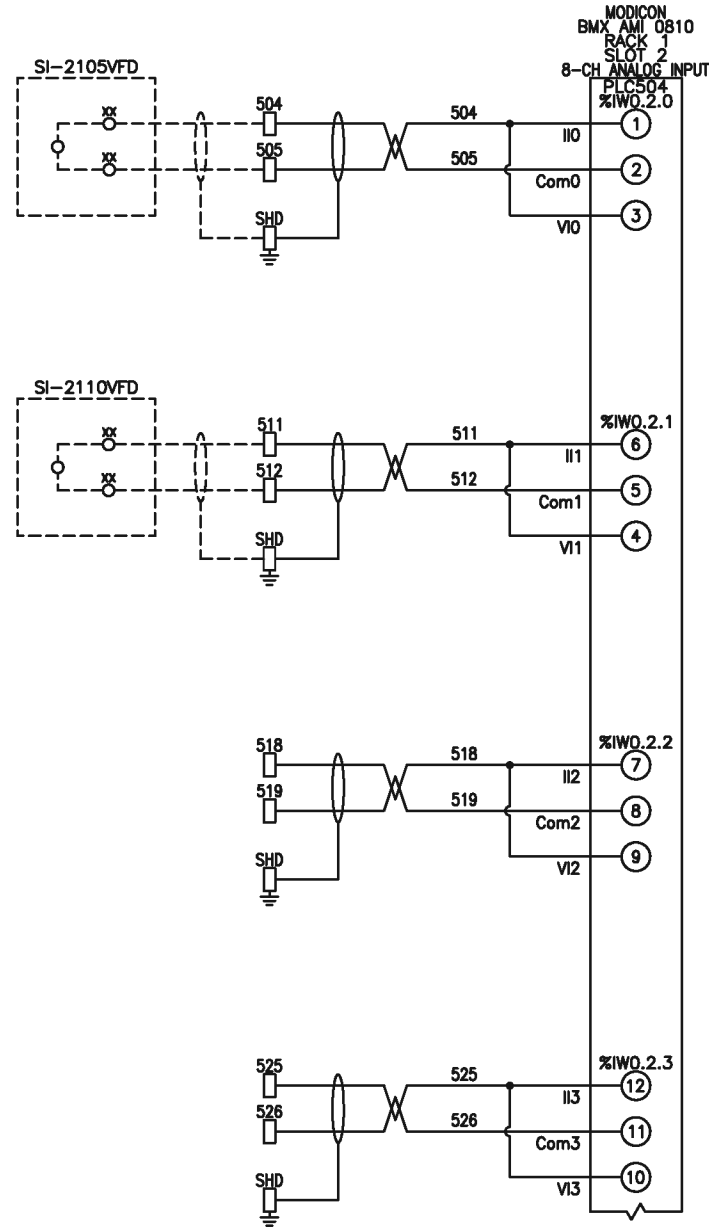

154-  
from 491  
OVDC  
154-  
OVDC  
to 550  
154-  
OVDC  
to 600  
154+

SLUDGE RECYCLE/BLOWDOWN PUMP P2105  
SPEED FEEDBACK INPUT

CLARIFIER TRANSFER PUMP P2110  
SPEED FEEDBACK INPUT

SPARE INPUT

SPARE INPUT

550 154+  
from 541  
+24VDC  
551  
552  
553  
554  
555  
556  
557  
558  
559  
560  
561  
562  
563  
564  
565  
566  
567  
568  
569  
570 154+  
571 154+  
572  
573  
574  
575  
576  
577  
578  
579  
580  
581  
582  
583  
584  
585  
586  
587  
588  
589  
590  
591 +24VDC  
to 600  
154+

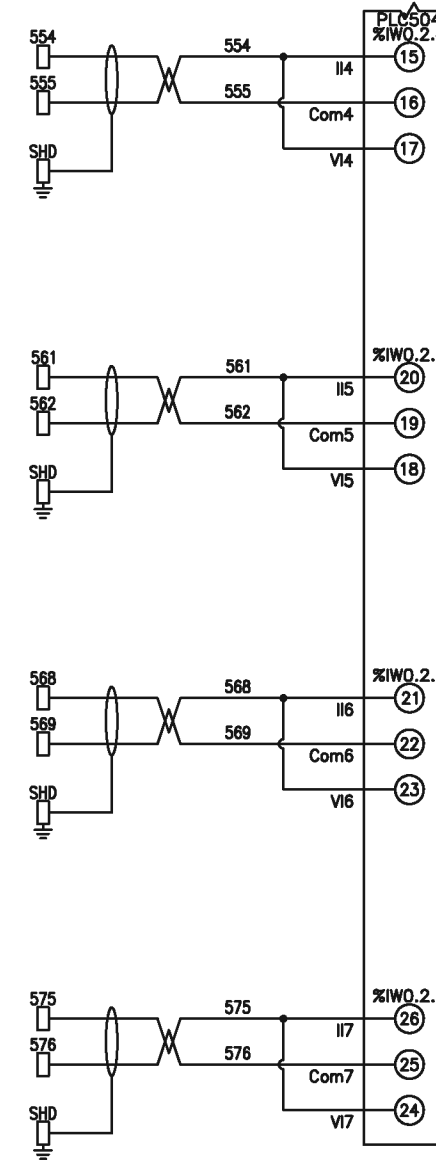

154-  
from 541  
OVDC  
154-  
OVDC  
to 600  
154-

SPARE INPUT

SPARE INPUT

SPARE INPUT

SPARE INPUT

**STANTEC**  
**THIS PAGE ONLY**  
**NO EXCEPTION TAKEN**  
INTEGRATED CONTROLS  
15707 S. Manterville St  
Olathe, KS 66062  
Phone: (913) 782-9600  
Fax: (913) 764-7829

THIS DRAWING CONTAINS MATERIAL AND/OR INFORMATION WHICH IS THE PROPERTY OF INTEGRATED CONTROLS, INC. AND SUPPLIED ONLY ON CONFIDENTIAL BASIS. NO TRANSMITTAL OR DISCLOSURE SHALL BE MADE TO ANY PERSON, FIRM, OR CORPORATION WITHOUT PRIOR WRITTEN APPROVAL OF INTEGRATED CONTROLS, INC.

REV	DATE	DESCRIPTION	BY	APP'D
1	7-19-18	SUBMITTAL 1 COMMENTS	TH	DC

**TMWA MT. ROSE, NV  
TRIDET HS PACKAGE SYSTEM  
SLAVE CONTROL PANEL 1  
SCHEMATICS**

DRAWN BY:	TH
CHECKED BY:	GR
SCALE:	NONE
DATE:	3-29-18
PROJECT#:	03694-01-00
SHEET #:	

c:\p1\m1\13\Shared Folders\CAD Documents\PROJECTS\BASIC PROJECT START\600 Name.dwg

600 154+  
601 from 591  
602 +24VDC  
603  
604  
605  
606  
607  
608  
609  
610  
611  
612  
613  
614  
615  
616  
617  
618  
619  
620  
621 154+  
622  
623  
624  
625  
626  
627  
628  
629  
630  
631  
632  
633  
634  
635  
636  
637  
638  
639  
640  
641 +24VDC  
154+  
to 650

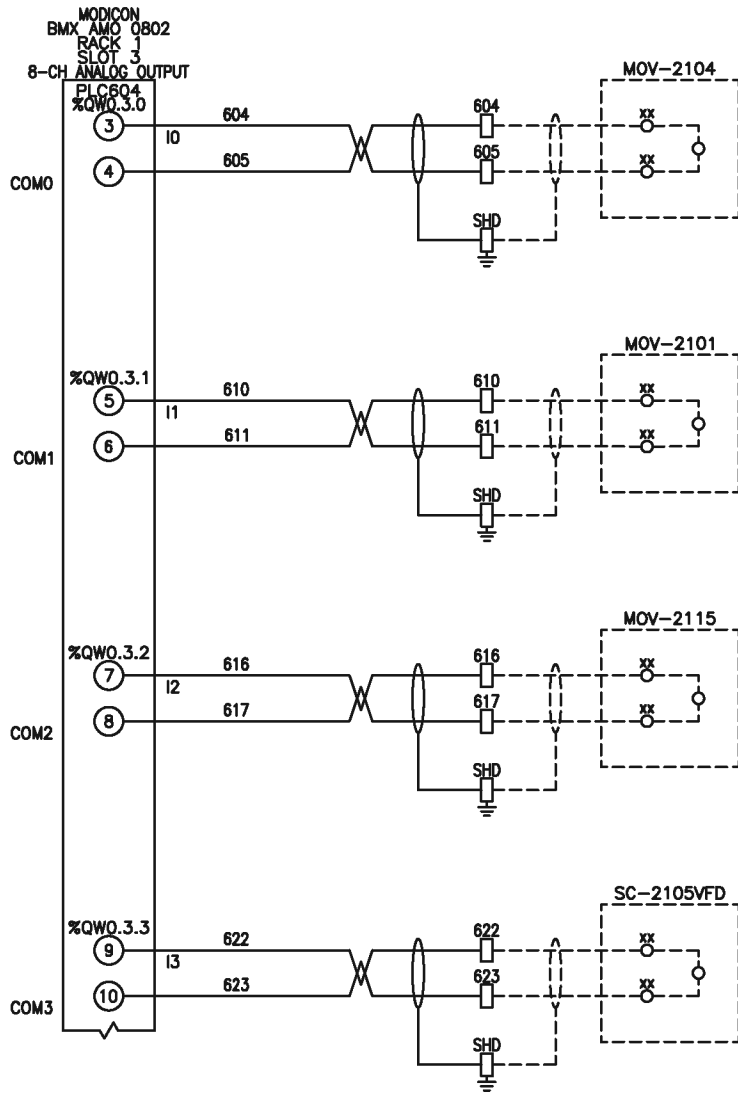

154- from 591  
OVDC  
154-  
OVDC to 650  
154+

TUBE CLARIFIER INFLUENT VALVE MOV-2104  
POSITION CMD OUTPUT

EFFLUENT EFFLUENT VALVE MOV-2101  
POSITION CMD OUTPUT

FILTER TO WASTE VALVE MOV-2115  
POSITION CMD OUTPUT

SLUDGE RECYCLE/BLOWDOWN PUMP P2105  
SPEED CONTROL OUTPUT

154+ from 641  
+24VDC  
650  
651  
652  
653  
654  
655  
656  
657  
658  
659  
660  
661  
662  
663  
664  
665  
666  
667  
668  
669  
670  
671 154+  
672  
673  
674  
675  
676  
677  
678  
679  
680  
681  
682  
683  
684  
685  
686  
687  
688  
689  
690  
691

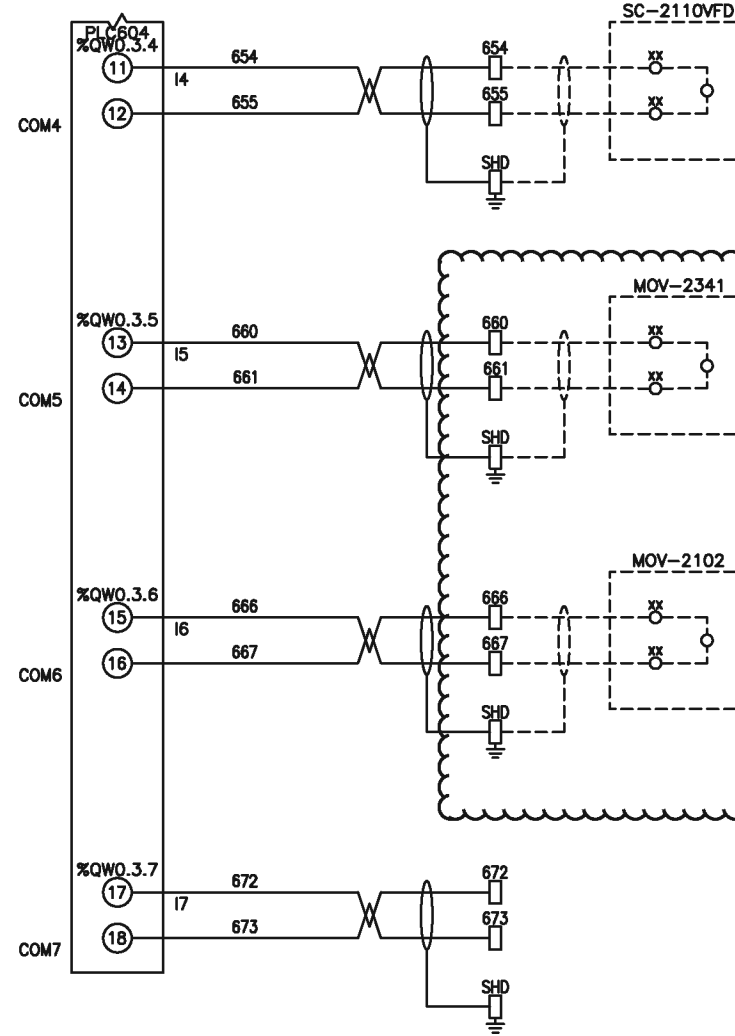

154- from 641  
OVDC  
154-

TRANSFER PUMP P2110  
SPEED CONTROL OUTPUT

FLUSH MAKEUP VALVE MOV-2341  
POSITION CMD OUTPUT

FILTER BACKWASH VALVE MOV-2102  
POSITION CMD OUTPUT

SPARE  
OUTPUT

END OF 24VDC POWER  
END OF ELECTRICAL DRAWINGS

THIS PAGE ONLY  
NO EXCEPTION TAKEN

**STANTEC**  
INTEGRATED CONTROLS

15707 S. Manhatta St  
Olathe, KS 66062  
Phone: (913) 782-9600  
Fax: (913) 764-7829

THIS DRAWING CONTAINS MATERIAL AND/OR INFORMATION WHICH IS THE PROPERTY OF INTEGRATED CONTROLS, INC. AND SUPPLIED ONLY ON CONFIDENTIAL BASIS. NO TRANSMITTAL OR DISCLOSURE SHALL BE MADE TO ANY PERSON, FIRM, OR CORPORATION WITHOUT PRIOR WRITTEN APPROVAL OF INTEGRATED CONTROLS, INC.

REV	DATE	DESCRIPTION	BY	APP'D
1	7-19-18	SUBMITTAL 1 COMMENTS	TH	DC

**TMWA MT. ROSE, NV  
TRIDET HS PACKAGE SYSTEM  
SLAVE CONTROL PANEL 1  
SCHEMATICS**

DRAWN BY:	TH
CHECKED BY:	GR
SCALE:	NONE
DATE:	3-29-18
PROJECT#:	03694-01-00
SHEET #:	9 OF 9

**STANTEC**  
**THIS PAGE ONLY**  
**NO EXCEPTION TAKEN**

SUBMITTAL  
Do Not Use  
For Installation

This Page was left blank intentionally.

**STANTEC**  
**THIS PAGE ONLY**  
**NO EXCEPTION TAKEN**

SUBMITTAL  
Do Not Use  
For Installation

# SECTION 4

**Slave CP 2 Drawings**

**STANTEC**  
**THIS PAGE ONLY**  
**NO EXCEPTION TAKEN**

SUBMITTAL  
Do Not Use  
For Installation

This Page was left blank intentionally.

# TMWA MT. ROSE, NV TRIDENT HS PACKAGE SYSTEM SLAVE CONTROL PANEL 2

**STANTEC**  
**THIS PAGE ONLY**  
**NO EXCEPTION TAKEN**

INTEGRATED CONTROLS  
15707 S. Mohrville St  
Olathe, KS 66062  
Phone: (913) 782-9600  
Fax: (913) 784-7829

THIS DRAWING CONTAINS MATERIAL AND/OR INFORMATION WHICH IS THE PROPERTY OF INTEGRATED CONTROLS, INC. AND SUPPLIED ONLY ON CONFIDENTIAL BASIS. NO TRANSMITTAL OR DISCLOSURE SHALL BE MADE TO ANY PERSON, FIRM, OR CORPORATION WITHOUT PRIOR WRITTEN APPROVAL OF INTEGRATED CONTROLS, INC.

REV	DATE	DESCRIPTION	BY	APP'D
1	7-19-18	1 COMMENTS	TH	DC

TMWA MT. ROSE, NV  
TRIDENT HS PACKAGE SYSTEM  
SLAVE CONTROL PANEL 2  
COVER SHEET

DRAWN BY:	TH
CHECKED BY:	GR
SCALE:	NONE
DATE:	3-29-18
PROJECT#:	03694-01-00
SHEET #:	1 OF 9

ELECTRICAL SYMBOLS	CONTROL PANEL SPECIFICATIONS
<p><b>TERMINAL BLOCKS:</b> (PANEL MOUNTED) (REMOTE MOUNTED) </p> <p><b>CIRCUIT BREAKER:</b> CB1 20AMPS <b>DISCONNECT SWITCH:</b> DS1 100AMPS <b>FUSE:</b> FU1 10A <b>GROUND:</b> </p> <p><b>COILS:</b> Control Relays, Timers, Motor Starters, etc. CR1 (Control Relay), TD1 (Timer Relay), MS1 (Motor Starter)</p> <p><b>CONTACTS:</b> Control Relays, Timers, Motor Starters, etc. CR1 (Local), CR1 (Remote), OL1 (Overload Relay)</p> <p><b>SWITCHES AND PUSHBUTTONS:</b> (SELECTOR) SS1, (N.O. PUSHBUTTON) PB1, (N.C. PUSHBUTTON) PB1, (MECHANICAL INTERLOCK)</p> <p><b>WIRING:</b> CONNECTION (LOCAL WIRING), NO CONNECTION, (REMOTE WIRING)</p> <p><b>Pressure Switch:</b> PS1 (N.O.), PS1 (N.C.) <b>Flow Switch:</b> FS1 (N.O.), FS1 (N.C.) <b>Float Switch:</b> FLT1 (N.O.), FLT1 (N.C.) <b>Temperature Switch:</b> TAS1 (N.O.), TAS1 (N.C.) <b>Limit Switch:</b> LS1 (N.O.), LS1 (N.O. HELD CLOSED), LS1 (N.C.), LS1 (N.C. HELD OPEN)</p> <p><b>Solenoid Valves:</b> SOL1 (Local), SOL1 (Remote) <b>Heater Coil:</b> HC1 <b>Indication (Pilot) Lamps:</b> LT1 (Green), LT1 (Red), LT1 (Blue), LT1 (White), LT1 (Amber) <b>Resistor:</b> R1 OHMS <b>Diodes:</b> D1, D1 <b>Horn:</b> AH1 <b>Transformer:</b> XF1 <b>Suppressor:</b> SUP1</p> <p><b>Electrical Outlet 120VAC OR 220VAC:</b> RECEPT1, RECEPT1</p>	<p><b>CONTROL PANEL UL LISTED:</b> <input type="checkbox"/> NOT LISTED <input checked="" type="checkbox"/> 508A (INDUSTRIAL CONTROL PANELS) <input type="checkbox"/> 698A (INDUSTRIAL CONTROL PANELS RELATING TO HAZARDOUS (CLASSIFIED) LOCATIONS)</p> <p><b>WIRE TYPE &amp; SIZE:</b> POWER: <input checked="" type="checkbox"/> MTW #14 <input type="checkbox"/> THHN # <input type="checkbox"/> SIS # <input type="checkbox"/> OTHER: CONTROL: <input checked="" type="checkbox"/> MTW #16 <input type="checkbox"/> THHN # <input type="checkbox"/> SIS # <input type="checkbox"/> OTHER: ANALOG SIGNAL: <input checked="" type="checkbox"/> SHIELDED #18</p> <p><b>SPECIAL WIRE ENDS:</b> <input checked="" type="checkbox"/> NONE <input type="checkbox"/> TIN <input type="checkbox"/> FERRULE <input type="checkbox"/> RING TERMINALS <input type="checkbox"/> OTHER:</p> <p><b>COLOR CODING:</b> AC HOT: BLACK AC NEUTRAL: WHITE AC SWITCHED (CONTROL): RED DC+: BLUE DC-: BLUE W/WHITE STRIPE DRY CONTACTS (FOREIGN VOLTAGE): YELLOW GROUND: GREEN</p> <p><b>WIRE TAGGING:</b> <input type="checkbox"/> NONE <input checked="" type="checkbox"/> SLEEVE (NON-SHRINK) <input type="checkbox"/> SLEEVE (SHRINK) <input type="checkbox"/> WRAP AROUND</p> <p><b>EQUIPMENT TAGGING:</b> ENGRAVING COLOR: <input checked="" type="checkbox"/> WHITE TEXT ON BLACK <input type="checkbox"/> BLACK TEXT ON WHITE <input type="checkbox"/> OTHER: PANEL DOOR: <input checked="" type="checkbox"/> ENGRAVED PHENOLIC (ADHESIVE MOUNT) <input type="checkbox"/> ENGRAVED PHENOLIC (SCREW MOUNT) BACK PANEL TYPE: <input checked="" type="checkbox"/> P-TOUCH (LAMINATED) <input type="checkbox"/> OTHER: DIN RAIL: <input checked="" type="checkbox"/> STEEL <input type="checkbox"/> ALUMINUM <input type="checkbox"/> COPPER</p>
<p><b>NEEDLE VALVE:</b> GVA1 <b>BULKHEAD:</b> </p>	<p><b>NOTES:</b> 1. ALL DEVICES SHOWN REMOTELY MOUNTED OR WIRED REMOTELY ARE PROVIDED, MOUNTED AND CONNECTED BY OTHERS UNLESS SPECIFICALLY IDENTIFIED AS BEING SUPPLIED BY INTEGRATED CONTROLS, INC (ICI). DEVICES SPECIFICALLY IDENTIFIED AS BEING SUPPLIED BY ICI BUT ARE NOT MOUNTED IN THE CONTROL PANEL ARE MOUNTED AND CONNECTED BY OTHERS. 2. ALL ANALOG SIGNALS, PANEL INTERNAL WIRING OR FIELD WIRING, BOTH CURRENT AND VOLTAGE TYPES ARE TO BE WIRED IN BRAID SHIELDED TWISTED PAIR MULTI-CONDUCTOR CABLE. FIELD ANALOG WIRING IS NOT TO BE INSTALLED IN SAME CONDUIT AS AC CONTROL WIRING OR POWER WIRING OF ANY KIND. 3. INSTALLATION OF EQUIPMENT SHOULD BE MADE WITH ICI DIAGRAMS MARKED "INSTALLATION DRAWINGS" WHICH WILL REFLECT THE CORRECT ELECTRICAL/PNEUMATIC CONNECTION POINTS. 4. (120VAC SYSTEMS ONLY) WHERE MORE THAN ONE VOLTAGE SUPPLY IS REQUIRED AT ONE CONTROL PANEL, ONLY ONE PHASE SHOULD BE USED. THIS WILL ENSURE THAT 120VAC IS THE HIGHEST POTENTIAL AVAILABLE IN THE PANEL.</p>

C:\Users\mz\Shared Folders\Volante\CAD Design Documents\PROJECTS\BASIC PROJECT START\001 Cover Sheet.dwg

C:\ES2013\Shared\_Folders\volatile\CAD Design Documents\PROTD PROJECTS\BASIC PROJECT START\004 Interior Panel Layout.dwg

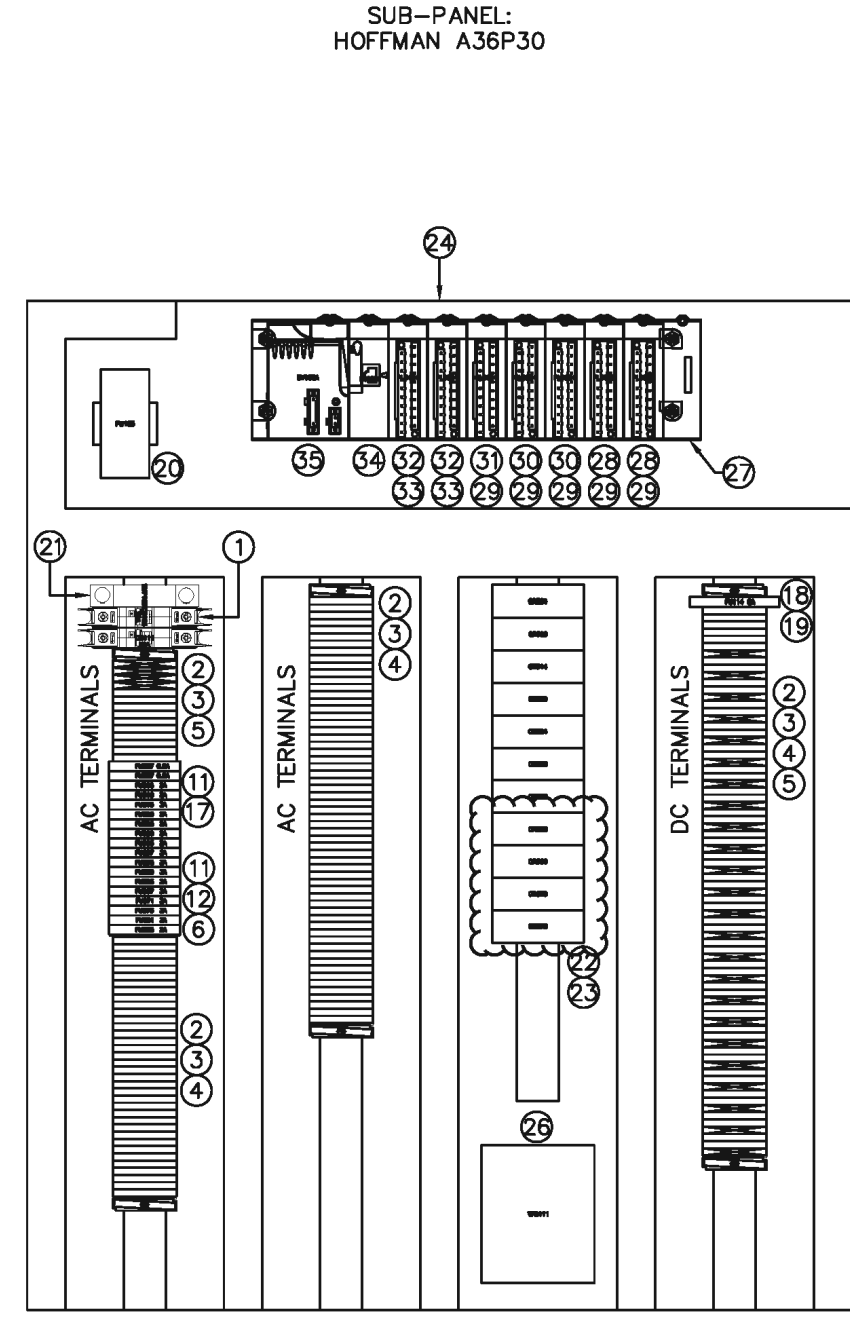
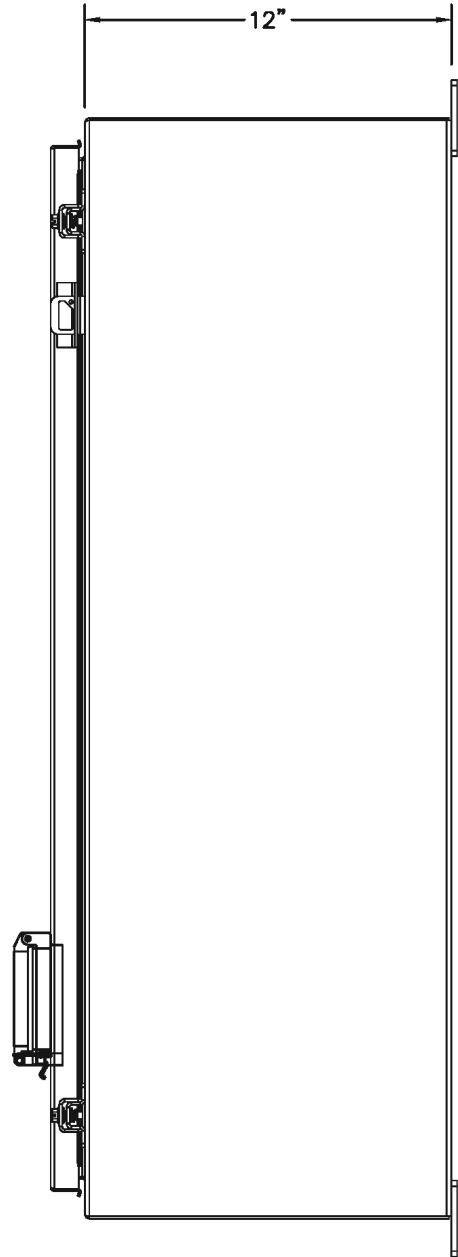
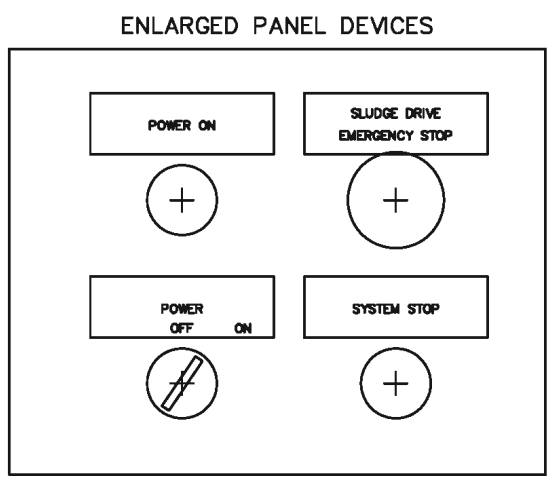
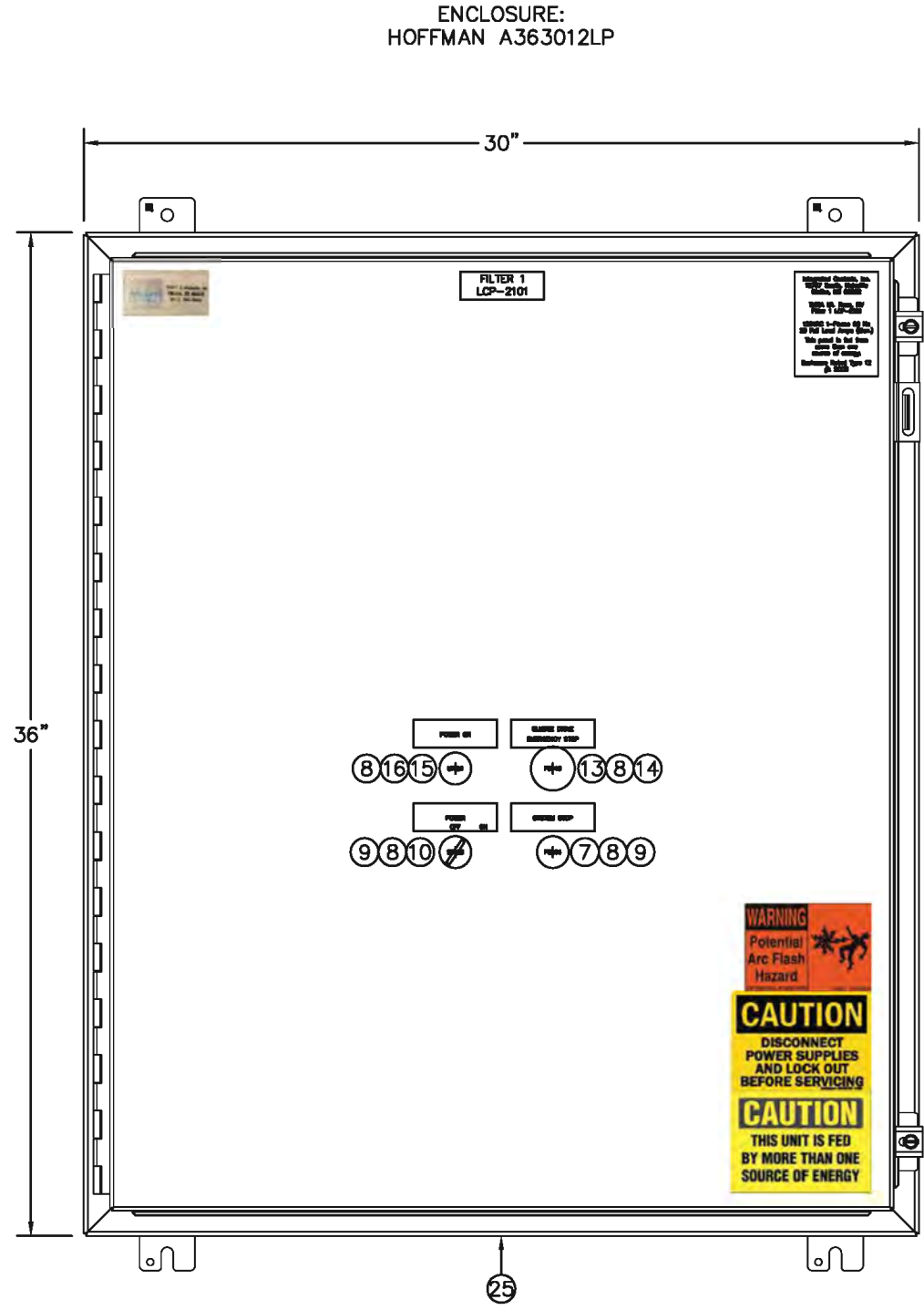

**STANTEC**  
**THIS PAGE ONLY**  
**NO EXCEPTION TAKEN**

**INTEGRATED CONTROLS**

15707 S. Monette St  
Olathe, KS 66062  
Phone: (913) 782-9600  
Fax: (913) 784-7829

THIS DRAWING CONTAINS MATERIAL AND/OR INFORMATION WHICH IS THE PROPERTY OF INTEGRATED CONTROLS, INC. AND SUPPLIED ONLY ON CONFIDENTIAL BASIS. NO TRANSMITTAL OR DISCLOSURE SHALL BE MADE TO ANY PERSON, FIRM, OR CORPORATION WITHOUT PRIOR WRITTEN APPROVAL OF INTEGRATED CONTROLS, INC.

REV	DATE	DESCRIPTION	BY	APP'D
1	7-19-18	SUBMITTAL 1 COMMENTS	TH	DC

*TMWA MT. ROSE, NV*  
*TRIDET HS PACKAGE SYSTEM*  
*SLAVE CONTROL PANEL 2*  
*INTERIOR PANEL LAYOUT*

DRAWN BY: TH  
CHECKED BY: GR  
SCALE: NONE  
DATE: 3-29-18  
PROJECT#: 03694-01-00  
SHEET #:  
**2 OF 9**

C:\ES2013\Shared Folders\Vehicle\CAO Design Documents\PROTOD PROJECTS\BASIC PROJECT START\005 Bill of Material.dwg

ITEM	QTY	CATALOG	MFG	DESC	TAGS
1	2	1489-M1C200	ABB	20AMP, 1-POLE, M1C, CIRCUIT BREAKER, BULLETIN 1489 SERIES	CB104, CB111
2	6	15NK900001R0000	ABB	BAM3 END STOP	
3	157	15NK506010R0000	ABB	ZS6 GREY 6mm SCREW CLAMP TERMINAL BLOCK	
4	3	15NK505910R0000	ABB	ES4 SCREW CLAMP TERMINAL BLOCK END COVER	
5	28	15NK506150R0000	ABB	ZS6-PE 6mm SCREW CLAMP TERMINAL GROUNDING BLOCK	
6	1	15NK508960R0000	ABB	ES4-SF TERMINAL BLDCK END COVER	
7	1	MP1-10B	ABB	NON-ILLUMINATED PUSH BUTTON, FLUSH, MOMENTARY, 22mm, BLACK	PB264
8	4	MCBH-00	ABB	MODULAR HOLDER	LT126, PB118, SS126, PB264
9	2	MCB-10	ABB	CONTACT BLOCK, 1 N.O.	SS126, PB264
10	1	M2SS1-10B	ABB	2 POSITION SELECTOR SWITCH (CENTER TO RIGHT), MAINTAINED, 22mm, BLACK	SS126
11	18	15NK508410R0000	ABB	ZS4-SF1 TERMINAL BLOCK FOR FUSES	FU237, FU287, FU305, FU310, FU315, FU320, FU325, FU329, FU333, FU337, FU355, FU359, FU363, FU367, FU371, FU376, FU381, FU385
12	16	Q235003	LITTELFUSE	3.0 AMP FAST-ACTING CARTRIDGE FUSES, 5x20mm	FU305, FU310, FU315, FU320, FU325, FU329, FU333, FU337, FU355, FU359, FU363, FU367, FU371, FU376, FU381, FU385
13	1	MPET4-10R	ABB	NON-ILLUMINATED EMERGENCY STOP PUSH BUTTON, - TWIST RELEASE	PB118
14	1	MCB-01	ABB	CONTACT BLOCK (1 NC)	PB118
15	1	ML1-100W	ABB	PILOT LIGHT, MODULAR RANGE, WHITE LENS	LT126
16	1	MLBL-04W	ABB	120VAC WHITE LED PILOT LIGHT LAMP BLOCK	LT126
17	2	Q235.500	LITTELFUSE	0.50 AMP FAST-ACTING CARTRIDGE FUSES, 5x20mm	FU237, FU287
18	1	15NK508418R0000	ABB	ZS10-SF TERMINAL BLOCK FOR 6.3x32 FUSES	FU114
19	1	Q325008	LITTELFUSE	8.0 AMP SLO-BLO FUSE	FU114
20	1	1SVR427032R0000	ABB	CP-E 24VDC/2.5A POWER SUPPLY	PW153
21	1	TDS15015R150	ERICO	CRITEC TDS SURGE DIVERTER, Uc 170V, In 25kA, I <sub>max</sub> 50kA	SUP107
22	7	55.32.8.120.0040	FINDER	IND. PLUG-IN RELAY, DPDT 10A, 120VAC COIL, AGNI CONTACT, LOCKABLE TEST BUTTON & MECH. INDICATOR	CR304, CR309, CR314, CR319, CR324, CR328, CR358, CR362, CR366, CR370, CR375
23	7	94.04	FINDER	RELAY SOCKET, DIN-RAIL/PANEL MOUNT, SCREW, 14 PINS, 10A, 250V	CR304, CR309, CR314, CR319, CR324, CR328, CR358, CR362, CR366, CR370, CR375
24	1	A36P30	HOFFMAN	SUB-PANEL, 31.00x27.00	
25	1	A363012LP	HOFFMAN	CONTINUOUS HINGE W/CLAMPS, TYPE 12 ENCLOSURE	
26	1	KBMG-212D	KB ELECTRONICS	ULTRACOMPACT REGENERATIVE DRIVE	VFD111
27	1	BMX XBP 0800	MODICON	M340 RACK, 8 SLOT	
28	2	BMX DRA 0805	MODICON	M340 DISCRETE RELAY OUTPUT MODULE	PLC303, PLC353
29	5	BMX FTB 2010	MODICON	M340 MODULE 20-WAY TERMINAL BLOCK, SCREW CLAMP	PLC204, PLC254, PLC303, PLC353, PLC604
30	2	BMX DAI 1604	MODICON	M340 DISCRETE INPUT MODULE	PLC204, PLC254
31	1	BMX AMO 0802	MODICON	M340 ANALOG OUTPUT MODULE, 8-CH	PLC604
32	2	BMX AMI 0810	MODICON	M340 ANALOG INPUT MODULE, 8-CH	PLC404, PLC504
33	2	BMX FTB 2820	MODICON	M340 MODULE 28-WAY TERMINAL BLOCK, SPRING CLAMP	PLC404, PLC504
34	1	BMX PRA 0100	MODICON	X80 REMOTE I/O ADAPTER	DV158
35	1	BMX CPS 2010	MODICON	M340 POWER SUPPLY MODULE - 17W	DV158A

**STANTEC**  
**THIS PAGE ONLY**  
**NO EXCEPTION TAKEN**

**INTEGRATED CONTROLS**  
 15707 S. Mohrville St  
 Olathe, KS 66062  
 Phone: (913) 782-9600  
 Fax: (913) 764-7829

THIS DRAWING CONTAINS MATERIAL AND/OR INFORMATION WHICH IS THE PROPERTY OF INTEGRATED CONTROLS, INC. AND SUPPLIED ONLY ON CONFIDENTIAL BASIS. NO TRANSMITTAL OR DISCLOSURE SHALL BE MADE TO ANY PERSON, FIRM, OR CORPORATION WITHOUT PRIOR WRITTEN APPROVAL OF INTEGRATED CONTROLS, INC.

REV	DATE	DESCRIPTION	BY	APP'D
1	7-19-18	SUBMITTAL 1 COMMENTS	TH	DC

**TMWA MT. ROSE, NV**  
**TRIDET HS PACKAGE SYSTEM**  
**SLAVE CONTROL PANEL 2**  
**BILL OF MATERIAL**

DRAWN BY: TH  
 CHECKED BY: GR  
 SCALE: NONE  
 DATE: 3-29-18  
 PROJECT# 03694-01-00  
 SHEET #  
**3 OF 9**

c:\pwworking\ESS2013\Shared Folders\Volatiles\CAD Design Documents\PROTO PROJECTS\BASIC PROJECT START\200 Panel Equipment.dwg

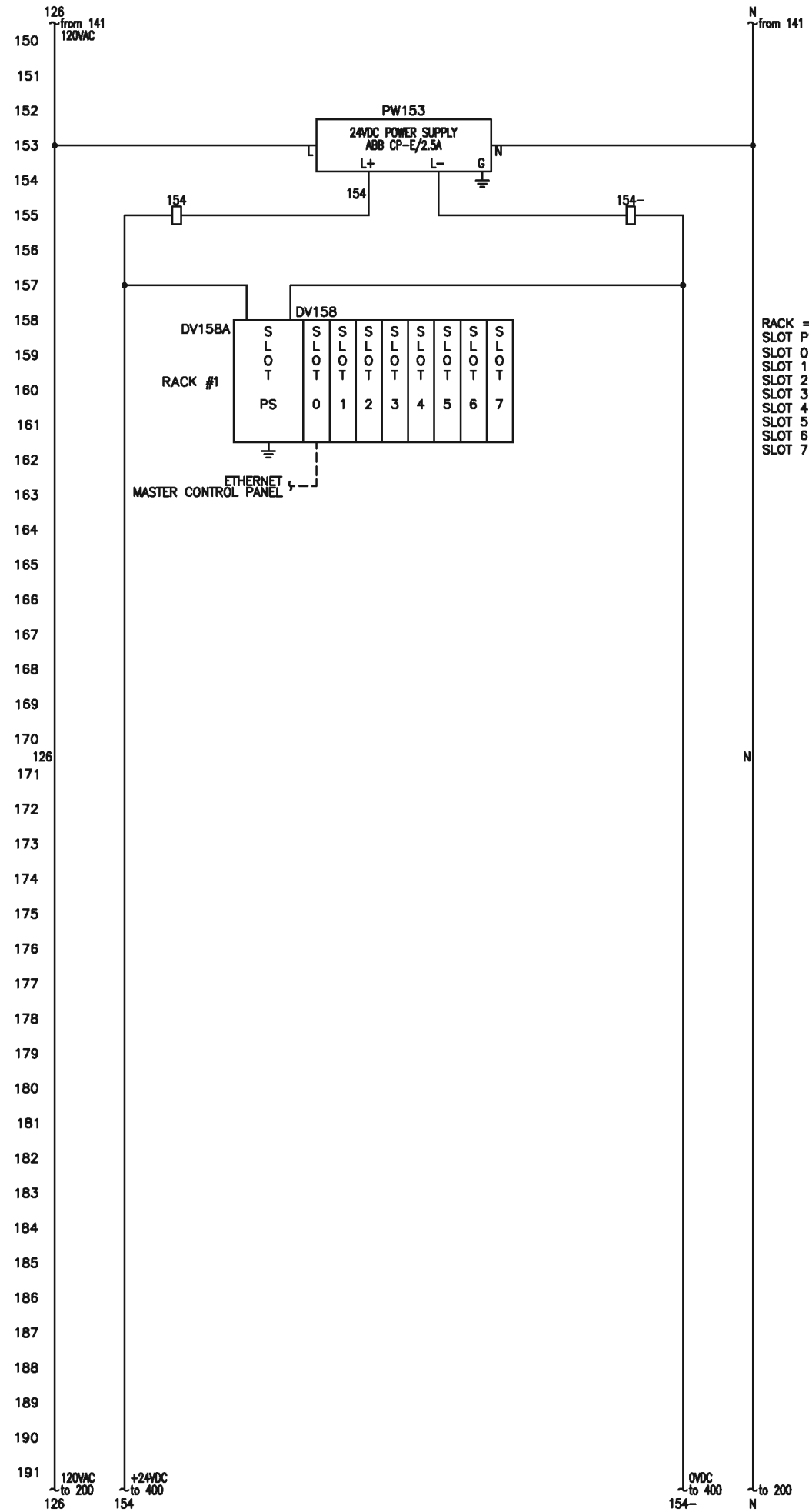
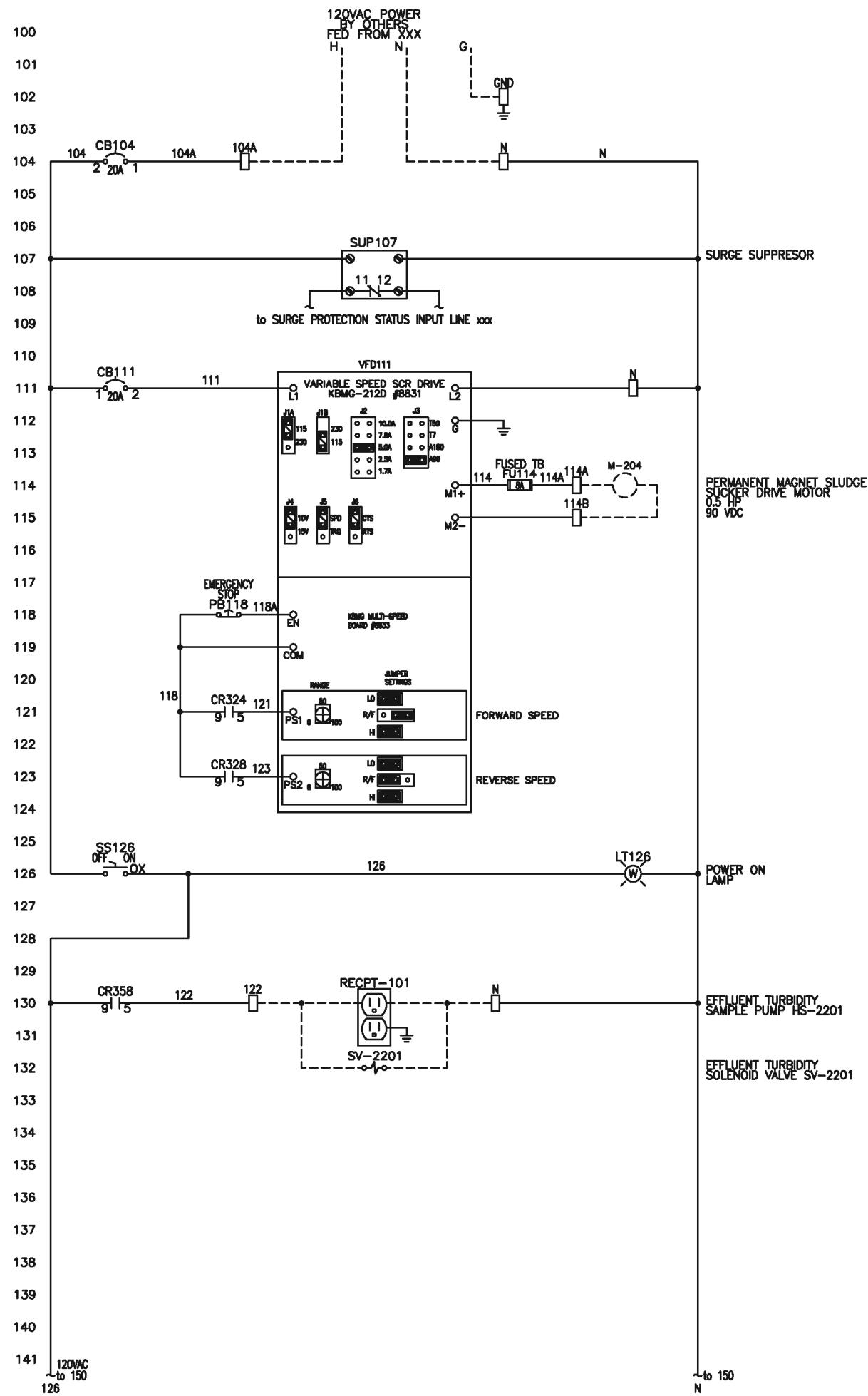

RACK = BMXXBP0800  
 SLOT PS = BMXCPS2010 POWER SUPPLY  
 SLOT 0 = BMXPRA0100 REMOTE I/O ADAPT.  
 SLOT 1 = BMXAMIO810 ANALOG IN  
 SLOT 2 = BMXAMIO810 ANALOG IN  
 SLOT 3 = BMXAMO0802 ANALOG OUT  
 SLOT 4 = BMXDAI1604 DISCRETE IN  
 SLOT 5 = BMXDAI1604 DISCRETE IN  
 SLOT 6 = BMXDRA0805 RELAY OUT  
 SLOT 7 = BMXDRA0805 RELAY OUT

THIS PAGE ONLY  
NO EXCEPTIONS

**STANEC**  
**INTEGRATED CONTROLS, INC.**  
 15707 S. Mahaffey St.  
 Olathe, KS 66062  
 Phone: (913) 782-9600  
 Fax: (913) 764-7829

THIS DRAWING CONTAINS MATERIAL AND/OR INFORMATION WHICH IS THE PROPERTY OF INTEGRATED CONTROLS, INC. AND SUPPLIED ONLY ON CONFIDENTIAL BASIS. NO TRANSMITTAL OR DISCLOSURE SHALL BE MADE TO ANY PERSON, FIRM, OR CORPORATION WITHOUT PRIOR WRITTEN APPROVAL OF INTEGRATED CONTROLS, INC.

REV	DATE	DESCRIPTION	BY	APP'D
1	7-19-18	SUBMITTAL 1 COMMENTS	TH	

**TMWA MT. ROSE, NV  
 TRIDET HS PACKAGE SYSTEM  
 SLAVE CONTROL PANEL 2  
 SCHEMATICS**

DRAWN BY:	TH
CHECKED BY:	GR
SCALE:	NONE
DATE:	3-29-18
PROJECT#:	03694-01-00
SHEET #:	

\\ESS2013\Shared\_Folders\volatiles\CAD Design Documents\PROJECTS\BASIC PROJECT START\300 Name.dwg

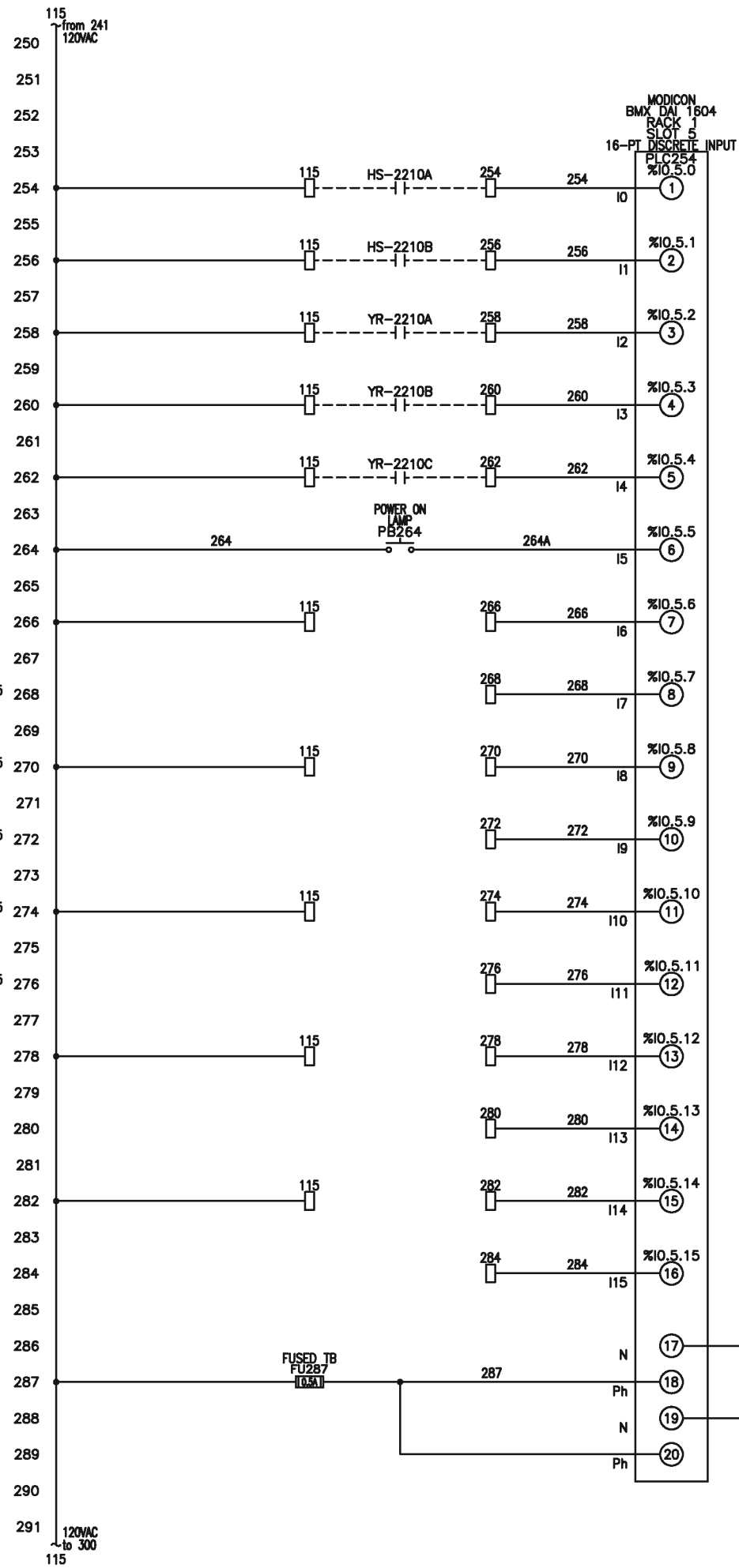
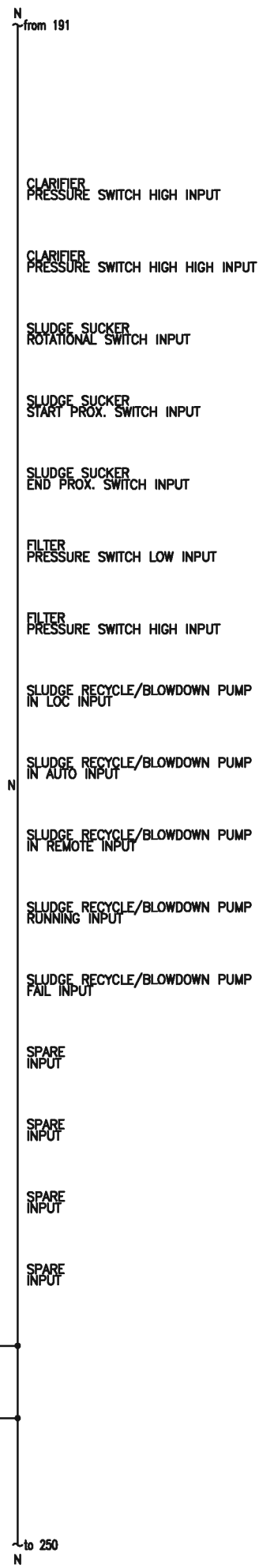
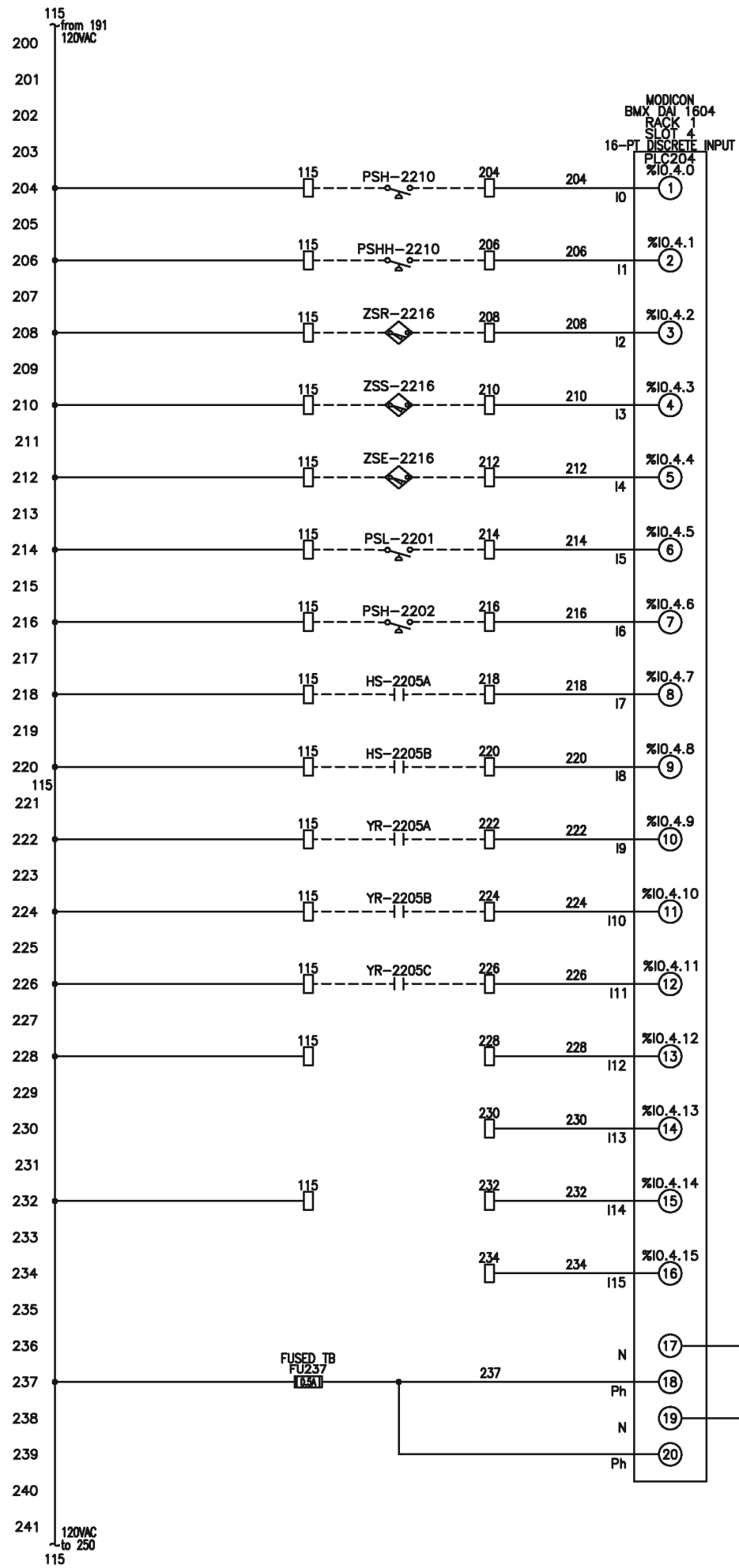

**STANTEC**  
**THIS PAGE ONLY**  
**NO EXCEPTION TAKEN**

INTEGRATED CONTROLS  
 15707 S. Mohrville St  
 Olathe, KS 66062  
 Phone: (913) 782-9600  
 Fax: (913) 784-7829

THIS DRAWING CONTAINS MATERIAL AND/OR INFORMATION WHICH IS THE PROPERTY OF INTEGRATED CONTROLS, INC. AND SUPPLIED ONLY ON CONFIDENTIAL BASIS. NO TRANSMITTAL OR DISCLOSURE SHALL BE MADE TO ANY PERSON, FIRM, OR CORPORATION WITHOUT PRIOR WRITTEN APPROVAL OF INTEGRATED CONTROLS, INC.

REV	DATE	DESCRIPTION	BY	APP'D
1	7-19-18	SUBMITTAL 1 COMMENTS	TH	DC

**TMWA MT. ROSE, NV**  
**TRIDET HS PACKAGE SYSTEM**  
**SLAVE CONTROL PANEL 2**  
**SCHEMATICS**

DRAWN BY: TH  
 CHECKED BY: GR  
 SCALE: NONE  
 DATE: 3-29-28  
 PROJECT#: 03694-01-00  
 SHEET #  
**5 OF 9**

\\ESS2013\Shared\_Folders\volatiles\CAD Design Documents\PROJECTS\BASIC PROJECT START\400 Name.dwg

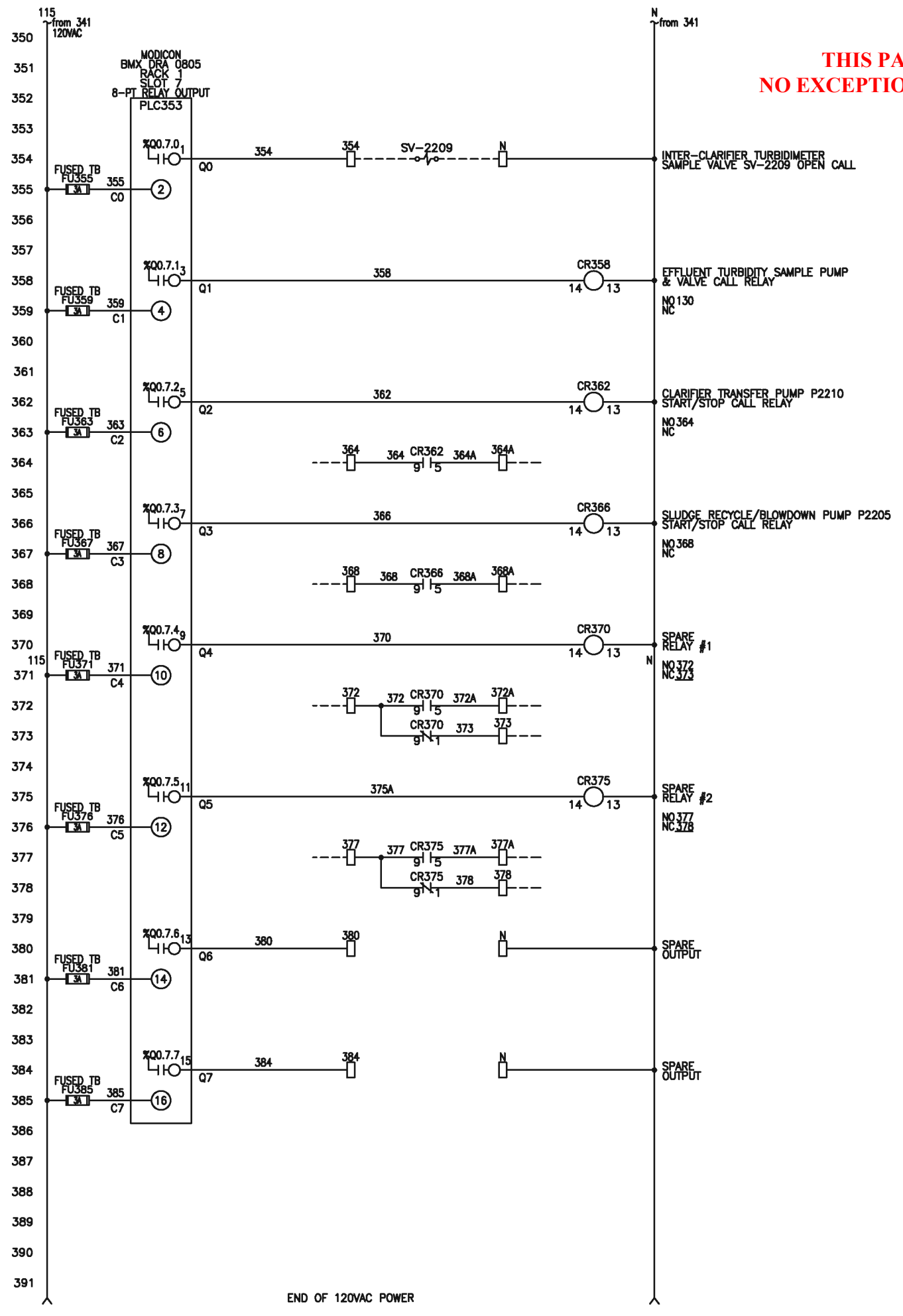
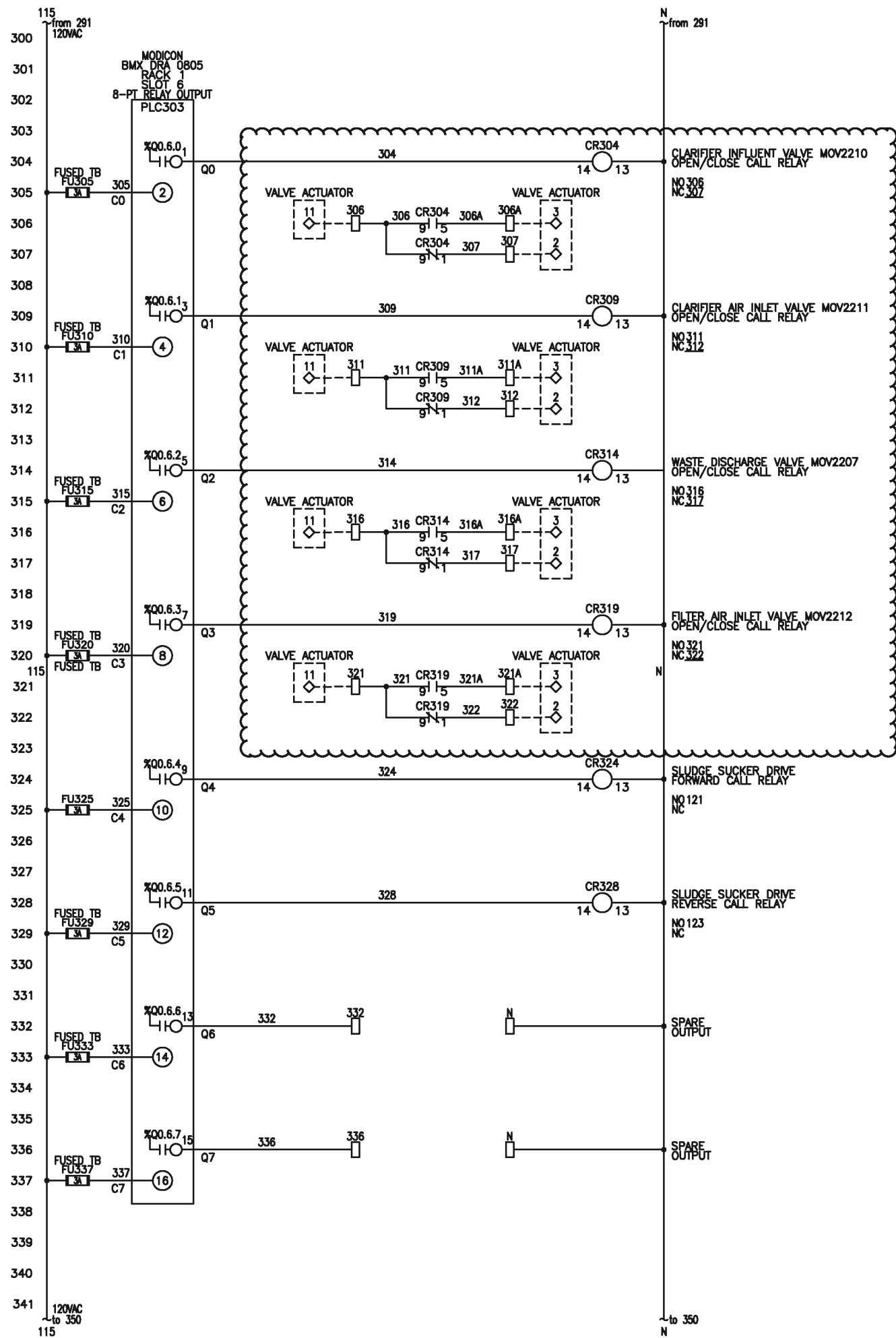

**STANTEC**  
**THIS PAGE ONLY**  
**NO EXCEPTION TAKEN**

INTEGRATED CONTROLS  
 15707 S. Manchester St  
 Olathe, KS 66062  
 Phone: (913) 782-9600  
 Fax: (913) 784-7829

THIS DRAWING CONTAINS MATERIAL AND/OR INFORMATION WHICH IS THE PROPERTY OF INTEGRATED CONTROLS, INC. AND SUPPLIED ONLY ON CONFIDENTIAL BASIS. NO TRANSMITTAL OR DISCLOSURE SHALL BE MADE TO ANY PERSON, FIRM, OR CORPORATION WITHOUT PRIOR WRITTEN APPROVAL OF INTEGRATED CONTROLS, INC.

REV	DATE	DESCRIPTION	BY	APP'D
1	7-19-18	SUBMITTAL 1 COMMENTS	TH	DC

**TMWA MT. ROSE, NV**  
**TRIDET HS PACKAGE SYSTEM**  
**SLAVE CONTROL PANEL 2**  
**SCHEMATICS**

DRAWN BY:	TH
CHECKED BY:	GR
SCALE:	NONE
DATE:	3-29-28
PROJECT#:	03694-01-00
SHEET #:	6 OF 9

c:\pwworking\SSS2013\Shared Folders\volatiles\CAD Design Documents\PROJECTS\BASIC PROJECT START\500 Name.dwg

400 154+ from 191 +24VDC  
 401  
 402  
 403  
 404  
 405  
 406  
 407  
 408  
 409  
 410  
 411  
 412  
 413  
 414  
 415  
 416  
 417  
 418  
 419  
 420 154+  
 421  
 422  
 423  
 424  
 425  
 426  
 427  
 428  
 429  
 430  
 431  
 432  
 433  
 434  
 435  
 436  
 437  
 438  
 439  
 440  
 441 +24VDC to 450 154+

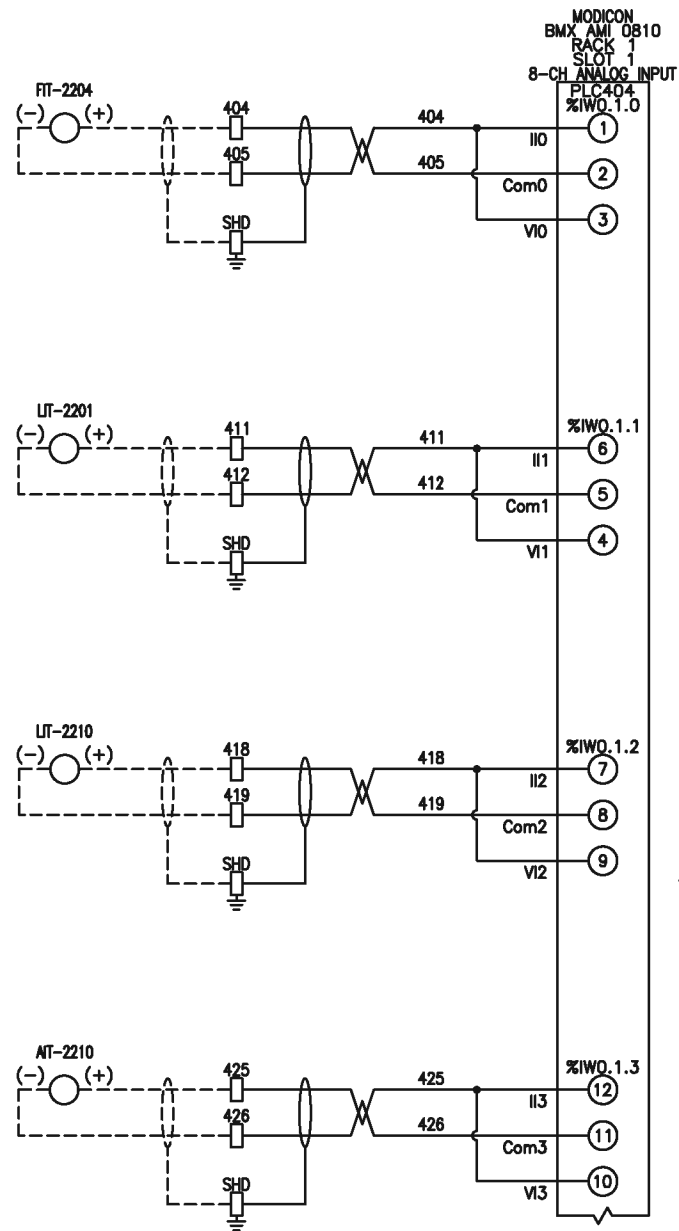

154- from 191 OVDC  
 INFLUENT FLOW INPUT  
 COLLECTOR LEVEL INPUT  
 FILTER LEVEL INPUT  
 154-  
 INTER-CLARIFIER TURBIDIMETER INPUT  
 OVDC to 450 154-

450 154+ from 441 +24VDC  
 451  
 452  
 453  
 454  
 455  
 456  
 457  
 458  
 459  
 460  
 461  
 462  
 463  
 464  
 465  
 466  
 467  
 468  
 469  
 470 154+  
 471  
 472  
 473  
 474  
 475  
 476  
 477  
 478  
 479  
 480  
 481  
 482  
 483  
 484  
 485  
 486  
 487  
 488  
 489  
 490  
 491 +24VDC to 500 154+

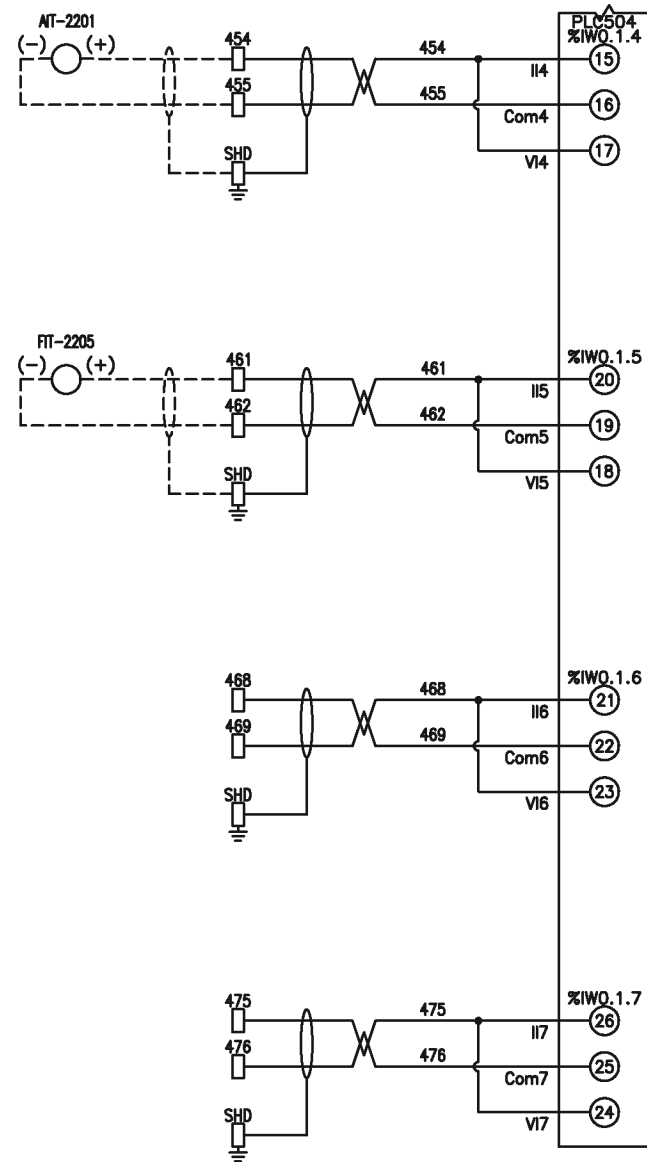

154- from 441 OVDC  
 EFFLUENT TURBIDIMETER INPUT  
 SLUDGE RECYCLE FLOW INPUT  
 SPARE INPUT  
 154-  
 SPARE INPUT  
 OVDC to 500 154-

**STANTEC**  
**THIS PAGE ONLY**  
**NO EXCEPTION TAKEN**

**INTEGRATED CONTROLS**  
 15707 S. Monarche St  
 Olathe, KS 66062  
 Phone: (913) 782-9600  
 Fax: (913) 784-7829

THIS DRAWING CONTAINS MATERIAL AND/OR INFORMATION WHICH IS THE PROPERTY OF INTEGRATED CONTROLS, INC. AND SUPPLIED ONLY ON CONFIDENTIAL BASIS. NO TRANSMITTAL OR DISCLOSURE SHALL BE MADE TO ANY PERSON, FIRM, OR CORPORATION WITHOUT PRIOR WRITTEN APPROVAL OF INTEGRATED CONTROLS, INC.

REV	DATE	DESCRIPTION	BY	APP'D
1	7-19-18	SUBMITTAL 1 COMMENTS	TH	DC

**TMWA MT. ROSE, NV**  
**TRIDET HS PACKAGE SYSTEM**  
**SLAVE CONTROL PANEL 2**  
**SCHEMATICS**

DRAWN BY:	TH
CHECKED BY:	GR
SCALE:	NONE
DATE:	3-29-28
PROJECT#:	03694-01-00
SHEET #	7 OF 9



c:\msd\13\Shared\Folders\volatiles\CAD Design Documents\PROJECTS\BASIC PROJECT START\600 Name.dwg

600 154+  
601 from 591  
602 +24VDC  
603  
604  
605  
606  
607  
608  
609  
610  
611  
612  
613  
614  
615  
616  
617  
618  
619  
620  
621 154+  
622  
623  
624  
625  
626  
627  
628  
629  
630  
631  
632  
633  
634  
635  
636  
637  
638  
639  
640  
641 +24VDC  
154+  
to 650

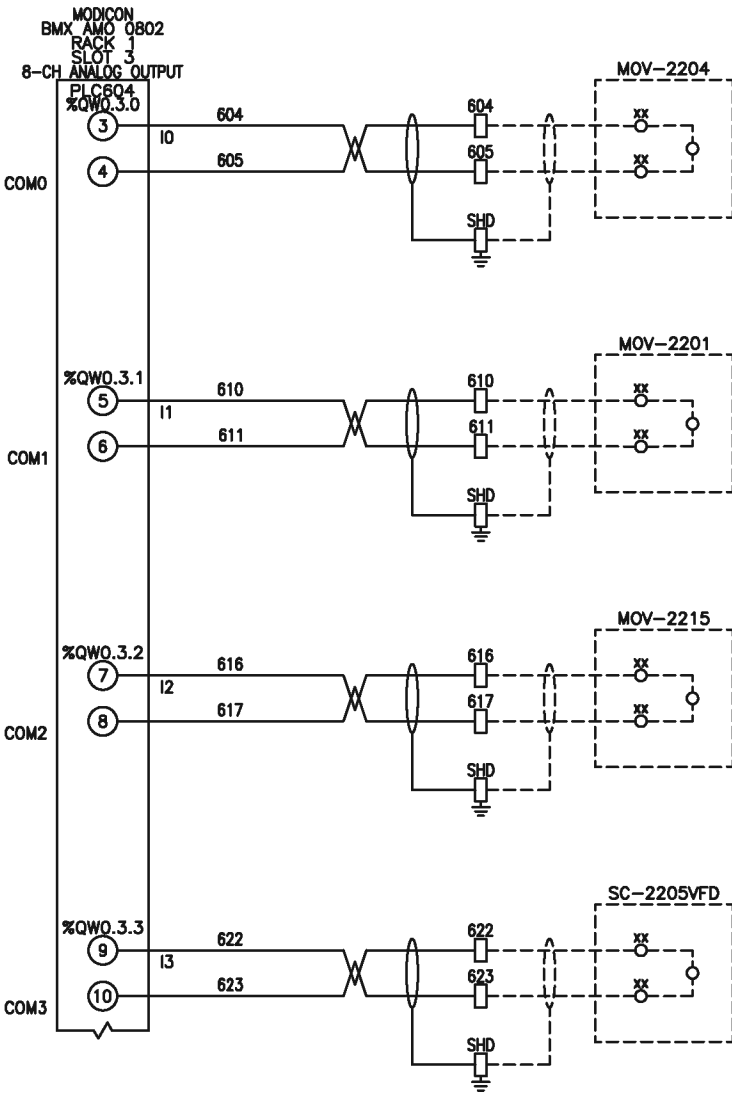

154-  
from 591  
OVDC  
154-  
OVDC  
to 650  
154-

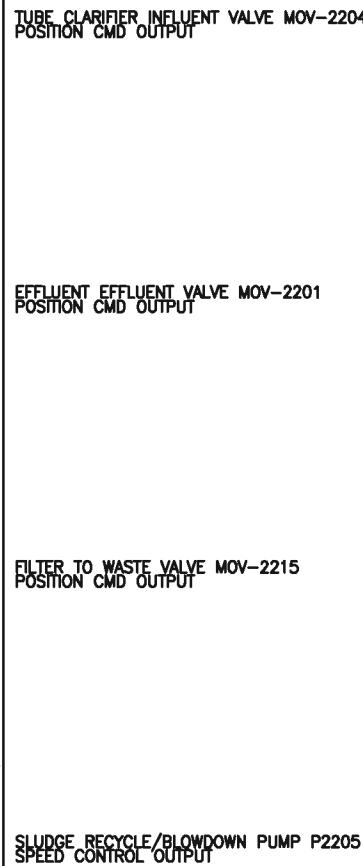

154+  
from 641  
+24VDC  
650  
651  
652  
653  
654  
655  
656  
657  
658  
659  
660  
661  
662  
663  
664  
665  
666  
667  
668  
669  
670  
671 154+  
672  
673  
674  
675  
676  
677  
678  
679  
680  
681  
682  
683  
684  
685  
686  
687  
688  
689  
690  
691

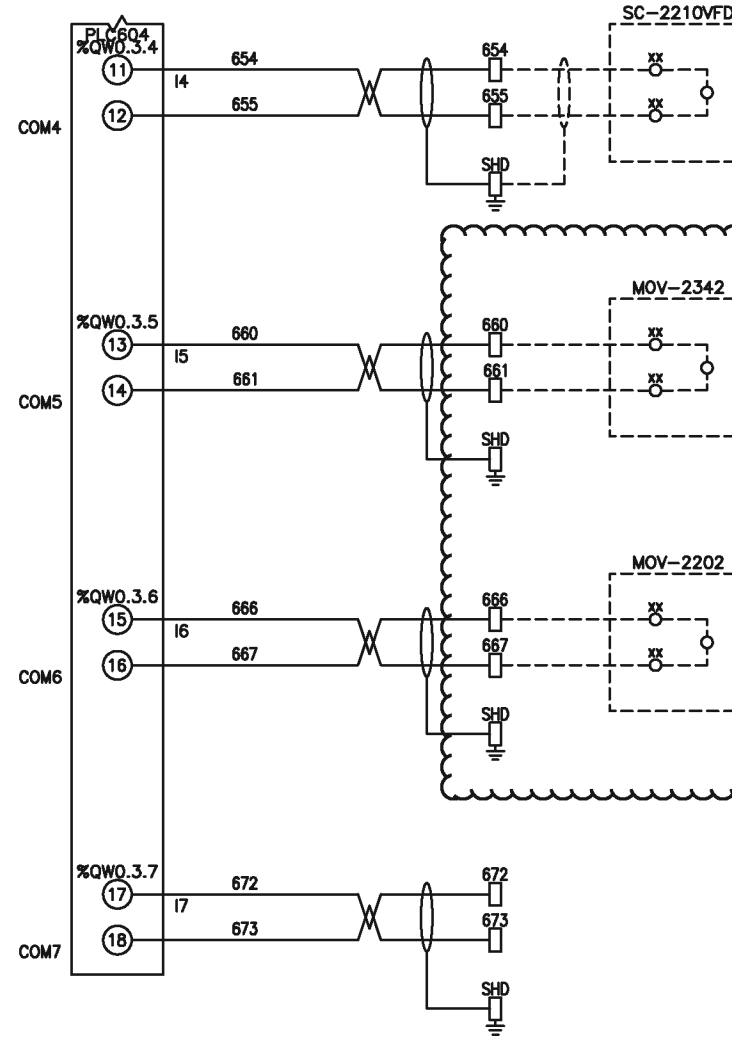

154-  
from 641  
OVDC  
154-  
OVDC  
to 650  
154-

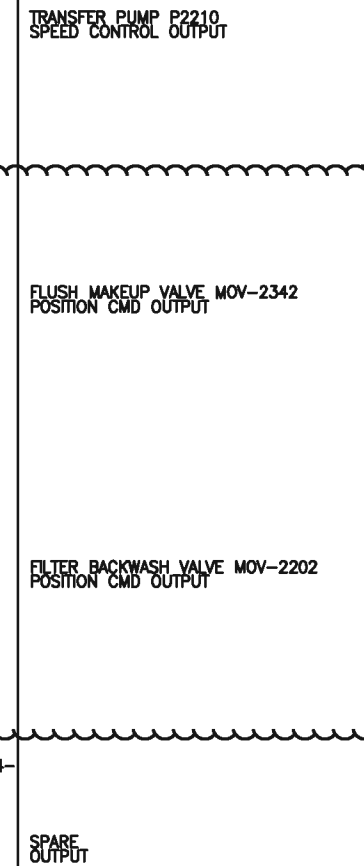

END OF 24VDC POWER  
END OF ELECTRICAL DRAWINGS

THIS PAGE ONLY  
NO EXCEPTION TAKEN

**STANTEC**  
INTEGRATED CONTROLS  
15707 S. Manierre St  
Olathe, KS 66062  
Phone: (913) 782-9600  
Fax: (913) 764-7829

THIS DRAWING CONTAINS MATERIAL AND/OR INFORMATION WHICH IS THE PROPERTY OF INTEGRATED CONTROLS, INC. AND SUPPLIED ONLY ON CONFIDENTIAL BASIS. NO TRANSMITTAL OR DISCLOSURE SHALL BE MADE TO ANY PERSON, FIRM, OR CORPORATION WITHOUT PRIOR WRITTEN APPROVAL OF INTEGRATED CONTROLS, INC.

REV	DATE	DESCRIPTION	BY	APP'D
1	7-19-18	SUBMITTAL 1 COMMENTS	TH	DC

**TMWA MT. ROSE, NV  
TRIDET HS PACKAGE SYSTEM  
SLAVE CONTROL PANEL 2  
SCHEMATICS**

DRAWN BY:	TH
CHECKED BY:	GR
SCALE:	NONE
DATE:	3-29-28
PROJECT#:	03694-01-00
SHEET #:	

**STANTEC**  
**THIS PAGE ONLY**  
**NO EXCEPTION TAKEN**

SUBMITTAL  
Do Not Use  
For Installation

This Page was left blank intentionally.

**STANTEC**  
**THIS PAGE ONLY**  
**NO EXCEPTION TAKEN**

SUBMITTAL  
Do Not Use  
For Installation

# SECTION 5

**Bill of Materials**

**STANTEC**  
**THIS PAGE ONLY**  
**NO EXCEPTION TAKEN**

SUBMITTAL  
Do Not Use  
For Installation

This Page was left blank intentionally.

**BILL OF MATERIAL - TMWA Mt. Rose, NV (1 of 3)**

Master Panel				QTY	CATALOG	MFG	DESC
	1	1489-M1C200	ABB	20AMP, 1-POLE, M1C, CIRCUIT BREAKER, BULLETIN 1489 SERIES			
	1	9300-RADES	ABB	REMOTE ACCESS DIAL-IN MODEM			
	6	1SNK900001R0000	ABB	BAM3 END STOP			
	140	1SNK506010R0000	ABB	Z56 GREY 6mm SCREW CLAMP TERMINAL BLOCK			
	3	1SNK505910R0000	ABB	E54 SCREW CLAMP TERMINAL BLOCK END COVER			
	20	1SNK506150R0000	ABB	Z56-PE 6mm SCREW CLAMP TERMINAL GROUNDING BLOCK			
	18	1SNK508410R0000	ABB	Z54-SF1 TERMINAL BLOCK FOR FUSES			
	1	1SNK508960R0000	ABB	E54-SF TERMINAL BLOCK END COVER			
	1	IMP1-10B	ABB	NON-ILLUMINATED PUSH BUTTON, FLUSH, MOMENTARY, 22mm, BLACK			
	1	M2SS1-10B	ABB	2 POSITION SELECTOR SWITCH (CENTER TO RIGHT), MAINTAINED, 22mm, BLACK			
	1	ML1-100W	ABB	PILOT LIGHT, MODULAR RANGE, WHITE LENS			
	1	MLBL-04W	ABB	120VAC WHITE LED PILOT LIGHT LAMP BLOCK			
	3	MCBH-00	ABB	MODULAR HOLDER			
	2	MCB-10	ABB	CONTACT BLOCK, 1 N.O.			
	1	1SYR42703R0000	ABB	120VAC 2-5 AMP POWER SUPPLY			
	1	HMIGT06310	SCHNEIDER ELECTRIC	MAGELUS GTO 12.1" TFT LCD TOUCHSCREEN HMI			
	1	EDS1505150	CRUCIBLE SUBSIDIARY	CRUCIBLE SUBSIDIARY, 170V, 10A, 50KA, 10A x 50KA			
	11	55-32.8.120.0040	FINDER	IND. PLUG-IN RELAY, DPDT 10A, 120VAC COIL, AGNI CONTACT, LOCKABLE TEST BUTTON & MECH. INDICATOR			
	11	94.04	FINDER	RELAY SOCKET, DIN-RAIL/PANEL MOUNT, SCREW, 14 PINS, 10A, 250V			
	2	94.06	FINDER	6-WAY JUMPER LINK			
	1	MB-V09-201-S(M)	FLOYD BELL	AUDIOLARM II ALARM HORN, VOLUME CONTROL, 30-120VAC			
	1	61663	FLOYD BELL	ALARM HORN GASKET			
	1	P-Q6R2-M3RF3	GRACEPORT	INSIDE/OUTSIDE OUTLET, GFCI, NEMA 12/4, ETHERNET, PHONE, 3A BREAKER			
	1	A36P30	HOFFMAN	SUB-PANEL, 31.00x27.00			
	1	A363012LP	HOFFMAN	CONTINUOUS HINGE W/CLAMPS, TYPE 12 ENCLOSURE			
	2	0235-500	LITTELFUSE	0.50 AMP FAST-ACTING CARTRIDGE FUSES, 5x20mm			
	16	0235003	LITTELFUSE	3.0 AMP FAST-ACTING CARTRIDGE FUSES, 5x20mm			
	2	BMX DRA 0805	SCHNEIDER ELECTRIC	MODICON MODICON M340 DISCRETE RELAY OUTPUT MODULE			
	2	BMX DAI 1604	SCHNEIDER ELECTRIC	MODICON M340 DISCRETE INPUT MODULE			
	1	BMX AMO 0802	SCHNEIDER ELECTRIC	MODICON M340 ANALOG OUTPUT MODULE, 8-CH			
	1	BMX AMI 0810	SCHNEIDER ELECTRIC	MODICON M340 ANALOG INPUT MODULE, 8-CH			
	5	BMX FTB 2010	SCHNEIDER ELECTRIC	MODICON M340 MODULE 20-WAY TERMINAL BLOCK, SCREW CLAMP			
	1	BMX FTB 2820	SCHNEIDER ELECTRIC	MODICON M340 MODULE 28-WAY TERMINAL BLOCK, SPRING CLAMP			
	1	BMX P34 2020	SCHNEIDER ELECTRIC	MODICON M340 PROCESSOR MODULE			
	1	BMX XBP 0800	SCHNEIDER ELECTRIC	MODICON M340 8 SLOT CHASSIS			
	1	BMX CPS 2010	SCHNEIDER ELECTRIC	MODICON M340 POWER SUPPLY MODULE - 17W			
	1	BMX XEM 010	SCHNEIDER ELECTRIC	PROTECTIVE COVER FOR UNUSED SLOTS ON MODICON M340 RACK			
	1	EDS-516A	MOXA	16-PORT MANAGED ETHERNET SWITCH			

**STANTEC  
THIS PAGE ONLY  
NO EXCEPTION TAKEN**

SUBMITTAL  
Do Not Use  
For Installation

**BILL OF MATERIAL - TMWA Mt. Rose, NV (2 of 3)**

Slave Panel 1			
QTY	CATALOG	MFG	DESC
2	1489-M1C200	ABB	20AMP, 1-POLE, M1C, CIRCUIT BREAKER, BULLETIN 1489 SERIES
6	1SNK900001R0000	ABB	BAM3 END STOP
160	1SNK506010R0000	ABB	Z56 GREY 6mm SCREW CLAMP TERMINAL BLOCK
3	1SNK505910R0000	ABB	ES4 SCREW CLAMP TERMINAL BLOCK END COVER
28	1SNK506150R0000	ABB	Z56-PE 6mm SCREW CLAMP TERMINAL GROUNDING BLOCK
18	1SNK508410R0000	ABB	Z54-SF1 TERMINAL BLOCK FOR FUSES
1	1SNK508960R0000	ABB	ES4-SF TERMINAL BLOCK END COVER
1	1SNK508418R0000	ABB	Z510-SF TERMINAL BLOCK FOR 6.3x32 FUSES
1	1SVR427032R0000	ABB	CP-E 24VDC/2.5A POWER SUPPLY
1	MP1-10B	ABB	NON-ILLUMINATED PUSH BUTTON, FLUSH, MOMENTARY, 22mm, BLACK
1	M2S51-10B	ABB	2 POSITION SELECTOR SWITCH (CENTER TO RIGHT), MAINTAINED, 22mm, BLACK
1	MPET4-10R	ABB	NON-ILLUMINATED EMERGENCY STOP PUSH BUTTON, - TWIST RELEASE
1	ML1-100W	ABB	PILOT LIGHT, MODULAR RANGE, WHITE LENS
1	MLBL-04W	ABB	120VAC WHITE LED PILOT LIGHT LAMP BLOCK
4	MGBH-00	ABB	MODULAR HOLDER
2	MGB-10	ABB	CONTACT BLOCK, 1 N.O.
1	MGB-01	ABB	CONTACT BLOCK, 1 N.C.
1	TDS1501SR150	ERICO	CRITEC TDS SURGE DIVERTER, Uc 170V, In 25ka, Imax 50ka
11	55.32.8.120.0040	FINDER	IND. PLUG-IN RELAY, DPDT 10A, 120VAC COIL, AGNI CONTACT, LOCKABLE TEST BUTTON & MECH. INDICATOR
11	94.04	FINDER	RELAY SOCKET, DIN-RAIL/PANEL MOUNT, SCREW, 14 PINS, 10A, 250V
1	94.06	FINDER	6-WAY JUMPER LINK
1	A36P30	HOFFMAN	SUB-PANEL, 31.00x27.00
1	A363012LP	HOFFMAN	CONTINUOUS HINGE W/CLAMPS, TYPE 12 ENCLOSURE
1	KBMG-212D	KB ELECTRONICS	ULTRACOMPACT REGENERATIVE DRIVE
16	0235003	LITTELFUSE	3.0 AMP FAST-ACTING CARTRIDGE FUSES, 5x20mm
2	0235.500	LITTELFUSE	0.50 AMP FAST-ACTING CARTRIDGE FUSES, 5x20mm
1	0325008	LITTELFUSE	8.0 AMP SLO-BLO FUSE
2	BMX DRA 0805	SCHNEIDER ELECTRIC	MODICON M340 DISCRETE RELAY OUTPUT MODULE
2	BMX DAI 1604	SCHNEIDER ELECTRIC	MODICON M340 DISCRETE INPUT MODULE
1	BMX AMO 0802	SCHNEIDER ELECTRIC	MODICON M340 ANALOG OUTPUT MODULE, 8-CH
2	BMX AMI 0810	SCHNEIDER ELECTRIC	MODICON M340 ANALOG INPUT MODULE, 8-CH
5	BMX FTB 2010	SCHNEIDER ELECTRIC	MODICON M340 MODULE 20-WAY TERMINAL BLOCK, SCREW CLAMP
2	BMX FTB 2820	SCHNEIDER ELECTRIC	MODICON M340 MODULE 28-WAY TERMINAL BLOCK, SPRING CLAMP
1	BMX XBP 0800	SCHNEIDER ELECTRIC	MODICON M340 RACK, 8 SLOT
1	BMX PRA 0100	SCHNEIDER ELECTRIC	MODICON X80 REMOTE I/O ADAPTER
1	BMX CPS 2010	SCHNEIDER ELECTRIC	MODICON M340 POWER SUPPLY MODULE - 17W

**STANTEC  
THIS PAGE ONLY  
NO EXCEPTION TAKEN**

**BILL OF MATERIAL - TMWA Mt. Rose, NV (3 of 3)**

Slave Panel 2			
QTY	CATALOG	MFG	DESC
2	1489-M1C200	ABB	20AMP, 1-POLE, M1C, CIRCUIT BREAKER, BULLETIN 1489 SERIES
6	1SNK900001R0000	ABB	BAM3 END STOP
160	1SNK506010R0000	ABB	Z56 GREY 6mm SCREW CLAMP TERMINAL BLOCK
3	1SNK505910R0000	ABB	E54 SCREW CLAMP TERMINAL BLOCK END COVER
28	1SNK506150R0000	ABB	Z56-PE 6mm SCREW CLAMP TERMINAL GROUNDING BLOCK
1	1SNK508960R0000	ABB	E54-SF TERMINAL BLOCK END COVER
18	1SNK508410R0000	ABB	Z54-SF1 TERMINAL BLOCK FOR FUSES
1	1SNK508418R0000	ABB	Z510-SF TERMINAL BLOCK FOR 6.3x32 FUSES
1	IMP1-10B	ABB	NON-ILLUMINATED PUSH BUTTON, FLUSH, MOMENTARY, 22mm, BLACK
1	M2S51-10B	ABB	2 POSITION SELECTOR SWITCH (CENTER TO RIGHT), MAINTAINED, 22mm, BLACK
1	MPET4-10R	ABB	NON-ILLUMINATED EMERGENCY STOP PUSH BUTTON, - TWIST RELEASE
1	ML1-100W	ABB	PILOT LIGHT, MODULAR RANGE, WHITE LENS
1	MLBL-04W	ABB	120VAC WHITE LED PILOT LIGHT LAMP BLOCK
4	MCBH-00	ABB	MODULAR HOLDER
2	MCB-10	ABB	CONTACT BLOCK, 1 N.O.
1	MCB-01	ABB	CONTACT BLOCK, 1 N.C.
1	1SVR427032R0000	ABB	CP-E 24VDC/2.5A POWER SUPPLY
1	TDS1501SR150	ERICO	CRITEC TDS SURGE DIVERTER, Uc 170V, In 25ka, Imax 50ka
11	55.32.8.120.0040	FINDER	IND. PLUG-IN RELAY, DPDT 10A, 120VAC COIL, AGNI CONTACT, LOCKABLE TEST BUTTON & MECH. INDICATOR
11	94.04	FINDER	RELAY SOCKET, DIN-RAIL/PANEL MOUNT, SCREW, 14 PINS, 10A, 250V
1	94.06	FINDER	6-WAY JUMPER LINK
1	A36P30	HOFFMAN	SUB-PANEL, 31.00x27.00
1	A363012LP	HOFFMAN	CONTINUOUS HINGE W/CLAMPS, TYPE 12 ENCLOSURE
1	KBMG-212D	KB ELECTRONICS	ULTRACOMPACT REGENERATIVE DRIVE
16	0235003	LITTELFUSE	3.0 AMP FAST-ACTING CARTRIDGE FUSES, 5x20mm
2	0235.500	LITTELFUSE	0.50 AMP FAST-ACTING CARTRIDGE FUSES, 5x20mm
1	0325008	LITTELFUSE	8.0 AMP SLO-BLO FUSE
2	BMX DRA 0805	SCHNEIDER ELECTRIC	MODICON M340 DISCRETE RELAY OUTPUT MODULE
2	BMX DAI 1604	SCHNEIDER ELECTRIC	MODICON M340 DISCRETE INPUT MODULE
1	BMX AMO 0802	SCHNEIDER ELECTRIC	MODICON M340 ANALOG OUTPUT MODULE, 8-CH
2	BMX AMI 0810	SCHNEIDER ELECTRIC	MODICON M340 ANALOG INPUT MODULE, 8-CH
5	BMX FTB 2010	SCHNEIDER ELECTRIC	MODICON M340 MODULE 20-WAY TERMINAL BLOCK, SCREW CLAMP
2	BMX FTB 2820	SCHNEIDER ELECTRIC	MODICON M340 MODULE 28-WAY TERMINAL BLOCK, SPRING CLAMP
1	BMX XBP 0800	SCHNEIDER ELECTRIC	MODICON M340 RACK, 8 SLOT
1	BMX PRA 0100	SCHNEIDER ELECTRIC	MODICON X80 REMOTE I/O ADAPTER
1	BMX CPS 2010	SCHNEIDER ELECTRIC	MODICON M340 POWER SUPPLY MODULE - 17W

**STANTEC  
THIS PAGE ONLY  
NO EXCEPTION TAKEN**

**STANTEC**  
**THIS PAGE ONLY**  
**NO EXCEPTION TAKEN**

SUBMITTAL  
Do Not Use  
For Installation

This Page was left blank intentionally.

**STANTEC**  
**THIS PAGE ONLY**  
**NO EXCEPTION TAKEN**

SUBMITTAL  
Do Not Use  
For Installation

# SECTION 6

**Cut-Sheets**

**STANTEC**  
**THIS PAGE ONLY**  
**NO EXCEPTION TAKEN**

SUBMITTAL  
Do Not Use  
For Installation

This Page was left blank intentionally.

# 1489-M Circuit Breakers

STANTEC

THIS PAGE ONLY  
NO EXCEPTION TAKEN

SUBMITTAL  
Do Not Use  
For Installation



Bulletin 1489-M thermal magnetic Circuit Breakers are approved for branch circuit protection in the United States and Canada, and are certified as Miniature Circuit Breakers for IEC applications.

These branch protectors are compatible with many accessories to meet diverse application needs, including UL 508 Listed bus bars for convenience in panel assembly, auxiliary contacts, signal contacts and shunt trips for versatility, and lock out attachments for safety during maintenance.

## Features

- Current limiting
- Fast breaking time
- High rated voltage
- Superior shock and vibration resistance to help prevent nuisance tripping
- Dual terminals allow the connection of two wires, or both a wire and bus bar (self declared)
- Terminal design helps prevent wiring misses by directing wires into the terminal openings, even while tightening
- Reversible line and load connections
- Single and multi-pole toggle mount lock out attachments available for Lock Out Tag Out (LOTO)
- RoHS compliant and fully-recyclable device
- Suitable for extreme ambient conditions

### 1489-M Circuit Breakers

<b>Rated Voltage</b>	UL/CSA: Max. 480Y/277V AC IEC: Ue 230/400V AC
<b>Interrupting Capacity</b>	UL/CSA: 10 kA IEC: 15 kA
<b>Current Ratings</b>	0.5...63 A
<b>Poles</b>	1, 2, 3
<b>Trip Curves</b>	C, D
<b>Standards Compliance</b>	UL 489 CSA C22.2 No. 5.1 EN 60947-2 GB 14048.2
<b>Certifications</b>	UL Listed, File No. E197878 CSA Certified CE Marked VDE Certified CCC Certified RoHS Compliant



## Remote Access Modem Kits

### Remote Connection Solutions For Your Control Systems

#### Serial Modems

- Designed for use in industrial environments
- Compact design uses only 2 inches of DIN rail space
- Flexible power requirements
- Phone line connection speeds up to 56K
- Multiple cables and adaptors are provided for connection to a variety of control system components
- Remote configuration (allows reconfiguration of a remote modem to match changes in the control system)
- Password protection, password with callback and Caller ID (protects control systems from unauthorized access)
- Profile selection switches (allow preprogrammed profiles to be selected without connecting to a computer)

#### Ethernet Modems

- Designed for use in industrial environments
- Compact design uses only 2 inches of DIN rail space
- Flexible power requirements
- Phone line connection speeds up to 56K
- Data compression increases phone line throughput by 40%
- 17 diagnostics LEDs report system status and network activity
- VLAN capability reduces network traffic
- Network debugging with port mirroring and port diagnostics
- IGMP Snooping to minimize network traffic
- Dial-out capability to route packets to other networks
- Multiple levels of security:
- DHCP/BOOTP server (services up to 30 nodes on your network)



*Remote Access Modem Kits are specifically designed for remote connection to control systems and include everything you need to easily connect the first time, and every time.*

Remotely connecting to a control system using an off-the-shelf, computer store modem can often be a difficult task.

Remote Access Dial-in Ethernet Modems allow you to quickly connect to your remote Ethernet network from any standard phone line, improving your ability to respond to critical situations without actually being on site. Now you can eliminate those weekend trips to the plant, or costly travel to field locations.

From home, your office or another facility, you can easily:

- Perform diagnostics
- Make program changes
- Upload and download new programs
- Update firmware
- Collect data
- Monitor system status

# Specifications

**STANTEC**  
**THIS PAGE ONLY**  
**NO EXCEPTION TAKEN**

SUBMITTAL  
Do Not Use  
For Installation

	<b>9300-RADES</b> Remote Access Dial-in Ethernet Modem	<b>9300-RADKIT</b> Remote Access Dial-in Modem	<b>9300-RAPMKIT</b> Remote Access Paging Modem
Environmental:			
Operating Temperature:	0 TO 60° C (32 TO 152° F)		
Storage Temperature:	-20 TO 70° C (-4 TO 158° F)		
Weight:	1.5 LBS.		
Compliance:	FCC part 68, Part 15-class a, UL/CSA/IC Certified, CTR 21, CE, UL Class 1 Div 2 Hazardous	FCC part 68, Part 15-class b, UL/CSA/IC Certified, CTR 21, UL Class 1 Div. 2	FCC part 68, Part 15-class b, UL/CSA/IC Certified, CTR 21
Power Requirements:	8 to 48VDC (200 mA at 24V, 300mA max)	8 to 48VDC (100 MA at 24V, 200MA at 12V)	
Network Ports:	4 RJ-45 10/100 full/half duplex jacks		
DTE Rates (Asynchronous):	Host to DSP - Internal high speed serial interface	230.4K, 115K, 57.6K, 38.4K, 19.2K, 9600, 4800, 2400, 1200 and 300 bps	
Line Rates (V90):	56K thru 28K bps		
Line Rates (V.34):	28.8K thru 2400 bps		
Error Control/Data Compression:	V.42, V.42bis MNP Classes 3,4		
Phone Interface Connection:	RJ11C		
Phone Line Requirements:	Unconditioned PSTN dial-up		
Transmit Level:	Dial Line: -10dBm fixed		
Carrier Detect Threshold:	-10 to -43dBm		
Switch Characteristics:	VLAN, QoS, IGMP, Port Mirroring		
Routing Characteristics:	Automatic Dial-Out, DHCP, BOOTP, PAP, CHAP		
Protocols:	TCP/IP, PPP, RIP, NAT, Telnet, FTP, DHCP, BOOTP		
Switches:	4 Default Profile Selection Switches, Power Switch		
Facsimile Compatibility:	ITU Group 3 fax machines and fax modems, ITU V.17, V.29, V.27ter, V.21Channel 2, T.30, T.4, EIA-578 Class 1 compatibility for fax software		
Facsimile Operating Speeds:	Send/receive: 14,400 bps to 2400 bps		
Accessories:	Quick Start Guide, AC Adapter, 6 ft. Patch Cable, Phone line cable	Quick Start Guide, AC Adapter, Serial cable kit, Phone line cable	

## Ordering

To order a Remote Access Modem kit use the appropriate part number above.

## More Information

For more information about Remote Access Modems, contact your local Rockwell Automation sales office or authorized distributor, or visit:

<http://support.rockwellautomation.com/modem>

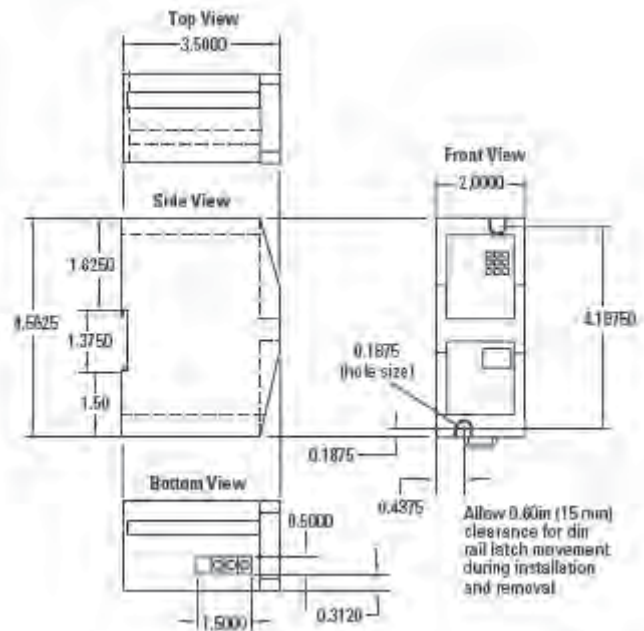

[www.rockwellautomation.com](http://www.rockwellautomation.com)

### Power, Control and Information Solutions Headquarters

Americas: Rockwell Automation, 1201 South Second Street, Milwaukee, WI 53204-2496 USA, Tel: (1) 414.382.2000, Fax: (1) 414.382.4444

Europe/Middle East/Africa: Rockwell Automation, Vorstlaan/Boulevard du Souverain 36, 1170 Brussels, Belgium, Tel: (32) 2 663 0600, Fax: (32) 2 663 0640

Asia Pacific: Rockwell Automation, Level 14, Core F, Cyberport 3, 100 Cyberport Road, Hong Kong, Tel: (852) 2887 4788, Fax: (852) 2508 1846

# ZS6 Screw Clamp Terminal Blocks

## Feed-through

**STANTEC**  
Technical Database  
**THIS PAGE ONLY**  
**NO EXCEPTION TAKEN**

Technical Database  
Page  
1SNK 161 008 D0201  
1SNK 161 008 S0201  
Use  
ation

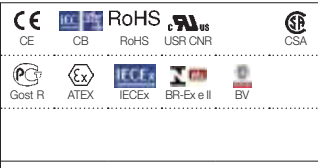

**6 mm 0.236 in spacing**

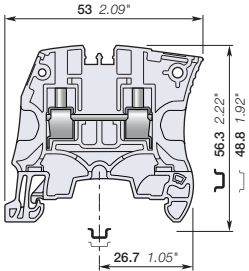

### Features and Benefits

Save space by connecting conductors up to 6 mm<sup>2</sup> 10 AWG in just 6 mm 0.236 in spacing.

### Ordering Details

Description	Color	Type	Order Code	Pack <sup>(n)</sup> pieces	Weight (1 pcs) g
Feed-through	Grey	ZS6	1SNK 506 010 R0000	50	10.64
	Blue	ZS6-BL	1SNK 506 020 R0000	50	10.64
	Orange	ZS6-OR	1SNK 506 030 R0000	50	10.64
	Yellow	ZS6-YL	1SNK 506 060 R0000	50	10.64
	Green	ZS6-GN	1SNK 506 061 R0000	50	10.64
	Red	ZS6-RD	1SNK 506 062 R0000	50	10.64
	Purple	ZS6-PR	1SNK 506 063 R0000	50	10.64
	Brown	ZS6-BR	1SNK 506 064 R0000	50	10.64
	White	ZS6-WH	1SNK 506 065 R0000	50	10.64
	Black	ZS6-BK	1SNK 506 066 R0000	50	10.64

### Main Technical Data

Connecting capacity	IEC	cULus - CSA
1 conductor per clamp	Rigid : 0.2-6 mm <sup>2</sup>	24-10 AWG
	Flexible : 0.22-6 mm <sup>2</sup>	24-10 AWG
	with non insulated ferrule : 0.22-4 mm <sup>2</sup>	24-12 AWG
	with insulated ferrule : 0.22-4 mm <sup>2</sup>	24-12 AWG
	Gauge : A4-B3	
2 conductors per clamp	Rigid : 0.2-2.5 mm <sup>2</sup>	24-14 AWG
	Flexible : 0.2-2.5 mm <sup>2</sup>	24-14 AWG
	with twin ferrule : 0.22-2.5 mm <sup>2</sup>	24-14 AWG
Rated cross section	6 mm <sup>2</sup>	10 AWG
Rated current	41 A	30 A
Rated short-time withstand current (1s)	720 A	
Rated voltage	1000 V	600 V
Impulse withstand voltage	8000 V	
Protection	IP20	NEMA 1
Rated voltage Ex e	630 V IEC/EN 60079-7 IM2 II 2 GD Ex e I/II	

### Mounting Instructions

Rail		TH 35-7.5, TH 35-15
Wire stripping length		10.5 mm 0.413 in
Tool		Flat screwdriver Ø 4 mm Ø 0.157 in
Torque		0.85 Nm ± 0.15 7.52 lb.in ± 1.33

### Accessories

Description	Color	Type	Order Code	Pack <sup>(n)</sup> pieces	Weight (1 pcs) g
1 End Stops 10 mm 0.394 in	Dark Grey	BAM3	1SNK 900 001 R0000	50	13.80
2 End Sections 2.2 mm 0.087 in	Dark Grey	ES4	1SNK 505 910 R0000	20	2.18
3 Jumper Bars 2 poles 41 A 30 A	Orange	JB6-2	1SNK 906 302 R0000	50	1.30
		JB6-3	1SNK 906 303 R0000	50	2.10
		JB6-4	1SNK 906 304 R0000	50	2.90
		JB6-5	1SNK 906 305 R0000	50	3.60
		JB6-10	1SNK 906 310 R0000	20	7.40
		JB6-50	1SNK 906 350 R0000	10	38.10
4 Circuit Separators 0 mm 0 in	Dark Grey	CS	1SNK 900 101 R0000	20	0.20
		CS-R1	1SNK 900 103 R0000	20	5.20
5 Test Adapters For test plugs DIA 2 mm 0.079 in	Dark Grey	TP2	1SNK 900 203 R0000	20	1.73
		TP4	1SNK 900 205 R0000	20	2.42
6 Test Connectors End module, 5.2 mm 0.205 in	Dark Grey	TC5-R1	1SNK 900 201 R0000	10	5.23
7 Spacers 0.8 mm 0.031 in spacing	Dark Grey	ES-TC6	1SNK 900 105 R0000	10	0.80
8 Shield Connectors		SHBS	1SNK 900 600 R0000	20	3.50
9 Protecting Covers 6 mm 0.236 in spacing	Transparent	PL6	1SNK 900 619 R0000	10	1.84
10 Terminal Block Markers	White	MC612	1SNK 150 000 R0000	22	10.00
		MC612PA	1SNK 159 999 R0000	20	11.00
	Universal wire markers holder	Grey	UMH	1SNK 900 611 R0000	10
	White	SAT6	1SNK 900 615 R0000	5	6.00

Some accessories may modify the terminal block's ratings. See complete information in "Technical Datasheet".



### Ground Screw Clamp Terminal Blocks

Description	Color	Type	Order Code	Pack <sup>(n)</sup> pieces	Weight (1 pcs) g
Ground Profile aligned with ZS6	Green-Yellow	ZS6-PE	1SNK 506 150 R0000	20	13.70

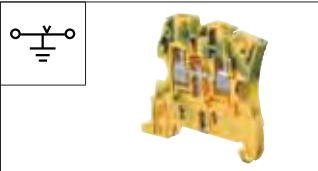

All the technical data for UL/CSA standard and dimensions in inches are in *italics*.

# ZS4-SF1 Screw Clamp Terminal Blocks for 5x20 and 5x25 Fuses

SUBMITTAL Use  
Technical Datasheet 1SNK 161 011 D0201  
Page 1 1SNK 161 011 S0201

**STANTEC**  
**THIS PAGE ONLY**  
**NO EXCEPTION TAKEN**

4 mm<sup>2</sup>  
10 AWG

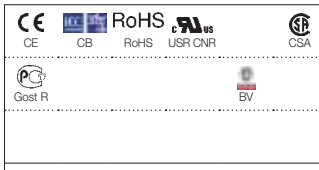

8 mm 0.315 in spacing

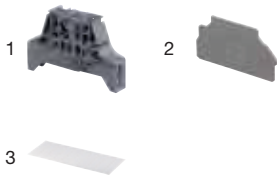
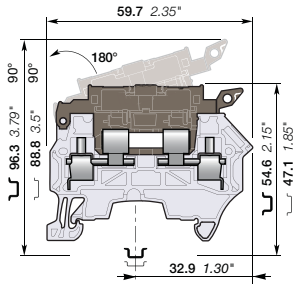

## Features and Benefits

- Protect your circuit with 5x25 and 5x20 fuse terminal blocks, compliant with IEC 60947-7-3 standard (fuse not supplied with the terminal blocks).

## Ordering Details

Description	Color	Type	Order Code	Pack <sup>(ing)</sup> pieces	Weight (1 pc) g
	Grey-Dark Grey	ZS4-SF1	1SNK 508 410 R0000	50	13.30

## Main Technical Data

Connecting capacity	IEC	cULus - CSA
1 conductor per clamp	Rigid : 0.2-4 mm <sup>2</sup>	24-10 AWG
	Flexible : 0.22-4 mm <sup>2</sup>	24-10 AWG
	with non insulated ferrule : 0.22-4 mm <sup>2</sup>	24-12 AWG
	with insulated ferrule : 0.22-4 mm <sup>2</sup>	24-12 AWG
	Gauge : A3-B3	
2 conductors per clamp	Rigid : 0.2-1.5 mm <sup>2</sup>	24-16 AWG
	Flexible : 0.2-1.5 mm <sup>2</sup>	24-16 AWG
	with twin ferrule : 0.22-1.5 mm <sup>2</sup>	24-16 AWG
Rated cross section	4 mm <sup>2</sup>	10 AWG
Rated current	6.3 A	6.3 A
Rated short-time withstand current (1s)	480 A	
Rated voltage	250 V	300 V
Impulse withstand voltage	8000 V	
Protection	IP20	NEMA 1
Rated power		
Separate arrangement/Overload and short-circuit protection	2.5 W	
Separate arrangement/Exclusive short-circuit protection	4 W	
Compound arrangement/Overload and short-circuit protection	1.6 W	
Compound arrangement/Exclusive short-circuit protection	4 W	

## Mounting Instructions

Rail		TH 35-7.5, TH 35-15
Wire stripping length		11 mm 0.433 in
Tool		Flat screwdriver Ø 3.5 mm Ø 0.138 in
Torque		0.6 Nm ± 0.1 5.31 lb.in ± 0.885

## Accessories

Description	Color	Type	Order Code	Pack <sup>(ing)</sup> pieces	Weight (1 pc) g
1 End Stops 10 mm 0.394 in	Dark Grey	BAM3	1SNK 900 001 R0000	50	13.80
2 End Sections 1.5 mm 0.059 in	Dark Grey	ES4-SF	1SNK 508 960 R0000	20	1.82
3 Terminal Block Markers	White	MC812	1SNK 169 999 R0000	20	14.00
		MC812PA	1SNK 169 999 R0000	20	14.00
	Grey	UMH	1SNK 900 611 R0000	10	0.20
	White	SAT8	1SNK 900 616 R0000	5	6.00

Some accessories may modify the terminal block's ratings. See complete information in "Technical Datasheet".

# Modular Pilot devices

**ABB**

Modular Range  
General information

**STANTEC**  
**THIS PAGE ONLY**  
**NO EXCEPTION TAKEN**

SUBMITTAL  
Do Not Use  
For Installation



7

## General construction

- Snap-on feature reduces installation time
- Bezels: Black plastic, chrome metal. Grey plastic available as an option
- Contact block holder features rear mounting with quick-release locking mechanism for high security
- Buttons available in several colors
- Engraved text caps available
- Custom-specific markings on request
- UL File# E76003
- CSA File# LR19700

## Operators

- Pushbuttons, illuminated and non-illuminated
- Double pushbuttons, illuminated and non-illuminated
- Mushroom pushbuttons, illuminated and non-illuminated, Ø 40 mm and Ø 60 mm
- Emergency stop pushbuttons, illuminated and non-illuminated, twist or pull release
- Selector switches, illuminated and non-illuminated, 2 or 3 position, short or long handle
- Key operated selector switches, 2 or 3 position
- Toggle switches, 2 or 3 position
- Joy sticks
- Extreme duty pushbuttons

## Pilot lights

- Full voltage, resistor and transformer
- LED & filament bulbs available for illuminated pushbuttons and pilot lights

## Contact blocks

- Quick-mount, quick-release contact block holder for fast and easy assembly
- NO & NC contact blocks are color coded for easy identification: Green = NO, Red = NC
- Silver tipped contacts
- Wiping action for high reliability
- Low energy gold plated contact blocks
- Base mounted contact blocks which snap onto a 35 mm DIN rail or into a plastic enclosure
- Contact block holder for three or five blocks in a single row

## Additional products

- Buzzer, continuous and pulsating
- 5 k $\Omega$  and 10 k $\Omega$  potentiometers
- Definite purpose pushbuttons
- Reset pushbuttons
- Broad range of accessories

## Catalog number explanation

### Modular pilot devices

**STANTEC**  
**THIS PAGE ONLY**  
**NO EXCEPTION TAKEN**

### Pilot light

Example 1: Type ML1-100R

**L1** Pilot Light Head

**Lens color:**  
**R** = Red  
**G** = Green  
**Y** = Yellow  
**L** = Blue  
**W** = White  
**C** = Clear

### Operators

7 Example 2: Type MP1-10Y

**P** Pushbutton  
**PD** Pushbutton, **D**ouble  
**PK** Pushbutton, **K**ey-lockable  
**PM** Pushbutton, **M**ushroom  
**PMT** Pushbutton, **M**ushroom, **T**wist release  
**PMP** Pushbutton, **M**ushroom, **P**ull release  
**2SS** 2-pos, **S**elector **S**witch  
**3SS** 3-pos, **S**elector **S**witch  
**KB** **B**uzzer  
**KT** **P**otentiometer  
**TS** **T**oggle **S**witch

**Button color:**  
**R** = Red  
**G** = Green  
**Y** = Yellow  
**L** = Blue  
**W** = White  
**B** = **B**lack (non-illuminated only)  
**C** = Clear  
**U** = **G**rey (non-illuminated only)

**Lens color for double pushbuttons**  
**R** = Red  
**G** = Green  
**Y** = Yellow  
**C** = Clear  
**B** = **B**lack (non-illuminated only)  
**-**

Example 3: Type M2SSK1-101

**2SSK** 2-pos. **S**elector **S**witch, **K**ey-lockable  
**3SSK** 3-pos. **S**elector **S**witch, **K**ey-lockable  
**PK** Pushbutton, **K**ey-lockable

**Key code:**  
**1** = **71**  
**2** = **72**  
**3** = **73**

### Buzzer, contact blocks, lamp blocks

Example 4: Type MCBH-10

**B** **B**uzzer  
**CB** **C**ontact **B**lock  
**CBH** **C**ontact **B**lock with **H**older  
**LB** **L**amp **B**lock

**Contact blocks:**  
**10** = 1NO  
**01** = 1NC  
**11** = 1 NO + 1NC  
**02** = 2 NO  
**20** = 2 NC

**M** = "Generation" M, Modular Range

# Flush and extended pushbuttons

Non-illuminated, momentary and maintained

STANTEC  
THIS PAGE ONLY  
NO EXCEPTION TAKEN

SUBMITTAL  
Do Not Use  
Installation  
Pilot Devices  
Modular Range  
Components, 22mm

### How to order:

- Alt.1**
- Operator
  - + Holder
  - + Contact block(s)

- Alt.2**
- Operator
  - + Holder with Contact block(s)

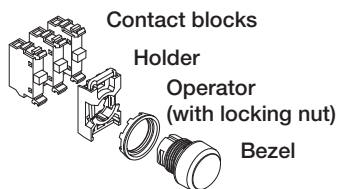

NOTE: For contact blocks & holders, see Accessories page 7.26

### Bezel - How to order

- Black plastic - Standard
- Chrome plastic - Replace '1' with '2' in Catalog number
- Chrome metal - Replace '1' with '3' in Catalog number



Bezel options	Catalog number
Black plastic	MPX-10X
Chrome metal	MPX-30X

### Operator: pushbutton



Non-illuminated flush pushbutton with black plastic bezel

Description	Catalog number	Weight oz.
<b>Flush pushbutton</b>		
<b>Momentary</b>		
Red	MP1-10R	0.56
Green	MP1-10G	0.56
Yellow	MP1-10Y	0.56
Blue	MP1-10L	0.56
White	MP1-10W	0.56
Black	MP1-10B	0.56
Clear	MP1-10C	0.56
<b>Maintained</b>		
Red	MP2-10R	0.56
Green	MP2-10G	0.56
Yellow	MP2-10Y	0.56
Blue	MP2-10L	0.56
White	MP2-10W	0.56
Black	MP2-10B	0.56
Clear	MP2-10C	0.56



Non-illuminated extended pushbutton with black plastic bezel

Description	Catalog number	Weight oz.
<b>Extended pushbutton</b>		
<b>Momentary</b>		
Red	MP3-10R	0.56
Green	MP3-10G	0.56
Yellow	MP3-10Y	0.56
Blue	MP3-10L	0.56
White	MP3-10W	0.56
Black	MP3-10B	0.56
Clear	MP3-10C	0.56
<b>Maintained</b>		
Red	MP4-10R	0.56
Green	MP4-10G	0.56
Yellow	MP4-10Y	0.56
Blue	MP4-10L	0.56
White	MP4-10W	0.56
Black	MP4-10B	0.56
Clear	MP4-10C	0.56

# Selector switches

## Two position, non-illuminated

**STANTEC** Pilot Devices  
 Do Not Use  
 Installation  
 Components, 22mm  
**THIS PAGE ONLY**  
**NO EXCEPTION TAKEN**

**How to order:**

**Alt.1** • Operator  
 + Holder  
 + Contact block(s)

**Alt.2** • Operator  
 + Holder with Contact block(s)

Contact blocks  
 Holder  
 Operator (with Locking Nut)  
 Bezel

NOTE: No contact block in center position  
 For contact blocks & holders, see Accessories pages 7.26.

**Bezel - How to order**

Black plastic - Standard  
 Chrome metal - Replace '1' with '3' in Catalog number

Bezel options	Catalog number
Black plastic	M2SS(X)-10X
Chrome metal	M2SS(X)-30X



Selector switch, short handle



Selector switch, long handle

### Operator: Two-position Selector Switch

Description	Catalog number	Weight oz.	
<b>Short handle</b>			
<b>Maintained</b>			
	Red	M2SS1-10R	0.53
	Black	M2SS1-10B	0.53
	Grey	M2SS1-10U	0.53
<b>Maintained</b>			
	Red	M2SS2-10R	0.53
	Black	M2SS2-10B	0.53
	Grey	M2SS2-10U	0.53
<b>Momentary, spring return from C to B</b>			
	Red	M2SS3-10R	0.53
	Black	M2SS3-10B	0.53
	Grey	M2SS3-10U	0.53
<b>Long handle</b>			
<b>Maintained</b>			
	Red	M2SS4-10R	0.63
	Black	M2SS4-10B	0.63
	Grey	M2SS4-10U	0.63
<b>Maintained</b>			
	Red	M2SS5-10R	0.63
	Black	M2SS5-10B	0.63
	Grey	M2SS5-10U	0.63
<b>Momentary, spring return from C to B</b>			
	Red	M2SS6-10R	0.63
	Black	M2SS6-10B	0.63
	Grey	M2SS6-10U	0.63

### Contacts actuated

Handle position	Left block	Right block
	<input type="checkbox"/>	<input type="checkbox"/>
	<input type="checkbox"/>	<input type="checkbox"/>
	<input checked="" type="checkbox"/>	<input checked="" type="checkbox"/>

Not actuated  
 Actuated

## Twist, pull or key release operators Non-illuminated and illuminated 30mm & 40mm head

**STANTEC**  
**THIS PAGE ONLY**  
**NO EXCEPTION TAKEN**

### How to order non-illuminated:

- Alt.1** • Operator  
+ Holder  
+ Contact block(s)
- Alt.2** • Operator  
+ Holder with Contact block(s)

### How to order illuminated:

- Alt.1** • Operator  
+ Holder  
+ Contact block(s)  
+ LED/lamp block
- Alt.2** • Operator  
+ Holder with Contact block(s)  
and LED/lamp block

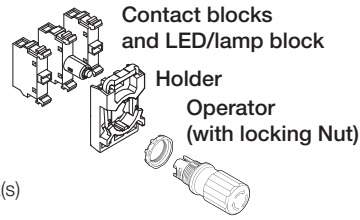

NOTE: For contact blocks, holders & LED lamp blocks, see Accessories pages 7.25 - 7.30.

7



Pull release, Ø 30 mm



Key release, Ø 30 mm

### Operator: Push pull or twist release

Description	Catalog number	Weight oz.
<b>Non-illuminated</b>		
Ø 30 mm		
Black Twist release	MPET3-10B	1.3
Black Pull release	MPEP3-10B	1.3
Red Pull release	MPEP3-10R	1.3
Black Key release code 71/Ronis 455	MPEK3-11B	1.3
Ø 40 mm		
Black Twist release	MPET4-10B	1.3
Black Pull release	MPEP4-10B	1.3
Red Pull release	MPEP4-10R	1.3
Black Key release code 71/Ronis 455	MPEK4-11B	1.3
Ø 60 mm		
Red Pull release	MPMP4-11R	1.7
<b>Illuminated</b>		
Ø 40 mm		
Red Pull release	MPMP3-11R	1.4
Ø 60 mm		
Red Pull release	MPMP4-11R	1.7

To comply with the standard, IEC 60947-5-5, a number of tests have to be conducted:

<b>Durability test</b>	6,050 cycles. This is not a test of mechanical life. The product has a mechanical life of 100,000 operations.	<b>Latching test</b>	Impulse voltage test at 2,500 V
<b>Robustness</b>	The force 113 N applied in three axes	<b>Resetting test</b>	Pulling force < 50 N Turning torque < 1 Nm
<b>Conditioning</b>	Heat and cold, moist atmosphere, and in 5 % NaCl	<b>Shock</b>	15 g shock
		<b>Vibration</b>	2 h at 50m/s <sup>2</sup>
		<b>Contacts with positive opening operation</b>	15 g shock



Twist release, Ø 40 mm

## Pilot lights

**STANTEC**  
**THIS PAGE ONLY**  
**NO EXCEPTION TAKEN**

SUBMITTAL  
Do Not Use  
For Installation

### How to order:

**Alt.1** • Indicator  
+ Holder  
+ LED/lamp block

**Alt.2** • Indicator  
+ Holder  
+ LED/lamp block  
+ Lens: used together with LED to improve light diffusion (Cannot be used together with Text Cap)

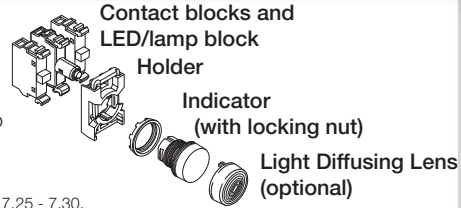

For contact blocks, holders & LED lamp blocks, see Accessories pages 7.25 - 7.30.

### Indicator: Pilot light



Pilot light

Description	Catalog number	Weight oz.
<b>Pilot lights</b>		
Red	ML1-100R	0.63
Green	ML1-100G	0.63
Yellow	ML1-100Y	0.63
Blue	ML1-100L	0.63
White	ML1-100W	0.63
Clear	ML1-100C	0.63

**Note:** Bulbs, lamp blocks & LED blocks are not included – See Accessories page 7.27.

### Accessories

Light diffusing lens	KA1-8005	0.035
----------------------	----------	-------

**Note:** Light diffusing lens is used to improve illumination of LED bulbs. Cannot be used together with text cap.



Light diffusing lens

# Accessories

## LED blocks, front mounting

**STANTEC** Pilot Devices  
 Do Not Use  
 Installation  
 Components, 22mm  
**THIS PAGE ONLY**  
**NO EXCEPTION TAKEN**



LED block with built in leakage current protection

Description	Rated Current mA	Wavelength nm	Luminance mcd	Catalog number	Weight oz.
-------------	------------------	---------------	---------------	----------------	------------

### LED-blocks

Lamp block with one diode chip integrated into lamp block. Choose the same color for the LED and the lamp cap or else use a clear cap.

#### Rated voltage 12 V, DC

Red	12.0	620	320	MLBL-00R	0.42
Green	9.3	520	1500	MLBL-00G	0.42
Yellow	12.0	588	380	MLBL-00Y	0.42
Blue	9.5	468	450	MLBL-00L	0.42
White	9.3	<sup>2)</sup>	600	MLBL-00W	0.42

#### Rated voltage 24 V, AC/DC

Red	9.9	620	250	MLBL-01R	0.42
Green	9.2	520	1500	MLBL-01G	0.42
Yellow	9.9	588	250	MLBL-01Y	0.42
Blue	9.3	468	450	MLBL-01L	0.42
White	9.2	<sup>2)</sup>	600	MLBL-01W	0.42

#### Rated voltage 48 V, AC/DC

Red	10.0	620	260	MLBL-02R	0.42
Green	9.7	520	1500	MLBL-02G	0.42
Yellow	10.0	588	300	MLBL-02Y	0.42
Blue	9.7	468	450	MLBL-02L	0.42
White	9.7	<sup>1)</sup>	600	MLBL-02W	0.42

#### Rated voltage 60 V, AC/DC

Red	13.0	620	350	MLBL-03R	0.42
Green	12.7	520	2000	MLBL-03G	0.42
Yellow	13.0	588	400	MLBL-03Y	0.42
Blue	12.7	468	550	MLBL-03L	0.42
White	12.7	<sup>1)</sup>	750	MLBL-03W	0.42

#### Rated voltage 110-130 V, AC

Red	8.6	620	200	MLBL-04R	0.42
Green	8.5	520	1200	MLBL-04G	0.42
Yellow	8.6	588	250	MLBL-04Y	0.42
Blue	7.0	468	400	MLBL-04L	0.42
White	7.0	<sup>1)</sup>	500	MLBL-04W	0.42

#### Rated voltage 110-130 v, DC

Red	9.9	620	250	MLBL-05R	0.42
Green	9.8	520	1500	MLBL-05G	0.42
Yellow	9.9	588	300	MLBL-05Y	0.42
Blue	9.8	468	450	MLBL-05L	0.42
White	9,8	<sup>1)</sup>	600	MLBL-05W	0.42

#### Rated voltage 220 V, DC

Red	8.0	620	180	MLBL-06R	0.42
Green	8.0	520	110	MLBL-06G	0.42
Yellow	8.0	588	200	MLBL-06Y	0.42
Blue	8.0	468	450	MLBL-06L	0.42
White	8.0	<sup>1)</sup>	600	MLBL-06W	0.42

#### Rated voltage 230 V, AC

Red	9.5	620	250	MLBL-07R	0.42
Green	9.4	520	1500	MLBL-07G	0.42
Yellow	9.5	588	300	MLBL-07Y	0.42
Blue	8.2	468	450	MLBL-07L	0.42
White	8.2	<sup>1)</sup>	600	MLBL-07W	0.42

Note: Care should be taken for DC supply where + and - must be correctly connected. This is marked X1 (+) and X2 (-) on the product.

<sup>1)</sup> X=0.31, Y=0.32 according to the ICI Chromaticity Diagram.

## Accessories

### Contact blocks and holders

**STANTEC**  
**THIS PAGE ONLY**  
**NO EXCEPTION TAKEN**

SUBMITTAL  
Do Not Use  
For Installation



Holders for contact block

Description	Catalog number	Weight oz.
<b>Holders</b>		
Holders for three blocks	MCBH-00	0.21
Holders for five blocks*	MCBH5-00	0.28

\* Note: Double contact blocks are required on side positions

<b>Single contact blocks for front mounting</b>		
1 NO	MCB-10	0.46
1 NC	MCB-01	0.46
1 NO w/gold plated contacts	MCB-10C	0.46
1 NC w/gold plated contacts	MCB-01G	0.46

#### Micro switch blocks

1 NO	MCBL-10	0.35
1 NC	MCBL-01	0.35

#### Double contact block for front mounting

2 NO	MCB-20	0.92
2 NC	MCB-02	0.92
1 NO + 1 NC	MCB-11	0.92
2NC w/gold plated contacts	MCB-02G	0.92
2NO w/gold plated contacts	MCB-20G	0.92

Note: To be used together with MCBH5-00 when Contact blocks in position 4- and 5- are needed. Also when using 2nd lamp blocks MCBH-00 together with Selector Switch and Contact block in position 3- is needed

#### Contact blocks with holder for front mounting ①

For non-illuminated operators

1 NC	MCBH-01
1 NO	MCBH-10
2 NC	MCBH-02
2 NO	MCBH-20
3 NC	MCBH-03
3 NO	MCBH-30
1 NO + 1 NC	MCBH-11
1 NO + 2 NC	MCBH-12
2 NO + 1 NC	MCBH-21

For illuminated operator

1 LB	MCBH-001
1 NC + 1 LB	MCBH-011
1 NO + 1 LB	MCBH-101
1 NO + 1 NC + 1 LB	MCBH-111
2 NO & 1 LB	MCBH-021
2 NO & 1 LB	MCBH-201

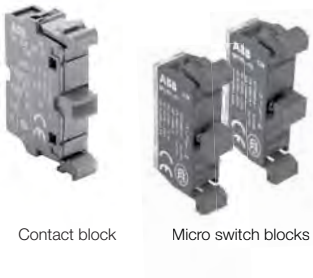

Contact block

Micro switch blocks



Double contact blocks

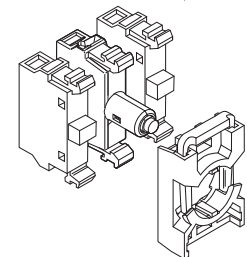
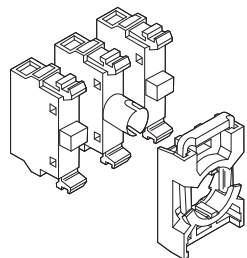
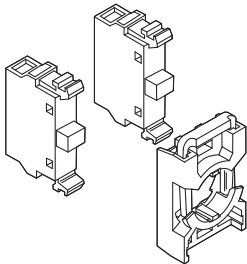

Products → Low Voltage Products and Systems → Control Products → Power Supplies

Products → Power Automation Products → Remote Terminal Units → RTU500 series modules  
→ RTU500 series power supply units

## General Information

Extended Product Type:	CP-E 24/2.5
Product ID:	1SVR427032R0000
EAN:	4016779656887
Catalog Description:	CP-E 24/2.5 Power supply In:100-240VAC Out: 24VDC/2.5A
Long Description:	The CP-E 24/2.5 is a power supply from the CP-E range. The primary switch mode power supply offers a wide range input of 85-264 V AC and 90-375 V DC, rated input voltage is 100-240 V AC. The rated output power is 60 W, rated output current is 2.5 A at an output voltage of 24 V DC. The output voltage is adjustable within a range of 24 to 28 V DC. The power supply provides a U/I output characteristic and allows parallel operation to enable redundancy. A further feature is the signalling output (transistor) for output voltage OK. A redundancy unit is available as accessory.

## Ordering

Minimum Order Quantity:	1 piece
Customs Tariff Number:	85044090

## Popular Downloads

Data Sheet, Technical Information:	2CDC114045D0201
Instructions and Manuals:	1SVC427031M0000

## Dimensions

Product Net Width:	40.5 mm
Product Net Height:	90 mm
Product Net Depth:	114 mm
Product Net Weight:	0.331 kg

## Container Information

Package Level 1 Width:	132 mm
Package Level 1 Length:	154 mm
Package Level 1 Height:	58 mm
Package Level 1 Gross Weight:	0.4 kg
Package Level 1 EAN:	4016779656887
Package Level 1 Units:	1 piece

## Technical

SUBMITTAL  
Do Not Use  
For Installation

**STANTEC**

**THIS PAGE ONLY  
NO EXCEPTION TAKEN**

Function:	Switch mode power supply
Number of Phases:	1
Rated Input Voltage (U <sub>IN</sub> ):	100 ... 240 V AC
Input Voltage (U <sub>in</sub> ):	85 ... 264 V AC 90 ... 375 V DC
Rated Frequency Limits:	47 ... 63 Hz
Characteristic of Output:	U/I characteristic curve
Rated Output Power:	60 W
Output Power:	60 W
Rated Output Voltage:	24 V DC
Output Voltage (U <sub>out</sub> ):	24 V DC
Rated Output Current:	2.5 A
Output Current:	2.5 A
Rated Insulation Voltage (U <sub>i</sub> ):	Input Circuit / Output Circuit 3 V Input Circuit / PE 2 V
Degree of Protection:	Housing IP20 Terminals IP20
Pollution Degree:	2
Connecting Capacity Input Circuit:	Flexible with Ferrule 0.2 ... 2.5 mm <sup>2</sup> Rigid 0.2 ... 2.5 mm <sup>2</sup>
Connecting Capacity Output Circuit:	Flexible with Ferrule 0.2 ... 2.5 mm <sup>2</sup> Rigid 0.2 ... 2.5 mm <sup>2</sup>
Tightening Torque:	Input Circuit 0.6 N·m Output Circuit 0.6 N·m
Wire Stripping Length:	Input Circuit 6 mm Output Circuit 6 mm
Minimum Mounting Distance:	Electrical Conductive Board, Horizontal 25 mm Electrical Conductive Board, Vertical 25 mm Other Device Same Type, Horizontal 25 mm Other Device Same Type, Vertical 25 mm
Mounting Position:	Position 1
Mounting on DIN Rail:	TH35-7.5 (35 x 7.5 mm Mounting Rail) acc. to IEC 60715 TH35-15 (35 x 15 mm Mounting Rail) acc. to IEC 60715

Standards:	EN 50581
	IEC/EN 60950-1
	IEC/EN 61000-6-2
	IEC/EN 61000-6-3
	UL 508
	UL 60950
	UL 1310
	ANSI/ISA-12.12
	CAN/CSA C22.2 No.107.1
	CAN/CSA C22.2 No.213
	CAN/CSA C22.2 No.60950
	CAN/CSA C22.2 No.223

**STANTEC**  
**THIS PAGE ONLY**  
**NO EXCEPTION TAKEN**

SUBMITTAL  
Do Not Use  
For Installation

## Environmental

Ambient Air Temperature:	Operation -40 ... +70 °C Storage -40 ... +85 °C
--------------------------	--

RoHS Status:	Following EU Directive 2011/65/EU
--------------	-----------------------------------

## Technical UL/CSA

Connecting Capacity Input Circuit UL/CSA:	Rigid 24-14 AWG
--	-----------------

Connecting Capacity Output Circuit UL/CSA:	Rigid 24-14 AWG
---	-----------------

Tightening Torque UL/CSA:	Input Circuit 5 in-lb Output Circuit 5 in-lb
---------------------------	---

## Electromagnetic Compatibility

Electrostatic Discharge (ESD Immunity) acc. to IEC 61000-4-2:	Level 4 Air Discharge 15 kV Level 4 Contact Discharge 8 kV
--	---

Radiated Electromagnetic Field Immunity acc. to IEC 61000-4-3:	Level 3 10 V/m
---	----------------

Electrical Fast Transient (Burst Immunity) acc. to IEC 61000-4-4:	Level 4 Power Supply Port Signal 4 kV
--	---------------------------------------

Surge Immunity acc. to IEC 61000- 4-5:	Level 3 Line-to-Line 2 kV Level 4 Line-to-Ground 4 kV
---	--

Conducted Disturbances Immunity acc. to IEC 61000-4-6:	Level 3 10 V
---	--------------

Electromagnetic Compatibility (EMC):	Immunity - Class B Emission - Class B
---	--

## Certificates and Declarations (Document Number)

CCC Certificate:	CCC_2008010907282731
------------------	----------------------

cUL Certificate:	cUL508_E174460
------------------	----------------

cUR Certificate: cUR60950\_E196145  
cUR1310\_E313203  
cUR\_ANSI\_E317914

**STANTEC**  
**THIS PAGE ONLY**  
**NO EXCEPTION TAKEN**

SUBMITTAL  
Do Not Use  
For Installation

Declaration of Conformity - CE: 1SVD982008-0001

EAC Certificate: EAC\_RU\_C-DE.ME77.B.01651

Environmental Information: 1SAA981005-2406

Instructions and Manuals: 1SVC427031M0000

RoHS Information: 1SVD982008-0001

UL Certificate: UL508\_E174460

UR Certificate: UR60950\_E196145  
UR1310\_E313203  
UR\_ANSI\_E317914

## Classifications

Object Classification Code: T

E-nummer: 5218703

ETIM 4: EC002540 - DC-power supply

ETIM 5: EC002540 - DC-power supply

ETIM 6: EC002540 - DC-power supply

ETIM 7: EC002540 - DC-power supply

eClass: 7.0 27049002

UNSPSC: 39121004





### Main

Range of product	Magelis GTO
Product or component type	Advanced touchscreen panel
Display colour	65536 colours
Display size	12.1 inch
Supply	External source
Operating system	Magelis
Battery type	Lithium battery for internal RAM, autonomy: 100 days, charging time = 5 d, battery life = 10 yr

### Complementary

Terminal type	Touchscreen display
Display type	Backlit colour TFT LCD
Display resolution	800 x 600 pixels SVGA
Touch sensitive zone	1024 x 1024
Touch panel	Resistive film, 1000000 cycles
Backlight lifespan	50000 hours (white) at 25 °C
Brightness	16 levels - control by touch panel 16 levels - control by software
Character font	ASCII (European characters) Chinese (simplified Chinese) Japanese (ANK, Kanji) Korean Taiwanese (traditional Chinese)
[Us] rated supply voltage	24 V DC
Supply voltage limits	19.2...28.8 V
Inrush current	<= 30 A
Power consumption in W	<= 17 W <= 12 W (when power is not supplied to external devices) <= 7 W (when backlight is OFF) <= 8 W (when backlight is dimmed)
Local signalling	Status LED (orange) flashing software starting up

Disclaimer: This documentation is not intended as a substitute for and is not to be used for determining suitability or reliability of these products for specific user applications.

**STANTEC**  
**THIS PAGE ONLY**  
**NO EXCEPTION TAKEN**

Status LED (green) steady offline  
 Status LED (green) steady operating  
 Status LED (red) steady power supply (ON)  
 Status LED (clear) faded power supply (OFF)  
 COM2 LED (yellow) steady data is being transmitted  
 COM2 LED (yellow) faded no data transmission  
 SD card LED (green) steady card is inserted  
 SD card LED (green) faded card is not inserted or is not being accessed

Software designation	Vijeo Designer configuration software >= V6.1
Memory description	96 MB flash (EPROM)
Data backed up	512 kB internal RAM (SRAM)
Data storage equipment	SD card <= 32 GB SDHC card <= 32 GB
Downloadable protocols	Modbus Plus Schneider Electric Modicon FIPWAY Schneider Electric Modicon Modbus TCP Schneider Electric Modicon Modbus Schneider Electric Modicon Third party protocols Mitsubishi Melsec Third party protocols Omron Sysmac Third party protocols Rockwell Automation Allen-Bradley Third party protocols Siemens Simatic Uni-TE Schneider Electric Modicon
Integrated connection type	COM1 serial link SUB-D 9, interface: RS232C, transmission rate: 2400...115200 bps COM2 serial link RJ45, interface: RS485, transmission rate: 2400...115200 bps COM2 serial link RJ45, interface: RS485, transmission rate: 187.5 kbps compatible with Siemens MPI Ethernet RJ45, interface: 10BASE-T/100BASE-TX Ethernet RJ45, interface: IEEE 802.3 USB 2.0 type A USB 2.0 type mini B
Product mounting	Flush mounting
Fixing mode	By 4 screw clamps
Front material	PPT
Enclosure material	PPT
Type of cooling	Natural convection
Width	315 mm
Height	241 mm
Depth	56 mm
Product weight	2.5 kg

## Environment

Standards	EN 61131-2 IEC 61000-6-2 UL 508
Product certifications	CE C-Tick cULus KCC
Ambient air temperature for operation	0...55 °C
Ambient air temperature for storage	-20...60 °C
Relative humidity	10...90 % without condensation
Operating altitude	< 2000 m
IP degree of protection	IP20 rear panel conforming to IEC 60529 IP65 front panel conforming to IEC 60529
NEMA degree of protection	NEMA 4X front panel (indoor use)
Shock resistance	147 m/s <sup>2</sup> 3 chocks in each direction X, Y and Z conforming to EN/IEC 61131-2
Vibration resistance	3.5 mm (f = 5...9 Hz) conforming to EN/IEC 61131-2 X, Y, Z directions for 10 cycles (approx. 100 min) 1 gn (f = 9...150 Hz) conforming to EN/IEC 61131-2 X, Y, Z directions for 10 cycles (approx. 100 min)
Resistance to electrostatic discharge	6 kV contact discharge conforming to IEC 61000-4-2 level 3

**STANTEC**  
**THIS PAGE ONLY**

**NO EXCEPTION TAKEN**

### Offer Sustainability

Sustainable offer status	Green Premium product
RoHS (date code: YYWW)	Compliant - since 1348 - Schneider Electric declaration of conformity <a href="#">Schneider Electric declaration of conformity</a>
REACH	Reference contains SVHC above the threshold - Go to CaP for more details <a href="#">Go to CaP for more details</a>
Product environmental profile	Available <a href="#">Product environmental</a>
Product end of life instructions	Available <a href="#">End of life manual</a>

### Contractual warranty

Warranty period	18 months
-----------------	-----------

**Transient Discriminating Surge Diverter, 50 kA Single Mode – TDS1501SR150 (702404)**

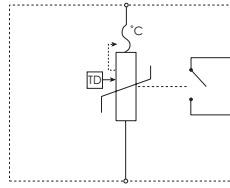
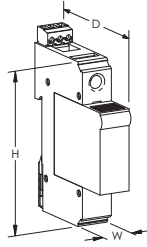

- TD Technology with thermal disconnect protection
- Compact design fits into DIN distribution panel boards and motor control centers
- Indication flags and voltage-free contacts provide remote status monitoring
- Separate plug and base design facilitates replacement of a failed surge module
- 50kA 8/20 $\mu$ s maximum surge rating provides protection suitable for sub-distribution panels and a long operational life



Part Number	TDS1501SR150
Article Number	702404
Nominal System Voltage (Un)	120 - 150 VAC
Max Continuous Operating Voltage (Uc)	170 VAC
Stand-off Voltage	240 VAC
Voltage Protection Rating (VPR)	600 V @ 3 kA 1,000 V @ 25 kA
Nominal Discharge Current (In)	25 kA 8/20 $\mu$ s
Max Discharge Current (Imax)	50 kA 8/20 $\mu$ s
Back-Up Overcurrent Protection	125 A
Short Circuit Current Rating (SCCR)	200 kA
Frequency	0 – 100 Hz
Protection Modes	L-N L-PE N-PE
Technology	TD technology with thermal disconnect
Connection, Solid	#2 Max 35 mm <sup>2</sup> Max
Connection, Stranded	#4 Max 25 mm <sup>2</sup> Max
Mounting	35 mm top hat DIN rail
Enclosure Material	UL <sup>®</sup> 94V-0 thermoplastic
Enclosure Rating	IP 20 NEMA <sup>®</sup> -1
Remote Contacts	Yes
Status Indication	Mechanical flag
Temperature	-40 to 80 °C -40 to 176 °F
Module Width	1 M
Depth (D)	2.68" 68 mm
Height (H)	3.54" 90 mm
Width (W)	0.71" 18 mm
Unit Weight	0.26 lb



**STANTEC**  
**THIS PAGE ONLY**  
**NO EXCEPTION TAKEN**

SUBMITTAL  
Do Not Use  
For Installation

<b>Part Number</b>	<b>TDS1501SR150</b>
	0.12 kg
Certification Details	UL® 1449 Edition 3 Type 2, 20 kA Mode
Complies With	ANSI®/IEEE® C62.41.2-2002 Cat A, Cat B, Cat C IEC® 61643-1 Class II ANSI®/IEEE® C62.41.2-2002 Scenario II, Exposure 2, 50 kA 8/20 µs, 5 kA 10/350 µs
Replacement Module	TDS150M150
Standard Packaging Quantity	1 pc
UPC	78285658531
UNSPSC	39121610
ETIM	EC000941
Certifications	CE cURus

ANSI is a registered trademark of American National Standards Institute. IEC is a registered trademark of the International Electrotechnical Commission. IEEE is a registered trademark of The Institute of Electrical and Electronics Engineers, Inc. NEMA is a registered service mark of National Electrical Manufacturers Association. UL, UR, cUL, cUR, cULus and cURus are registered certification marks of UL LLC.

**WARNING**

ERICO products shall be installed and used only as indicated in ERICO's product instruction sheets and training materials. Instruction sheets are available at [www.erico.com](http://www.erico.com) and from your ERICO customer service representative. Improper installation, misuse, misapplication or other failure to completely follow ERICO's instructions and warnings may cause product malfunction, property damage, serious bodily injury and death.

Copyright © 2014 ERICO International Corporation. All rights reserved.

CADDY, CADWELD, CRITEC, ERICO, ERIFLEX, ERITECH, and LENTON are registered trademarks of ERICO International Corporation.



**THIS PAGE ONLY  
NO EXCEPTION TAKEN**

**General purpose relays  
For socket mounting**

**Type 55.32**

- 2 CO 10 A

**Type 55.33**

- 3 CO 10 A

**Type 55.34**

- 4 CO 7 A

- AC & DC coils
- Lockable test button and mechanical flag indicator as standard on 2 & 4 pole types
- Integral LED and coil suppression options
- 94 series sockets for PCB or 35 mm rail mounting (EN 60715) with Screw, Screwless or Push-in terminals
- Coil Indication and EMC suppression modules
- 99 series and Timer module 86.30 options
- Optional alternative mounting adaptors
- UL Listing (certain relay/socket combinations)
- Cadmium Free contacts
- Contact material options
- European Patent

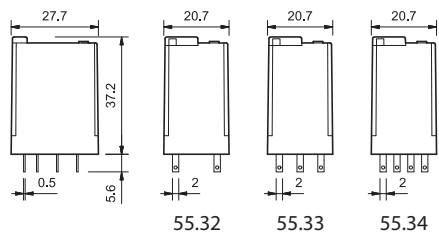

FOR UL RATINGS SEE:

"General technical information" page V

	55.32	55.33	55.34
	<ul style="list-style-type: none"> <li>• 2 CO 10 A</li> <li>• Plug-in 94 series sockets</li> </ul>	<ul style="list-style-type: none"> <li>• 3 CO 10 A</li> <li>• Plug-in 94 series sockets</li> </ul>	<ul style="list-style-type: none"> <li>• 4 CO 7 A</li> <li>• Plug-in 94 series sockets</li> </ul>
<b>Contact specification</b>			
Contact configuration	2 CO (DPDT)	3 CO (3PDT)	4 CO (4PDT)
Rated current/Maximum peak current	A 10/20	10/20	7/15
Rated voltage/Maximum switching voltage	V AC 250/400	250/400	250/250
Rated load AC1	VA 2500	2500	1750
Rated load AC15 (230 V AC)	VA 500	500	350
Single phase motor rating (230 V AC)	kW 0.37	0.37	0.125
Breaking capacity DC1: 30/110/220 V	A 10/0.25/0.12	10/0.25/0.12	7/0.25/0.12
Minimum switching load	mW (V/mA) 300 (5/5)	300 (5/5)	300 (5/5)
Standard contact material	AgNi	AgNi	AgNi
<b>Coil specification</b>			
Nominal voltage (U <sub>N</sub> )	V AC (50/60 Hz)	6 - 12 - 24 - 48 - 60 - 110 - 120 - 230 - 240	
	V DC	6 - 12 - 24 - 48 - 60 - 110 - 125 - 220	
Rated power AC/DC	VA (50 Hz)/W	1.5/1	1.5/1
Operating range	AC	(0.8...1.1)U <sub>N</sub>	(0.8...1.1)U <sub>N</sub>
	DC	(0.8...1.1)U <sub>N</sub>	(0.8...1.1)U <sub>N</sub>
Holding voltage	AC/DC	0.8 U <sub>N</sub> / 0.5 U <sub>N</sub>	0.8 U <sub>N</sub> / 0.5 U <sub>N</sub>
Must drop-out voltage	AC/DC	0.2 U <sub>N</sub> / 0.1 U <sub>N</sub>	0.2 U <sub>N</sub> / 0.1 U <sub>N</sub>
<b>Technical data</b>			
Mechanical life AC/DC	cycles	20 · 10 <sup>6</sup> / 50 · 10 <sup>6</sup>	20 · 10 <sup>6</sup> / 50 · 10 <sup>6</sup>
Electrical life at rated load AC1	cycles	200 · 10 <sup>3</sup>	150 · 10 <sup>3</sup>
Operate/release time	ms	10/5	11/3
Insulation between coil and contacts (1.2/50 μs)	kV	4	4
Dielectric strength between open contacts	V AC	1000	1000
Ambient temperature range	°C	-40...+85	-40...+85
Environmental protection		RT I	RT I
<b>Approvals</b> (according to type)			

**Ordering information**

Example: 55 series plug-in relay, 4 CO, 12 V DC coil, lockable test button and mechanical indicator.

5 5 . 3 4 . 9 . 0 1 2 . 0 0 4 0

**Series** ————

**Type**  
1 = PCB  
3 = Plug-in

**No. of poles**  
2 = 2 pole, 10 A  
3 = 3 pole, 10 A  
4 = 4 pole, 7 A

**Coil version**  
8 = AC (50/60 Hz)  
9 = DC

**Coil voltage**  
See coil specifications

**A: Contact material**  
0 = Standard AgNi  
5 = AgNi + Au

**B: Contact circuit**  
0 = CO (nPDT)

**D: Special versions**  
0 = Standard  
1 = Wash tight (RT III)  
for 55.12, 55.13 and 55.14 only

**C: Options**  
0 = None  
1 = Lockable test button  
2 = Mechanical indicator  
3 = LED (AC)  
4 = Lockable test button + mechanical indicator  
5 = Lockable test button + LED (AC)  
54 = Lockable test button + LED (AC) + mechanical indicator  
6\* = Double LED (DC non-polarized)  
7\* = Lockable test button + double LED (DC non-polarized)  
74\* = Lockable test button + double LED (DC non-polarized) + mechanical indicator  
8\* = LED + diode (DC, polarity positive to pin A1/13)  
9\* = Lockable test button + LED + diode (DC, polarity positive to pin A1/13)  
94\* = Lockable test button + LED + diode (DC, polarity positive to pin A1/13) + mechanical indicator  
\* Options not available for 220 V DC versions.

**Selecting features and options: only combinations in the same row are possible.**  
Preferred selections for best availability are shown in **bold**.

Type	Coil version	A	B	C	D
55.32/34	AC - DC	0 - 5	0	0	0
	AC	<b>0</b> - 5	<b>0</b>	2 - 3 - <b>4</b> - 5	<b>0</b>
	AC	0 - 5	0	54	/
	DC	<b>0</b> - 5	<b>0</b>	2 - <b>4</b> - 6 - 7 - 8 - 9	<b>0</b>
	DC	0 - 5	0	74 - 94	/
55.33	AC - DC	<b>0</b> - 5	<b>0</b>	<b>0</b>	<b>0</b>
	AC	0 - 5	0	1 - 3 - 5	0
	DC	0 - 5	0	1 - 6 - 7 - 8 - 9	0
55.12/13/14	AC - DC	<b>0</b> - 5	<b>0</b>	<b>0</b>	<b>0</b> - 1

**Descriptions: options and special versions**

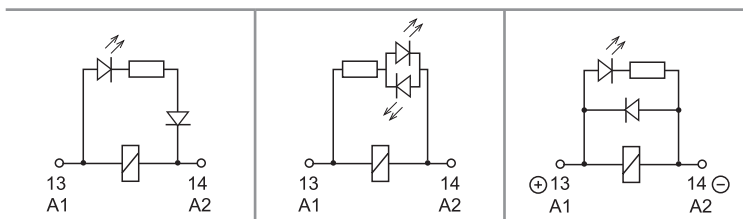

**C: Option 3, 5, 54**  
LED (AC)

**C: Option 6, 7, 74**  
Double LED  
(DC non-polarized)

**C: Option 8, 9, 94**  
LED + diode (DC, polarity positive to pin A1/13)

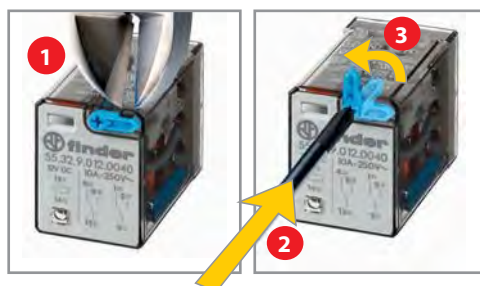

**Lockable test button and mechanical flag indicator (0010, 0040, 0050, 0054, 0070, 0074, 0090, 0094)**



The dual-purpose Finder test button can be used in two ways:

Case 1) The plastic pip (located directly above the test button) remains intact. In this case, when the test button is pushed, the contacts operate. When the test button is released the contacts return to their former state.

Case 2) The plastic pip is broken-off (using an appropriate cutting tool). In this case, (in addition to the above function), when the test button is pushed and rotated, the contacts are latched in the operating state, and remain so until the test button is rotated back to its former position.

In both cases ensure that the test button actuation is swift and decisive.

A



**94.P4**  
See page 7

Module	Socket	Relay	Description	Mounting	Accessories
99.02	94.P3	55.33	<b>Push-in terminal socket</b> - For fast cable connections - Top terminals - Contacts - Bottom terminals - Coil	Panel or 35 mm rail (EN 60715) mount	- Coil indication and EMC suppression modules - Jumper link - Timer modules - Plastic retaining and release clip
	94.P4	55.32 55.34			



**94.04**  
See page 9

Module	Socket	Relay	Description	Mounting	Accessories
99.02	94.02	55.32	<b>Screw terminal (Box clamp) socket</b> - Top terminals - Contacts - Bottom terminals - Coil	Panel or 35 mm rail (EN 60715) mount	- Coil indication and EMC suppression modules - Jumper link - Timer modules - Plastic retaining and release clip
	94.03	55.33			
	94.04	55.32 55.34			

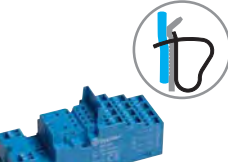

**94.54**  
See page 10

Module	Socket	Relay	Description	Mounting	Accessories
99.02	94.54	55.32 55.34	<b>Screwless terminal socket</b> - Top terminals - Contacts - Bottom terminals - Coil	Panel or 35 mm rail (EN 60715) mount	- Coil indication and EMC suppression modules - Jumper link - Timer modules - Plastic retaining and release clip

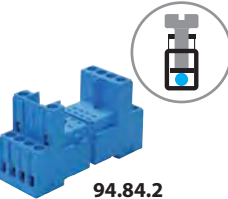

**94.84.2**  
See page 11

Module	Socket	Relay	Description	Mounting	Accessories
99.80	94.84.2	55.32 55.34	<b>Screw terminal (Box clamp) socket</b>	Panel or 35 mm rail (EN 60715) mount	- Coil indication and EMC suppression modules - Jumper link - Plastic retaining and release clip



**94.94.3**  
See page 12

Module	Socket	Relay	Description	Mounting	Accessories
99.80	94.92.3	55.32	<b>Screw terminal (Box clamp) socket</b> - Top terminals - Contacts - Bottom terminals - Coil	Panel or 35 mm rail (EN 60715) mount	- Coil indication and EMC suppression modules - Jumper link - Plastic retaining and release clip
	94.94.3	55.32 55.34			

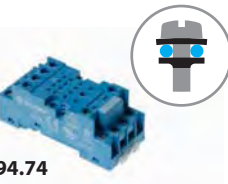

**94.74**  
See page 13

Module	Socket	Relay	Description	Mounting	Accessories
99.01	94.72	55.32	<b>Screw terminal (Plate clamp) socket</b> For 94.82: - 23 mm wide for space saving	Panel or 35 mm rail (EN 60715) mount	- Coil indication and EMC suppression modules - Plastic retaining and release clip
	94.73	55.33			
	94.74	55.32 55.34			
	94.82	55.32			



**94.14**  
See page 14

Module	Socket	Relay	Description	Mounting	Accessories
—	94.12	55.32	<b>PCB socket</b>	PCB mounting	- Metal retaining clip
—	94.13	55.33			
—	94.14	55.32 55.34			



**94.22**  
See page 14

Module	Socket	Relay	Description	Mounting	Accessories
—	94.22	55.32	<b>Panel mount with solder connections</b>	Panel mount on 1 mm thick panel	- Metal retaining clip
—	94.23	55.33			
—	94.24	55.32 55.34			



**94.34**  
See page 15

Module	Socket	Relay	Description	Mounting	Accessories
—	94.32	55.32	<b>Panel mount with solder connections</b>	M3 screw fixing	- Metal retaining clip
—	94.33	55.33			
—	94.34	55.32 55.34			

**THIS PAGE ONLY NO EXCEPTION TAKEN**



94.04

Approvals (according to type):



cUL US Certain relay/socket combinations



094.91.3



060.48

Screw terminal (Box clamp) socket panel or 35 mm (EN 60715) rail mount	94.02 Blue	94.02.0 Black	94.03 Blue	94.03.0 Black	94.04 Blue	94.04.0 Black
For relay type	55.32		55.33		55.32, 55.34	
<b>Accessories</b>						
Metal retaining clip	094.71					
Plastic retaining and release clip (supplied with socket - packaging code SPA)	094.91.3	094.91.30	094.91.3	094.91.30	094.91.3	094.91.30
6-way jumper link	094.06	094.06.0	094.06	094.06.0	094.06	094.06.0
Identification tag	094.00.4					
Marker tag holder	097.00					
Modules (see table below)	99.02					
Timer modules (see table below)	86.30					
Sheet of marker tags for plastic retaining and release clip 094.91.3 and for marker tag holder 097.00, 48 tags, 6 x 12 mm for CEMBRE thermal transfer printers	060.48					
<b>Technical data</b>						
Rated values	10 A - 250 V					
Dielectric strength	2 kV AC					
Protection category	IP 20					
Ambient temperature	°C -40...+70					
⊕ Screw torque	Nm 0.5					
Wire strip length	mm 8					
Max. wire size for 94.02/03/04 sockets	solid wire			stranded wire		
	mm <sup>2</sup> 1 x 6 / 2 x 2.5			1 x 4 / 2 x 2.5		
	AWG 1 x 10 / 2 x 14			1 x 12 / 2 x 14		

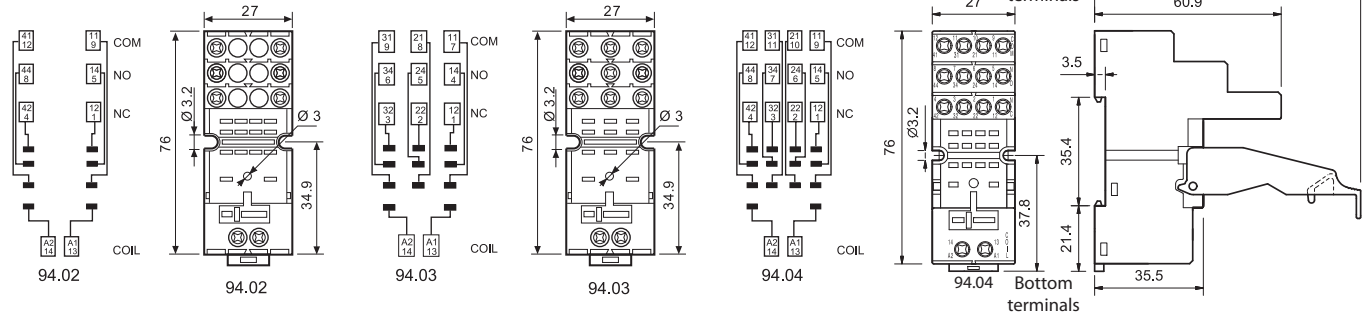

6-way jumper link for 94.02, 94.03 and 94.04 sockets	094.06 (blue)	094.06.0 (black)
	Rated values	10 A - 250 V



86.30

86 series timer modules	
(12...24)V AC/DC; Bi-function: AI, DI; (0.05 s...100 h)	86.30.0.024.0000
(110...125)V AC; Bi-function: AI, DI; (0.05 s...100 h)	86.30.8.120.0000
(230...240)V AC; Bi-function: AI, DI; (0.05 s...100 h)	86.30.8.240.0000

Approvals (according to type): **CE ENEC EAC PG cRU US**



99.02

99.02 coil indication and EMC suppression modules for 94.02, 94.03 and 94.04 sockets		
Diode (+A1, standard polarity)	(6...220)V DC	99.02.3.000.00
LED	(6...24)V DC/AC	99.02.0.024.59
LED	(28...60)V DC/AC	99.02.0.060.59
LED	(110...240)V DC/AC	99.02.0.230.59
LED + Diode (+A1, standard polarity)	(6...24)V DC	99.02.9.024.99
LED + Diode (+A1, standard polarity)	(28...60)V DC	99.02.9.060.99
LED + Diode (+A1, standard polarity)	(110...240)V DC	99.02.9.220.99
LED + Varistor	(6...24)V DC/AC	99.02.0.024.98
LED + Varistor	(28...60)V DC/AC	99.02.0.060.98
LED + Varistor	(110...240)V DC/AC	99.02.0.230.98
RC circuit	(6...24)V DC/AC	99.02.0.024.09
RC circuit	(28...60)V DC/AC	99.02.0.060.09
RC circuit	(110...240)V DC/AC	99.02.0.230.09
Residual current by-pass	(110...240)V AC	99.02.8.230.07

Approvals (according to type):



DC Modules with non-standard polarity (+A2) on request.

# MB-V09-201-S(#)

STANTEC

THIS PAGE ONLY  
NO EXCEPTION TAKEN

Made in  
USA



- Durable Stainless Steel 304 Diaphragm
- Epoxy Encapsulated Electronics
- UL Approved
- NEMA 4X Certified with Optional Gasket
- Reliable Piezoelectric Technology

- (#) Beep Rates Available: (U) - Ultra Fast, 6 beeps per second  
 (F) - Fast, 3 beeps per second  
(M) - Medium, 2 beeps per second  
 (S) - Slow, 1 beep per second

## SPECIFICATIONS

<b>Operating Mode:</b>	Medium Loud Beep Tone
<b>Operating Voltage:</b>	30-120 Vac
<b>Nominal Operating Voltage:</b>	110 Vac
<b>Operating Frequency:</b>	2900±250 Hz.
<b>Typical Operating Current:</b>	5 mA at 30 Vac 20 mA at 120 Vac
<b>Typical Sound Pressure:</b>	With volume control fully open: 85±5 dB(A), at 30 Vac, at 24 inches (61 cm), at 25°C 95±5 dB(A), at 120 Vac, at 24 inches (61 cm), at 25°C.
<b>Termination:</b>	0.25 (6.3) Wide Quick Connect Blades with 0.25 (6.3) Long 6x32 Stainless Steel Screws
<b>Termination Strength:</b>	Pull test with a maximum of 22 pounds (10 kg) load
<b>Operating Temperature:</b>	-20°C to +65°C.
<b>Storage Temperature:</b>	-40°C to +85°C.
<b>Surge Voltage:</b>	20% over maximum rated voltage for less than 5 minutes.
<b>Part Recognized By:</b>	Underwriters Laboratory
<b>Construction Materials:</b>	Case- Plastic "NORYL® N-190", Flame Retardant UL 94-VO, Black Internal Circuit- Audio-oscillator and piezoelectric driver Potting- 2 parts epoxy resin or silicone, black Diaphragm- Stainless Steel 304 Gasket (Sold Separately)— 0.062" Thick, 60 Durometer Neoprene
<b>Environmental Durability:</b>	Salt Spray- Withstand exposure to salt spray per ASTM B117 for a period of 300 hours with no decrease in sound output Humidity- 95% relative humidity at +40°C continuously for 100 hours. Vibration- Withstands vibration between 0 and 55 Hz. on all axes. 10 years under normal operating conditions.
<b>Life Expectancy:</b>	For a period of two years from the date of manufacture under normal operating conditions.
<b>Warranty:</b>	

61663

OUTPUT SOUND and CURRENT CONSUMPTION vs. INPUT VOLTAGE PERFORMANCE.

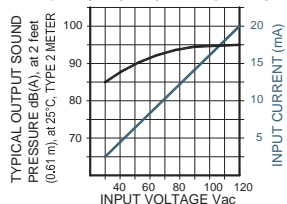

## DIMENSIONS

**REAR VIEW**  
STAINLESS STEEL SCREWS,  
6 X 32, 0.25" LONG.

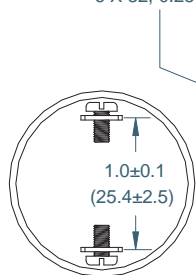

**SIDE VIEW**

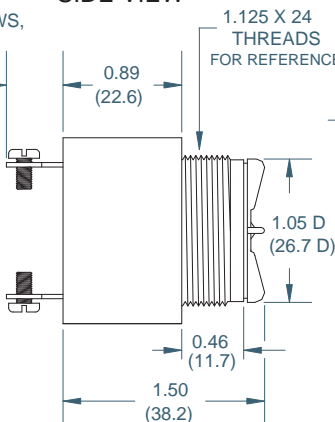

**RING**

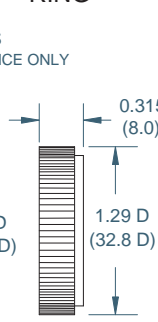

**FRONT VIEW**

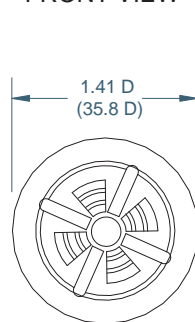

DIMENSIONS ARE IN: INCHES (mm)  
TOLERANCES ARE: ±0.03 (±0.76)  
UNLESS OTHERWISE SPECIFIED.

## PANEL MOUNTING

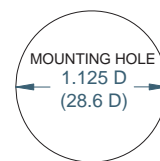

FITS PANELS UP-TO  
0.25 (6.3) THICK

"S" TERMINALS

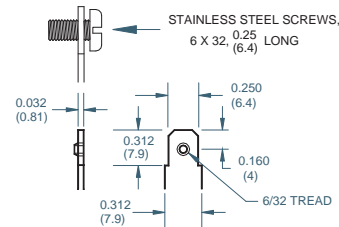

Floyd Bell Inc

An ISO 9001:2000 Registered Company

P.O. Box 12400 • 897 Higgs Avenue • Columbus, OH 43212-0400  
 Tel: 614/294-4000 • Fax: 614/291-0823  
 email: sales@floydbell.com • www.floydbell.com

Revision: 7.04



**Bulkhd:** Standard bulkhead connectors

**B-H/cable:** Standard bulkhead connector with cable.



**Extn:** Male-Female pin-pin extension cables.

**Term:** Printed circuit board pin-pin to terminal block OR Network Tap



Network Taps are designed for specific networks. Examples above: Modbus+, Data Highway+, DeviceNet, and more.

# Need Other Connector Codes?...CALL!

## GENERIC CONNECTOR CODES

### Universal Serial Bus

P11	USB Type A-A Cable	Extn	USB-AF	USB-AM
P22	USB Type A-A F/F	Bulkhd	USB-AF	USB-AF
Q50	USB Type A/B F/F	Bulkhd	USB-AF	USB-BF
Q51	USB Type B/A F/F	Bulkhd	USB-BF	USB-AF
P27	USB Type B/B F/F	Bulkhd	USB-BF	USB-BF
P31	USB Type B/B M/M	Bulkhd	USB-BM	USB-BM

### Ethernet & Network Interfaces

R2	Category 5e Ethernet	Bulkhd	RJ45F	RJ45F
R33	Category 5e Shielded	Bulkhd	RJ45F	RJ45F
R62	Category 6 Ethernet	Bulkhd	RJ45F	RJ45F

### BNC Connectors

Q79	75 Ohm BNC F/F-Auto-Terminating	Bulkhd	F	F
Q93	75 Ohm BNC F/F (RJ58)	Bulkhd	F	F
Q42	50 Ohm BNC F/F (RJ58)	Bulkhd	F	F

### Generic Bulkhead Interfaces

Q3	DB-9 F/F	Bulkhd	F	F
Q7	DB-9 F/M	Bulkhd	F	M
Q9	DB-9 M/F	Bulkhd	M	F
Q15	DB-9 M/M	Bulkhd	M	M
Q4	DB-25 F/F	Bulkhd	F	F
Q8	DB-25 F/M	Bulkhd	F	M
Q10	DB-25 M/F	Bulkhd	M	F
Q16	DB-25 M/M	Bulkhd	M	M
Q35	DB-15 F/F	Bulkhd	F	F
Q36	DB-15 M/M	Bulkhd	M	M
Q37	DB-15 F/M	Bulkhd	F	M
Q38	DB-15 M/F	Bulkhd	M	F
Q11	DB-15HD F/M	Bulkhd	F	M
Q12	DB-15HD M/F	Bulkhd	M	F
Q18	DB-15HD F/F	Bulkhd	F	F
Q19	DB-15HD M/M	Bulkhd	M	M
Q22	DB-15HDVGA F/F	Bulkhd	F	F
Q23	DB-15HDVGA M/F	Bulkhd	M	F
Q24	DB-15HDVGA F/M	Bulkhd	F	M
Q25	DB-15HDVGA M/M	Bulkhd	M	M
Q6	RJ-11/12 F/F	Bulkhd	F	F
Q17	RJ-45 F/F	Bulkhd	F	F
Q26	4 MDIN F/F	Bulkhd	F	F
Q28	6MDIN F/F	Bulkhd	F	F
Q29	8MDIN F/F	Bulkhd	F	F
Q26	S-Video F/F	Bulkhd	F	F
P24	S-Video F/M	Bulkhd	F	M
P25	S-Video M/F	Bulkhd	M	F
P26	S-Video M/M	Bulkhd	M	M

### Connector to Terminal Block PCB

R1	DB9F (PCB Pins 1-9 to TB)	Term	DB9F	TB
R12	DB9M (PCB Pins 1-9 to TB)	Term	DB9M	TB
R15	RJ-45 (PCB Pins 1-8 to TB)	Term	RJ45F	TB

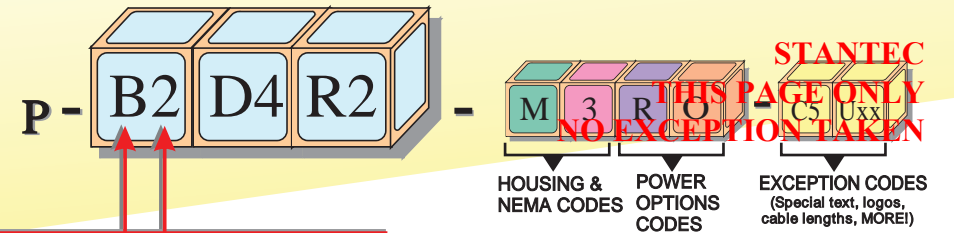

Alpha/Numeric Codes ordered Alphabetically and used in name of data sheet (i.e. D4.PDF)

## PLC CONNECTOR CODES

### Allen-Bradley (Rockwell Automation)

A5	PanelView (Serial)	Extn	DB9M	DB9F
A8	ControlLogix	Extn	DB9M	DB9F
A10	SCANport	Extn	8MDINF	8MDINM-lock
A11	PLC-5 Channel 0 (DB-25)	Extn	DB25F	DB25M
A12	SLC-500 Channel 0	Extn	DB9M	DB9F
A13	AIC+ Port 2	Extn	8 MDIN-F	8 MDIN-M
A14	MicroLogix (Series C)	Extn	8 MDIN-F	8 MDIN-M
A16	CompactLogix	Extn	DB9M	DB9F
A17	A-B FlexLogix	Extn	DB9M	DB9F
A18	MicroLogix 1500-LRP (DB-9)	Extn	DB9M	DB9F
A19	PowerFlex	Extn	8MDINF	8MDINM-lock
A20	PowerFlex 40,400	B/H-cable	RJ45F	RJ45M
B1	SLC 500 DH-485 (20' Cable)	Term	RJ45F	RJ45M
B14	A-B SLC 500 DH-485	Bulkhd	RJ45F	RJ45F

### Data Highway

B2	DH+ (DB9F PCB)	Term	DB9F	Terminal Block
B3	DH+ (8MDIN PCB)	Term	8MDINF	Terminal Block
B6	DH+ / Remote I/O	Term	3RTBM	Terminal Block
B9	DH+ Combo(DB9/8MDIN)	Term	8 MDIN/DB9F	Terminal Block

### ControlNet

B4	ControlNet RJ-45 (20' Cable)	Term	RJ45F	RJ45M
B7	ControlNet (75 Ohm BNC tap)	Term	BNCF	BNCF
B10	A-B ControlNet (20' cable)	B/H-Cable	RJ45F	RJ45M

## PLC NETWORK TAPS

### Network Taps

B2	A-B DH+ (DB9F PCB)	Term	DB9F	Terminal Block
B3	A-B DH+ (8MDIN PCB)	Term	8MDINF	Terminal Block
B6	A-B DH+ / Remote I/O	Term	3RTBM	Terminal Block
B9	A-B DH+ Combo (DB9/8MDIN)	Term	8 MDIN/DB9F	Terminal Block
D3	Profi-Bus (12MB max)	Term	DB9F	Terminal Block
D4	DeviceNet (8A Max)	Term	5RTBM	Terminal Block
M4	Modicon ModBus Plus Tap	Term	RJ-45	Terminal Block
M9	Schneider Automation -FIPWay	Term	DB9F	Terminal Block

CALL 800-880-9517 or 9517 for  
 Connector Codes (not shown)  
 Configuration Assistance

Connector Codes	Description	Type	Gender Outside	Gender Inside
XX	Null Connector code			

## Computer Interfaces

### Serial, Parallel

P1	DB9 Serial	Extn	DB9M	DB9F
P9	DB25 Serial	Extn	DB25M	DB25F
P2	DB25 Parallel	Extn	DB25F	DB25M

### Keyboard, Mouse, & Monitor

P3	Keyboard (PS/2)	Extn	6MDINF	6MDINM
P28	Keyboard (USB)	Extn	USBAF	USBAM
P5	Mouse (PS/2)	Extn	6MDINF	6MDINM
P29	USB Mouse	Extn	USBAF	USBAM
P6	VGA Monitor	Extn	HDDB15F	HDDB15M
Q102	DVI F/F (DVI-I, D, A)	Bulkhd	F	F
P7	Modem	Bulkhd	RJ12F	RJ12F

### Other Parallel Pin-to-Pin Extension Cables

R3	DB9 F/M	Extn	DB9F	DB9M
P1	DB9 M/F	Extn	DB9M	DB9F
P2	DB25 F/M	Extn	DB25F	DB25M
R9	DB25 M/F	Extn	DB25M	DB25F
R6	DB37 M/F	Extn	DB37M	DB37F
R7	DB37 F/M	Extn	DB37F	DB37M
R10	DB15 M/F	Extn	DB15M	DB15F
R11	DB15 F/M	Extn	DB15F	DB15M
R44	DB15HDM M/F (Not for VGA)	Extn	M	F
R45	DB15HDM F/M (Not for VGA)	Extn	F	M
R8	8 Pin MiniDIN	Extn	8MDINF	8MDINM
R28	8 Pin MiniDin Locking	Extn	8MDINF	8MDINM

### Data Switch Interfaces

R38	DB9F 2:1	Custom	F	F
R39	DB9F 4:1	Custom	F	F
R36	8MDin 2:1	Custom	F	F
R37	8MDin 4:1	Custom	F	F
R47	DB15 2:1	Custom	F	F
R48	DB15 4:1	Custom	F	F
R101	50 OHM BNC 2:1	Custom	F	F
R102	VGA 2:1	Custom	F	F
R103	RJ11/12 2:1	Custom	F	F
R104	RJ11/12 4:1	Custom	F	F



DS-Config 2006-07

©2006 Grace Engineered Products Inc. GracePort® and Inside-OUTlet® are registered trademarks of Grace Engineered Products Inc.

# GracePort® Interface Products Part Number Guide

## The Of Ordering

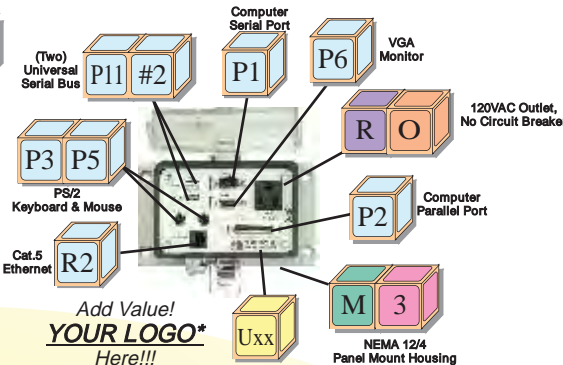
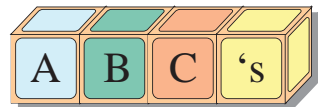

Add Value!  
YOUR LOGO\*  
Here!!!

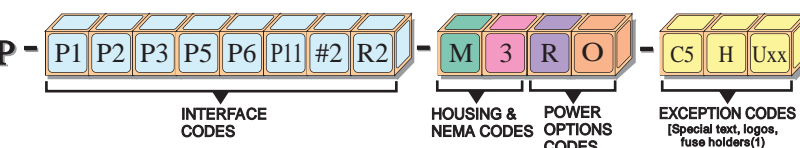

NEMA RATING CODES		NOTES
1	NEMA 1 (Panel mount no housing)	ADD "G" TO THE END OF THE PART NUMBER FOR GASKETING @
2	NEMA 4A	Type 4 @ (1)
3	NEMA 12/4 & IP-65	Type 4 @
4	NEMA 4X TYPE 304 STAINLESS STEEL	Type 4X @
6	NEMA 4X TYPE 316 STAINLESS STEEL	Type 4X @
7	NEMA 7&9 EXPLOSION PROOF	NO POWER OPTIONS @

### ThruView™ Housings

PANEL MOUNT HOUSING CODES	HOUSING SIZE	SURFACE MOUNT HOUSING CODES
B	6	A
F	16	E
H	24	G
K	32	N/A
M	48	L
M5	48	L5
M6	48	L6
N/A		M7

### NEW The Inside-Outlet®

POWER OPTION CODES	DESCRIPTION	VAC	AMPS
R	US, Canada, Mexico (also used in Japan & Taiwan)	120	15
RD	Duplex Outlet	120	20
RF	GFCI Inside-Outlet	120	20
RG	Isolated Ground (Duplex)	120	15
RM	IEC 320 Male Power Entry Module	250	10
RP	IEC 320 Female Power Entry Module	250	10

FOREIGN OUTLETS			
RA	Australia, New Zealand, & Peoples Republic of China	250	10
RB	United Kingdom, Hong Kong, Ireland, Singapore, & Malaysia	250	13
RE	Continental Europe "Schuko" (Germany, Finland, Netherlands, Norway, Sweden, Portugal, Spain, Greece, Soviet Republic, & Eastern Bloc)	250	16
RH	France & Belgian	250	16
RI	Italy	250	10
RU	India	250	15

Note: CALL for other power options not shown (other outlets, DC jacks, & customs)  
CE: EN61010/EN60950 (Foreign Power Outlets)

CIRCUIT BREAKER(1) CODES	
0	No Breaker
3	3 Amp 250V
5	5 Amp 250V
Call for other sizes	

(1) For higher interrupting short-circuit rating, Class CC fuse holders are available. Use code "H" in the exception codes field. Fuse not included. Call for more information.

GracePort® Part Guide

800-280-9517

www.grace-eng.com

## GracePort® Thru-Door Interfaces

- EVERY** Combination - 1000's & 1000's!!
- EVERY** Connector - USB, Serial, PS2, EtherNet, DeviceNet, DH/+...
- EVERY** Enclosure Type - Nema 12/4, 4X, 7/9, & Stainless Steel 4X
- VERY** Quick Delivery! - 2-3 Days Typical
- UL TYPE 4 & 4X(1)** Ratings - CSA & CE (Foreign Power Outlets)



SUBMITTAL Do Not Use For Installation

### PLC CONNECTOR CODES (cont)

Connector Codes	Description	Type	Gender Outside	Gender Inside
-----------------	-------------	------	----------------	---------------

Other PLC's				
G1	GE Fanuc Genius	Extn	DB9M	DB9F
G2	GE Fanuc (340 SNP, 9/30)	Extn	DB15F	DB15M
H5	Siemens Simatic 545-(1103,1104,1105,1106), 555-(1103,1104,1105,1106), 575-2104,2105,2106)	Extn	DB9F	DB9M
H6	Siemens Micro-Master	Extn	DB15F	DB15M
M5	Telemecanique UniTelway 8MDIN locking cable	Extn	8MDINF	8MDINM
M9	Schneider Automation -FIPWay	Term	DB9F	
M10	Mitsubishi FX Series PLC	Extn	8MDIN-F	8MDIN-M
M11	Mitsubishi A Series PLC	Extn	DB25F	DB25M
M13	Mitsubishi Q-Series PLC	Extn	6MDINF	6MDINM
M14	Omron Serial (DB9)	Extn	DB9M	DB9F
M15	Omron CS/CJ/CQ Peripheral Port (Use Omron Programming Cable)	Bulkhd	DB9F	DB9M

Modicon				
M4	ModBus Plus Industrial Tap	Term	RJ-45	Terminal Block
M6	ModBus Plus	Extn	DB9F	BLUNT
M7	Micro, E284-258/265/275/285	P/O	DB9F	RJ-45
M8	ModBus (Serial -Extension Cable Version)	Extn	DB9F	DB9M
M16	Momentum (Peripheral Port)	Extn	RJ-45F/F	RJ-45M
M17	Momentum	Extn	DB9F	RJ-45M

PLC Direct				
M20	(DL340/CPU Ports)	B/H Cable	RJ-11F/F	M
M21	(DL05,06,105,205,D3-350,D4-450 CPU Ports)	B/H Cable	RJ-12F/F	M
M22	(DL06, D2-250 Bottom Port)	Extn	DB15HD-F	M
M23	(DL405 Port CPU, DL405 SLICE I/O)	Extn	DB15-F	M
M24	(DL405 CPU/Bottom/DCM, DL305 w/DCU RS232)	Extn	DB25-F	M

Crossover Switch (See Data Sheets)				
R49	Crossover -Generic DB9F	Custom	Qty (2) DB9	
R53	MicroLogix 1000, 1200, 150LSP to PanelView 300 Micro	Custom	Qty (2) DB9	
R54	MicroLogix 1500 LRP, SLC,PLC5, Control Logix, Compact Logix, Flex Logix to PanelView 300 Micro	Custom	Qty (2) DB9	
R55	MicroLogix 1500 LRP, SLC,PLC5, Control Logix, Compact Logix, Flex Logix to PanelView(+) 300-1500	Custom	Qty (2) DB9	



www.graceport.com

5001 Tremont Ave  
Davenport, IA 52807  
FAX: 563-386-9639  
antiah@grace-eng.com

DS-Conflg 2006-07



**THIS PAGE ONLY  
 NO EXCEPTION TAKEN**

**CONTINUOUS HINGE WITH CLAMPS, TYPE 12**



**SPECIFICATIONS**

- Enclosure bodies are 14 or 16 gauge steel. Doors are 14 gauge steel.
- Seams continuously welded and ground smooth
- External wall-mounting brackets
- Formed external return flanges around all sides of enclosure opening
- Screw-down door clamps
- Removable heavy-gauge continuous hinge pin
- Hasp and staple for padlocking
- Data pocket is high-impact thermoplastic
- Collar studs provided for mounting optional panels
- Bonding provision on door

**FINISH**

White inside with ANSI 61 gray finish outside.

**ACCESSORIES**

See also *Accessories*.  
 Drip Shield Kit for Type 12 Enclosures  
 Electric Heater  
 Fast-Operating Clamp Assembly  
 Compact Cooling Fans  
 Steel and Stainless Steel Window Kits  
 See also the *Popular Cooling and Accessories tables following the Standard Product table*.

**MODIFICATION AND CUSTOMIZATION**

Hoffman excels at modifying and customizing products to your specifications. Contact your local Hoffman sales office or distributor for complete information.

**BULLETIN: A12**

**INDUSTRY STANDARDS**

UL 508A Listed; Type 12, 13; File No. E61997  
 cUL Listed per CSA C22.2 No. 94; Type 12, 13; File No. E61997

NEMA/EEMAC Type 12 and 13  
 CSA, File No. 42186: Type 12  
 IEC 60529, IP65

**APPLICATION**

For applications requiring a bright white interior to increase control visibility, this enclosure includes a padlocking hasp and staple for security and screw-down clamps for secure closure.

**Standard Product**

Catalog Number	AxBxC in./mm	Body Gauge	Panel	Conductive Panel	Panel Size D x E in./mm	F in./mm	Number of Clamps	Data Pocket
A122406LP	12.00 x 24.00 x 6.00 305 x 610 x 152	16	A12P24	A12P24G	9.00 x 21.00 229 x 533	3.00 76	2	Small
A161206LP	16.00 x 12.00 x 6.00 406 x 305 x 152	16	A16P12	A16P12G	13.00 x 9.00 330 x 229	1.25 32	2	Small
A161606LP	16.00 x 16.00 x 6.00 406 x 406 x 152	16	A16P16	A16P16G	13.00 x 13.00 330 x 330	3.00 76	2	Small
A162006LP	16.00 x 20.00 x 6.00 406 x 508 x 152	16	A20P16	A20P16G	17.00 x 13.00 432 x 330	3.00 76	2	Small
A201206LP	20.00 x 12.00 x 6.00 508 x 305 x 152	16	A20P12	A20P12G	17.00 x 9.00 432 x 229	1.25 32	2	Small
A201606LP	20.00 x 16.00 x 6.00 508 x 406 x 152	16	A20P16	A20P16G	17.00 x 13.00 432 x 330	3.00 76	2	Small
A202006LP	20.00 x 20.00 x 6.00 508 x 508 x 152	16	A20P20	A20P20G	17.00 x 17.00 432 x 432	3.00 76	2	Small
A202406LP	20.00 x 24.00 x 6.00 508 x 610 x 152	16	A24P20	A24P20G	21.00 x 17.00 533 x 432	3.00 76	2	Small
A241206LP	24.00 x 12.00 x 6.00 610 x 305 x 152	16	A12P24	A12P24G	9.00 x 21.00 229 x 533	1.25 32	2	Small
A241606LP	24.00 x 16.00 x 6.00 610 x 406 x 152	16	A24P16	A24P16G	21.00 x 13.00 533 x 330	3.00 76	2	Small
A242006LP	24.00 x 20.00 x 6.00 610 x 508 x 152	16	A24P20	A24P20G	21.00 x 17.00 533 x 432	3.00 76	2	Small
A242406LP	24.00 x 24.00 x 6.00 610 x 610 x 152	16	A24P24	A24P24G	21.00 x 21.00 533 x 533	3.00 76	2	Small
A301606LP	30.00 x 16.00 x 6.00 762 x 406 x 152	14	A30P16	A30P16G	27.00 x 13.00 686 x 330	3.00 76	2	Small
A302006LP	30.00 x 20.00 x 6.00 762 x 508 x 152	14	A30P20	A30P20G	27.00 x 17.00 686 x 432	3.00 76	2	Small
A302406LP	30.00 x 24.00 x 6.00 762 x 610 x 152	14	A30P24	A30P24G	27.00 x 21.00 686 x 533	3.00 76	2	Large
A362406LP	36.00 x 24.00 x 6.00 914 x 610 x 152	14	A36P24	A36P24G	33.00 x 21.00 838 x 533	3.00 76	2	Large
A363006LP	36.00 x 30.00 x 6.00 914 x 762 x 152	14	A36P30	A36P30G	33.00 x 27.00 838 x 686	3.00 76	2	Large
A122408LP	12.00 x 24.00 x 8.00 305 x 610 x 203	16	A12P24	A12P24G	9.00 x 21.00 229 x 533	3.00 76	2	Small
A161208LP	16.00 x 12.00 x 8.00 406 x 305 x 203	16	A16P12	A16P12G	13.00 x 9.00 330 x 229	1.25 32	2	Small
A161608LP	16.00 x 16.00 x 8.00 406 x 406 x 203	16	A16P16	A16P16G	13.00 x 13.00 330 x 330	3.00 76	2	Small

**THIS PAGE ONLY  
 NO EXCEPTION TAKEN**

Catalog Number	AxBxC in./mm	Body Gauge	Panel	Conductive Panel	Panel Size D x E in./mm	F in./mm	Number of Clamps	Data Pocket
A201612LP	20.00 x 16.00 x 12.00 508 x 406 x 305	14	A20P16	A20P16G	17.00 x 13.00 432 x 330	3.00 76	2	Small
A242012LP	24.00 x 20.00 x 12.00 610 x 508 x 305	14	A24P20	A24P20G	21.00 x 17.00 533 x 432	3.00 76	2	Small
A242412LP	24.00 x 24.00 x 12.00 610 x 610 x 305	14	A24P24	A24P24G	21.00 x 21.00 533 x 533	3.00 76	2	Small
A302412LP	30.00 x 24.00 x 12.00 762 x 610 x 305	14	A30P24	A30P24G	27.00 x 21.00 686 x 533	3.00 76	2	Large
A303012LP	30.00 x 30.00 x 12.00 762 x 762 x 305	14	A30P30	A30P30G	27.00 x 27.00 686 x 686	3.00 76	2	Large
A362412LP	36.00 x 24.00 x 12.00 914 x 610 x 305	14	A36P24	A36P24G	33.00 x 21.00 838 x 533	3.00 76	2	Large
A363012LP	36.00 x 30.00 x 12.00 914 x 762 x 305	14	A36P30	A36P30G	33.00 x 27.00 838 x 686	3.00 76	2	Large
A363012LP	36.00 x 30.00 x 12.00 914 x 914 x 305	14	A36P30	A36P30G	33.00 x 33.00 838 x 838	3.00 76	2	Large
A423012LP	42.00 x 30.00 x 12.00 1067 x 762 x 305	14	A42P30	A42P30G	39.00 x 27.00 991 x 686	3.00 76	2	Small
A423612LP	42.00 x 36.00 x 12.00 1067 x 914 x 305	14	A42P36	A42P36G	39.00 x 33.00 991 x 838	3.00 76	2	Large
A483612LP	48.00 x 36.00 x 12.00 1219 x 914 x 305	14	A48P36	A48P36G	45.00 x 33.00 1143 x 838	3.00 76	3	Large
A603612LP	60.00 x 36.00 x 12.00 1524 x 914 x 305	14	A60P36	A60P36G	57.00 x 33.00 1448 x 838	3.00 76	3	Large
A723612LP	72.00 x 36.00 x 12.00 1829 x 914 x 305	14	A72P36	A72P36G	69.00 x 33.00 1753 x 838	3.00 76	3	Large
A242016LP	24.00 x 20.00 x 16.00 610 x 508 x 406	14	A24P20	A24P20G	21.00 x 17.00 533 x 432	3.00 76	2	Small
A242416LP	24.00 x 24.00 x 16.00 610 x 610 x 406	14	A24P24	A24P24G	21.00 x 21.00 533 x 533	3.00 76	2	Small
A302416LP	30.00 x 24.00 x 16.00 762 x 610 x 406	14	A30P24	A30P24G	27.00 x 21.00 686 x 533	3.00 76	2	Large
A363016LP	36.00 x 30.00 x 16.00 914 x 762 x 406	14	A36P30	A36P30G	33.00 x 27.00 838 x 686	3.00 76	2	Large
A423616LP	42.00 x 36.00 x 16.00 1067 x 914 x 406	14	A42P36	A42P36G	39.00 x 33.00 991 x 838	3.00 76	2	Large
A483616LP	48.00 x 36.00 x 16.00 1219 x 914 x 406	14	A48P36	A48P36G	45.00 x 33.00 1143 x 838	3.00 76	3	Large
A603616LP	60.00 x 36.00 x 16.00 1524 x 914 x 406	14	A60P36	A60P36G	57.00 x 33.00 1448 x 838	3.00 76	3	Large
A302420LP	30.00 x 24.00 x 20.00 762 x 610 x 508	14	A30P24	A30P24G	27.00 x 21.00 686 x 533	3.00 76	2	Large
A363020LP	36.00 x 30.00 x 20.00 914 x 762 x 508	14	A36P30	A36P30G	33.00 x 27.00 838 x 686	3.00 76	2	Large
A483620LP	48.00 x 36.00 x 20.00 1219 x 914 x 508	14	A48P36	A48P36G	45.00 x 33.00 1143 x 838	3.00 76	3	Large
A603620LP	60.00 x 36.00 x 20.00 1524 x 914 x 508	14	A60P36	A60P36G	57.00 x 33.00 1448 x 838	3.00 76	3	Large
A302424LP	30.00 x 24.00 x 24.00 762 x 610 x 610	14	A30P24	A30P24G	27.00 x 21.00 686 x 533	3.00 76	2	Large

Purchase panels separately. Optional stainless steel, conductive, composite and aluminum panels are available for most sizes.

Small Data Pocket is 6.00 in. x 6.00 in. Large Data Pocket is 12.00 in. x 12.00 in.

**THIS PAGE ONLY  
NO EXCEPTION TAKEN**

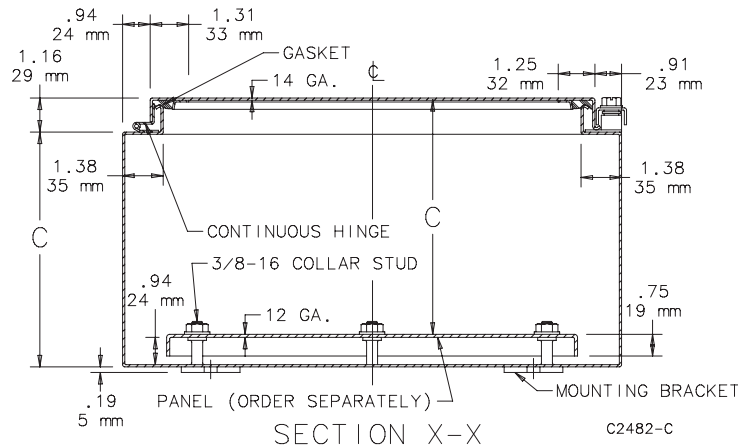
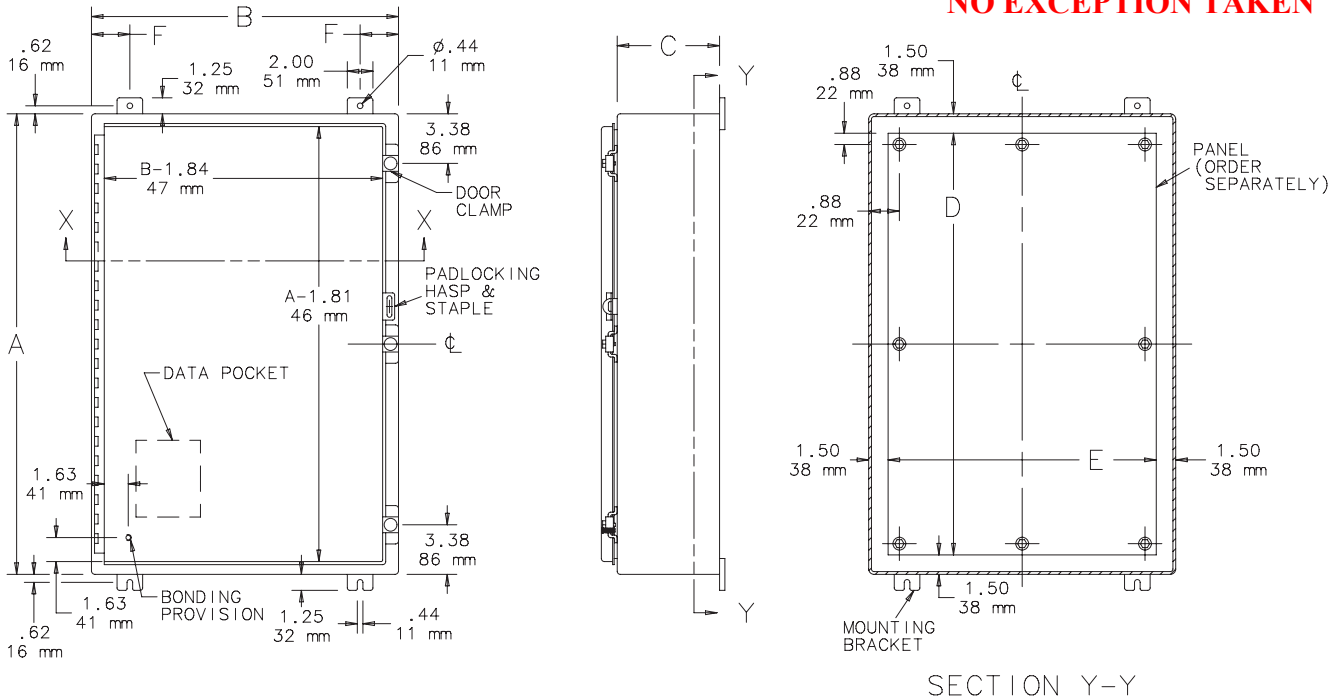

Popular Cooling Products

Enclosure Depth (C Dimension)	Thermoelectric Cooler*
6 in. (152 mm)	SF0416414
8 in. (203 mm)	SF0516414
10 in. (254 mm)	SF0916414
12 in. (305 mm)	SF1016414
16 in. (406 mm)	SF1316414
20 in. (508 mm)	SF1316414
24 in. (610 mm)	SF1316414

\*Important: Visit [tools.hoffmanonline.com/attachments](http://tools.hoffmanonline.com/attachments) to access our **Cooling Selection Tool** to determine the appropriate cooling solution for your application.

Popular Accessories

Enclosure Width (B Dimension)	Light	Hole Seals	Window Kits
12 in. (305 mm)	LEDPUCK	AS050	APWK53NF
16 in. (406 mm)	LEDA2M35	AS050	APWK53NF
20 in. (508 mm)	LED24V15	AS050	APWK53NF
24 in. (610 mm)	LED24V15	AS050	APWK53NF
30 in. (762 mm)	LED24V15	AS050	APWK53NF
36 in. (914 mm)	LED24V15	AS050	APWK53NF

# KBMG SERIES

## ULTRACOMPACT REGENERATIVE DRIVE

FULL-WAVE • 4-QUADRANT • IP-20

SCR Bidirectional Variable Speed and Torque Control  
for PM and DC Shunt Motors

Models KBMG-21D, 212D cover:

1/50 – 1 HP<sup>1</sup> @ 115 VAC – 50/60 Hz

1/25 – 2 HP<sup>1</sup> @ 230 VAC – 50/60 Hz

- Conveyors • Indexers • Feeders • Positioners
- Textile Equipment • Packaging Machinery
- Web Control • Converting Machinery



**THIS PAGE ONLY  
NO EXCEPTION TAKEN**

### STANDARD FEATURES

#### • Jumper Selectable Features

- Operation Mode: Speed, Torque
- AC Line Voltage (VAC – 50/60 Hz): 115, 230
- DC Armature Voltage (VDC): 90, 180
- Tach-generator Voltage (VDC/1000 RPM): 7, 50
- DC Current Output Ranges (ADC): (0.17 – 1.0, 1.7 – 10<sup>1</sup>)
- Analog Input Voltage (VDC): 0 to ±10, 0 to ±15
- Enable: Coast to Stop (CTS), Regenerate to Stop (RTS)

#### • Trimpot Adjustments

- Dead Band (DB) • Response (RESP) • IR Compensation (IR)
- Forward Current Limit (FCL) • Reverse Current Limit (RCL)
- Maximum Speed (MAX) • Forward Acceleration (FACC)
- Reverse Acceleration (RACC)

#### • LEDs

- Power On (PWR ON) • Overload (OL)

### SPECIFICATIONS

AC Line Input Voltage (VAC ±10%, 50/60 Hz)	115 or 230
AC Line Frequency (Hz)	50/60
Armature Voltage Range 115 VAC Line (VDC)	0 to ± 90
Armature Voltage Range 230 VAC Line (VDC)	0 to ± 90, 0 to ± 180
Field Voltage at 115 VAC Line (VDC)	100 / 50
Field Voltage at 230 VAC Line (VDC)	200 / 100
Maximum Load Capacity (% for 2 Minutes)	150
Ambient Temperature Operating Range (°C)	0 to 50
Speed Range (Ratio)	50:1
Armature Feedback Load Regulation (% Base Speed)	±1 <sup>3</sup>
Tach-generator Feedback Load Regulation (% Set Speed)	±1 <sup>3</sup>
AC Line Regulation (% Base Speed)	±0.5 <sup>3</sup>
KBMG-21D Current Ranges (Amps DC)	0.17, 0.25, 0.5, 0.75, 1.0
KBMG-212D Current Ranges (Amps DC)	1.7, 2.5, 5.0, 7.5, 10 <sup>1</sup>
Forward Accel (FACC) and Reverse Accel (RACC) Range (Sec.)	0.1 to 15
Dead Band Range (% Base Speed)	0 to ±5
Max Speed Trimpot Range (% Base Speed)	55 to 110 <sup>3</sup>
IR Comp Range at 115 VAC Line (VDC @ Full Load)	0 to 20
IR Comp Range at 230 VAC Line (VDC @ Full Load)	0 to 40
Forward CL (FCL) and Reverse CL (RCL) Range (% Range Setting)	0 to 175
Voltage Following Input Range (VDC) <sup>4</sup>	0 to ±10, 0 to ±15
Voltage Following Linearity (% Base Speed)	±0.5

**Notes:**

1. Maximum rating indicated is with Auxiliary Heat Sink (Part No. 9861). For maximum rating without Auxiliary Heat Sink see Electrical Rating Chart. 2. CE compliance requires KBRF-200A RFI Filter (or equivalent) and proper wiring practices. 3. Performance is for 90V PM motors on 115 VAC and 180V PM motors on 230 VAC. 4. Requires isolated input or SIMG Signal Isolator (Part No. 8832).

### DESCRIPTION

The KBMG are ultracompact, full-wave regenerative drives capable of operating DC PM or Shunt motors in a bidirectional mode. Its (4) quadrant operation provides forward and reverse torque in both speed directions. This allows the control to maintain constant speed with overhauling loads and provides rapid reversing and controlled braking. Because of its excellent controllability and response time, the KBMG can replace servos in many applications. The control is factory set for armature feedback, which provides up to 1% load regulation over a motor base speed of 50:1. Tach-generator feedback is also provided for superior load regulation if required. A simple jumper setting converts the KBMG to a torque control. In this mode, motor torque rather than motor speed is controlled.

An important feature of the drive is the factory-calibrated, built-in, selectable motor current jumper. It eliminates the need to recalibrate IR Comp and Current Limit for most applications.

The control contains an Enable function that can be used to start and stop the motor electronically via a contact closure. Through a jumper selection, the motor can be controlled to rapidly “regenerate to stop” or to “coast to stop.”

KB's exclusive Auto Inhibit® circuit provides safe, smooth starting even during rapid cycling of the AC line. The Overspeed Protect Circuit prevents failure of the power bridge in extreme overhauling conditions. Reliability of the KBMG is further enhanced with the use of a high speed current limit circuit and MOV transient protection. LED's, which can be used for diagnostics, are provided for power on and motor overload. A rugged extruded aluminum heat sink ensures enhanced heat transfer, which provides a higher control rating while maintaining cooler running SCR's. The KBMG contains a finger-safe cover to meet the IP-20 Standard.

Power connections to the KBMG are made via quick connect terminals and signal input connections are made via a removable barrier terminal block. A 5k remote potentiometer and full operating instructions are supplied.

### ACCESSORIES

- **Auxiliary Heat Sink (Part No. 9861)** – Increases the control rating to 1 HP at 90 VDC and 2 HP at 180 VDC. Dimensions (L x W x H approx.): 7.0" x 6.3" x 1.9".
- **SIMG Bipolar Signal Isolator (Part No. 8832)** – Allows a non-isolated signal source to be used.
- **Multi Speed Board (Part No. 8833)** – Provides discrete preset speeds which can be controlled from a PLC.
- **DIN Rail Mounting Kit (Part No. 9995)** – Converts control to standard DIN Rail Mounting.

## ELECTRICAL RATINGS

**THIS PAGE ONLY  
 NO EXCEPTION TAKEN**

Model	Part No.	AC Line Voltage (VAC) ±10% 50/60 Hz	Motor Voltage (VDC)	Maximum Rating Without Auxiliary Heat Sink			Maximum Rating With Auxiliary Heat Sink		
				AC Line Current (RMS Amps)	DC Load Current (Avg. Amps)	Horsepower HP, (kW)	AC Line Current (RMS Amps)	DC Load Current (Avg. Amps)	Horsepower HP, (kW)
KBMG-21D	8830	115	0 - ±90	1.5	1.0	.075, (.06)	—	—	—
		208/230	0 - ±180	1.5	1.0	.15, (.11)	—	—	—
KBMG-212D	8831	115	0 - ±90	12.0	8.0	.75, (.6)	16.0	11.0	1.0, (.75)
		208/230	0 - ±180	12.0	8.0	1.5, (1.1)	16.0	11.0	2.0, (1.50)

## CONNECTION DIAGRAMS

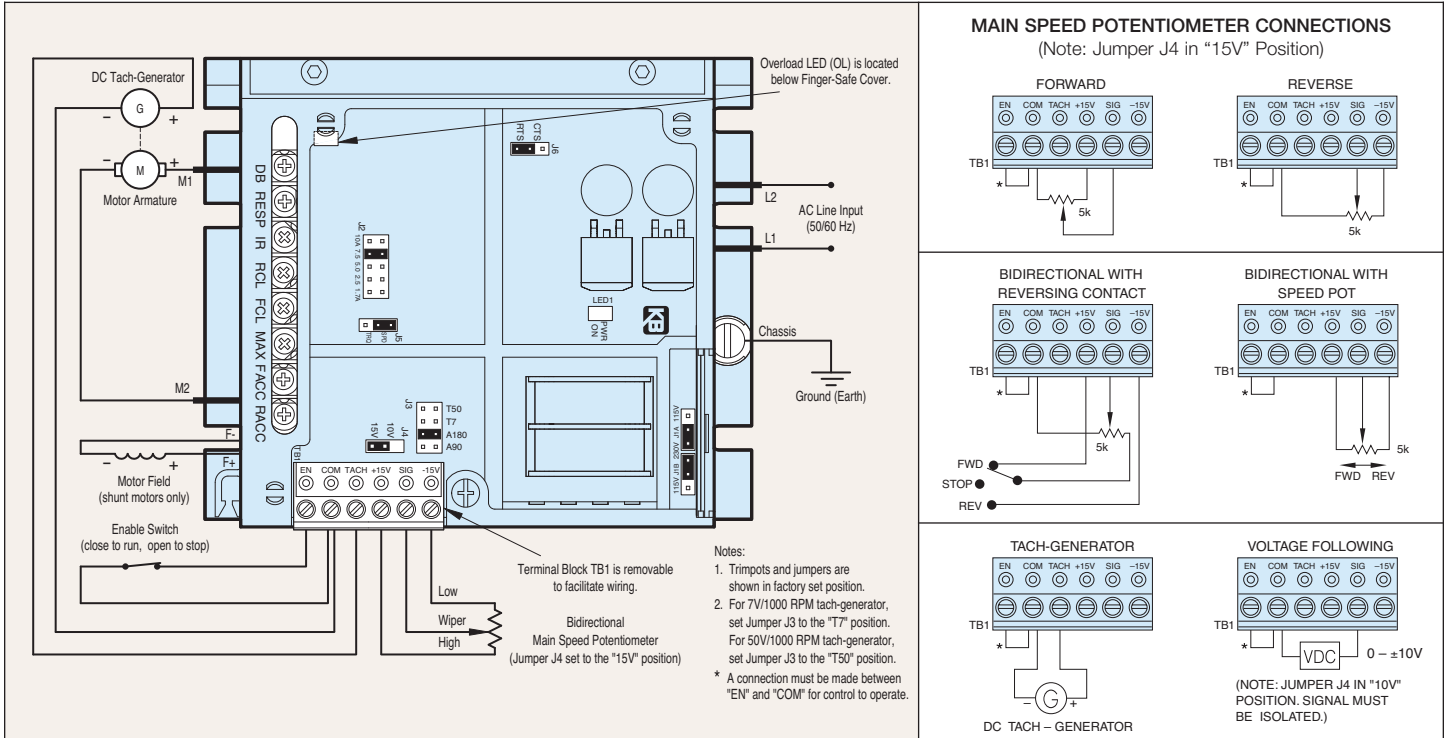

## MECHANICAL SPECIFICATIONS (Inches / mm)

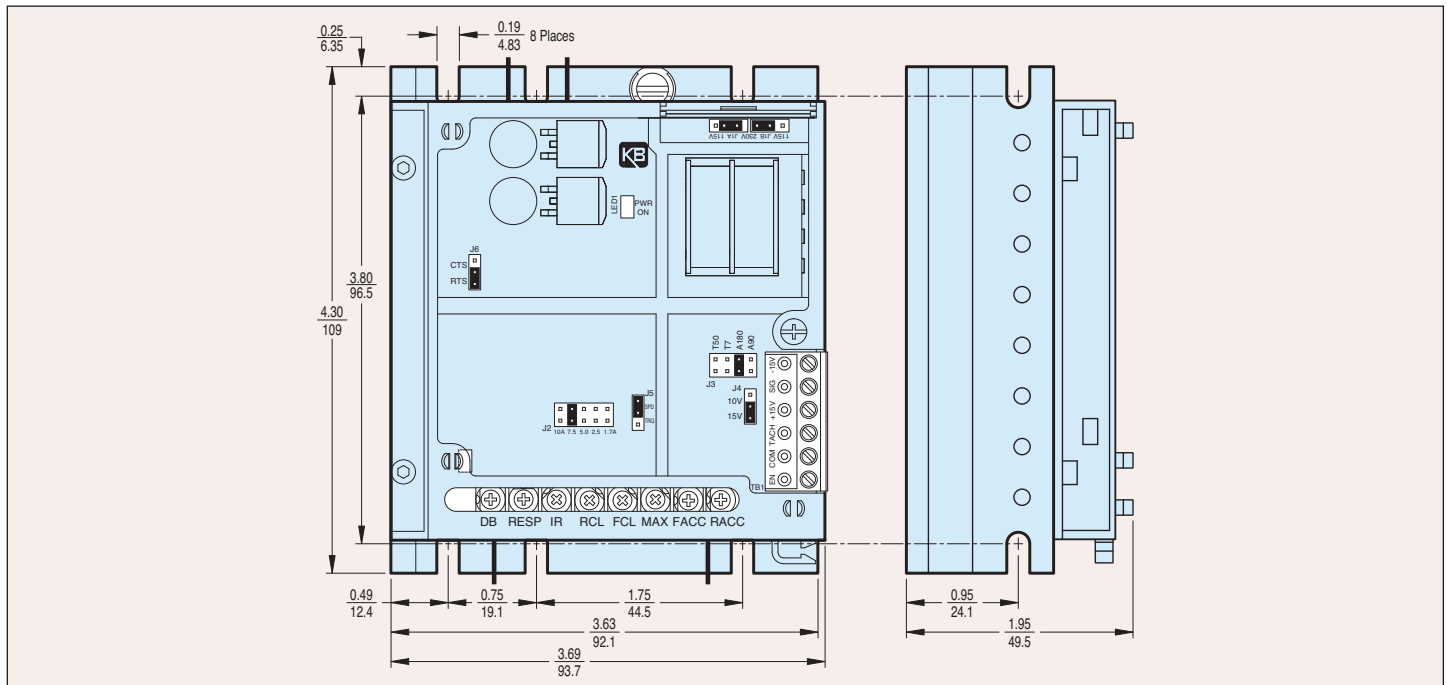

**NO EXCEPTION TAKEN**

RoHS  **235 Series, 5 x 20 mm, Fast-Acting Fuse**



**Description**

5x20mm fast-acting glass body cartridge fuse designed to UL specification.





**Features**

- Designed to UL/CSA/ ANCE 248 Standard
- Available in cartridge and axial lead format
- RoHS compliant and lead-free

**Applications**

Used as supplementary protection in appliance or utilization equipment to provide individual protection for components or internal circuits.

**Agency Approvals**

Agency	Agency File Number	Ampere Range
	Cartridge Certificates: NBK290502-E10480 G NBK290502-E10480 I Leaded Certificates: NBK290502-E10480 H NBK290502-E10480 J	1A – 5A 6A & 7A
	Certificates: SU05001 – 3007 SU05001 – 2002 SU05001 – 2003	100mA – 400mA 500mA – 3A 4A – 6A
	Listed File: E10480 Guide No: JDYX	100mA - 7A
	File No: 029862 Certificate Class No: LR1422-01	100mA – 3A 4A – 6A
		100mA – 7A

**Electrical Characteristics for Series**

% of Ampere Rating	Ampere Rating	Opening Time
100%	100mA – 7A	4 hours, Minimum
135%		1 hour, Maximum
200%		5 seconds, Maximum

**235 Series**

NO EXCEPTION TAKEN

### Electrical Characteristic Specifications by Item

Amp Code	Amp Rating (A)	Voltage Rating (V)	Interrupting Rating	Nominal Cold Resistance (Ohms)	Nominal Melting I <sup>2</sup> t (A <sup>2</sup> sec)	Agency Approvals				
						CE	UL	SF	PS E	RoHS
.100	0.1	250	35A@250Vac, 10000A@125Vac	8.4000	0.00312	x	x	x		x
.125	0.125	250		5.7500	0.00273	x	x	x		x
.200	0.2	250		3.1500	0.00867	x	x	x		x
.250	0.25	250		2.2500	0.01660	x	x	x		x
.300	0.3	250		1.6000	0.03215	x	x	x		x
.400	0.4	250		1.750	0.05845	x	x	x		x
.500	0.5	250		0.4265	0.06915	x	x	x		x
.600	0.6	250		0.3195	0.11200	x	x	x		x
.700	0.7	250		0.2625	0.15600	x	x	x		x
.800	0.8	250		0.1920	0.25300	x	x	x		x
001.	1	250	100A@250Vac, 10000A@125Vac	0.1530	0.46750	x	x	x	x	x
1.25	1.25	250		0.1055	1.08500	x	x	x	x	x
01.6	1.6	250		0.0758	2.02500	x	x	x	x	x
002.	2	250		0.0603	2.64500	x	x	x	x	x
02.5	2.5	250		0.0437	5.44500	x	x	x	x	x
003.	3	250		0.0347	8.39500	x	x	x	x	x
03.5	3.5	250	0.0331	17.14000	x	x		x		
004.	4	125	10000@125Vac	0.0246	17.14000	x	x	x	x	x
005.	5	125		0.0184	27.41000	x	x	x	x	x
006.	6	125		0.0148	47.32500	x	x	x	x	x
007.	7	125		0.0157	64.81500	x	x		x	

### Temperature Derating Curve

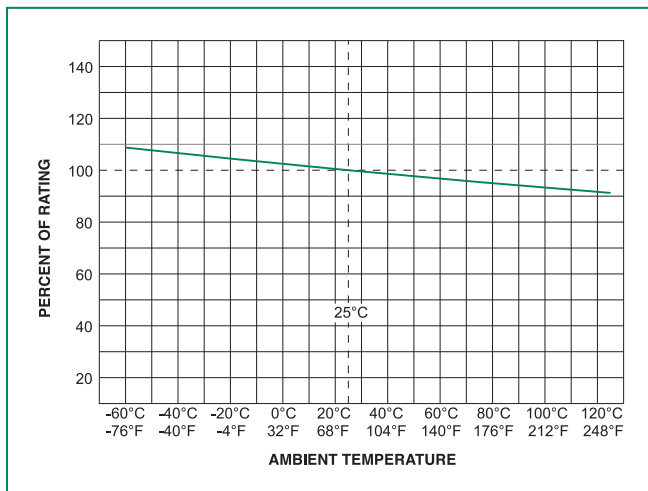

### Average Time Current Curves

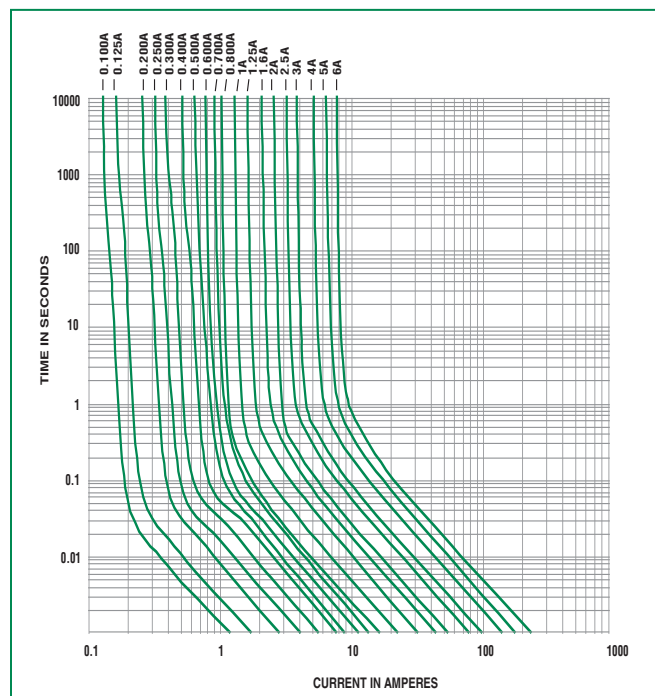

Please contact Littelfuse for details on FC curve for 7A rating

### Soldering Parameters - Wave Soldering

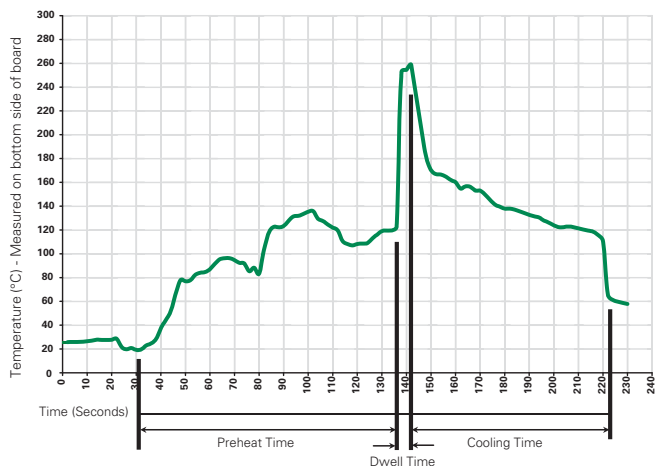

#### Recommended Process Parameters:

Wave Parameter	Lead-Free Recommendation
<b>Preheat:</b> (Depends on Flux Activation Temperature) (Typical Industry Recommendation)	
Temperature Minimum:	100° C
Temperature Maximum:	150° C
Preheat Time:	60-180 seconds
<b>Solder Pot Temperature:</b>	260° C Maximum
<b>Solder Dwell Time:</b>	2-5 seconds

#### Recommended Hand-Solder Parameters:

Solder Iron Temperature: 350° C +/- 5°C  
 Heating Time: 5 seconds max.

**Note: These devices are not recommended for IR or Convection Reflow process.**

### Product Characteristics

<b>Materials</b>	Body: Glass Cap: Nickel-plated brass Leads: Tin-plated Copper
<b>Terminal Strength</b>	MIL-STD-202G, Method 211A. Test Condition A
<b>Solderability</b>	Reference IEC 60127 Second Edition 2003-01 Annex A
<b>Product Marking</b>	Cap 1: Brand logo, current and voltage rating Cap 2: Series and agency approval markings
<b>Packaging</b>	Available in Bulk (M=1000 pcs/pkg) or on Tape/Reel (MRET1=1000 pcs/reel)

<b>Operating Temperature</b>	-55°C to +125°C
<b>Thermal Shock</b>	MIL-STD-202G, Method 107G, Test Condition B: (5 cycles -65°C + 125°C)
<b>Vibration</b>	MIL-STD-202G, Method 201A
<b>Humidity</b>	MIL-STD-202G, Method 103B, Test Condition A high RH (95%) and elevated temperature (40° C) for 240 hours
<b>Salt Spray</b>	MIL-STD-202G, Method 101D, Test Condition B

NO EXCEPTION TAKEN

### Dimensions

**0235000P**

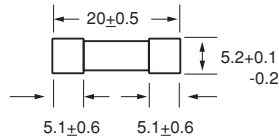

**0235.100 XEP  
 to  
 0235.400 XEP**

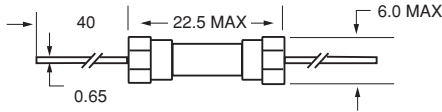

**0235.500 XEP  
 to  
 0235006.XEP**

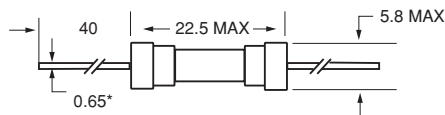

All dimensions in mm

Notes:

\* Ratings above 6.3A  
 ø0.8 mm dia lead

### Part Numbering System

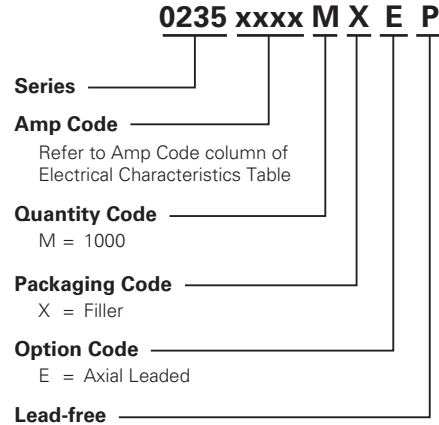

### Packaging

Packaging Option	Packaging Specification	Quantity	Quantity & Packaging Code	Taping Width
<b>235 Series</b>				
Bulk	N/A	1000	MX	N/A
Bulk	N/A	1000	MXB	N/A
Reel and Tape	EIA 296-E	1000	MRET1	T1=52mm (2.062")

325/326 Series Lead-Free 3AB, Slo-Blo® Fuse



**Description**

The 3AB Slo-Blo® Fuse with ceramic body construction permits higher interrupting ratings and voltage ratings. Ideal for applications where high current loads are expected.

**Features**

- In accordance with UL Standard 248-14
- Available in cartridge and axial lead format and with various forming dimensions
- RoHS compliant and Lead-free

**Applications**

Used as supplementary protection in appliance or utilization equipment to provide individual protection for components or internal circuits.

**Agency Approvals**

Agency	Agency File Number	Ampere Range
	E10480	0.250A - 10A
	E10480	12A - 30A
	29862	0.250A - 30A
	Cartridge: NBK 030805-E10480A NBK 030805-E10480C NBK 030805-E10480E NBK 260106-JP1021A Leaded: NBK 030805-E10480B NBK 030805-E10480D NBK 030805-E10480F NBK 260106-JP1021B	1A-3.2A 4A-5A 6.25A-15A 20A-30A 1A-3.2A 4A-5A 6.25A-15A 20A-30A
	SU05001-5010 SU05001-5011 SU05001-5012 SU05001-6006 SU05001-6007	7-10A 12A, 15A 20A 2.8A-3.2A 2.5A
	T 50239752 01	*12A/*15A/*20A
	N/A	0.010A - 30A

\* Approved for cartridge version only

**Electrical Characteristics for Series**

% of Ampere Rating	Ampere Rating	Opening Time
100%	0.010A – 30A	4 hours, Minimum
135%	0.010A – 30A	1 hour, Maximum
200%	0.010A – 3.2A	5 sec., Min., 30 sec., Max.
	4A – 30A	5 sec., Min., 60 sec., Max.

**Additional Information**

 <b>Datasheet</b> 325 Series	 <b>Resources</b> 325 Series	 <b>Samples</b> 325 Series	 <b>Accessories</b> 325 Series
 <b>Datasheet</b> 326 Series	 <b>Resources</b> 326 Series	 <b>Samples</b> 326 Series	 <b>Accessories</b> 326 Series

For recommended fuse accessories for this product series, see '[Recommended Accessories](#)' section.

# Axial Lead & Cartridge Fuses

3AB > Slo-Blo® Fuse > 325/326 Series

**NO EXCEPTION TAKEN**

## Electrical Characteristic Specifications by Item

Amp Code	Ampere Rating (A)	Voltage Rating (V)	Interrupting Rating	Nominal Cold Resistance (Ohms)	Nominal Melting I <sup>2</sup> t (A <sup>2</sup> sec)	Agency Approvals						
						PS E	RU	SP	UL	CE	△	Ⓜ
.010	0.01	250	100A@250Vac	3324.8000	0.00013					x		
.031	0.031	250		332.5000	0.0110					x		
.062	0.062	250		91.7000	0.0276					x		
.100	0.1	250		33.5500	0.0870					x		
.125	0.125	250		22.4500	0.100					x		
.150	0.15	250		15.4500	0.143					x		
.175	0.175	250		8.9200	0.350					x		
.187	0.187	250		7.7250	0.330					x		
.200	0.2	250		6.7700	0.316					x		
.250	0.25	250		4.4300	0.804			x	x	x		
.300	0.3	250	3.2200	1.230			x	x	x			
.375	0.375	250	2.1550	1.20			x	x	x			
.400	0.4	250	1.9350	1.33			x	x	x			
.500	0.5	250	1.3000	4.80			x	x	x			
.600	0.6	250	0.9495	3.90			x	x	x			
.700	0.7	250	0.7215	6.42			x	x	x			
.750	0.75	250	0.6410	13.00			x	x	x			
.800	0.8	250	0.5725	8.20			x	x	x			
001.	1	250	0.3890	16.3	x		x	x	x			
01.2	1.2	250	0.2860	22.0	x		x	x	x			
1.25	1.25	250	0.2680	40.0	x		x	x	x			
01.5	1.5	250	0.1975	59.7	x		x	x	x			
01.6	1.6	250	0.1760	66.0	x		x	x	x			
002.	2	250	0.1210	118.0	x		x	x	x			
02.5	2.5	250	0.0835	185.0	x		x	x	x		x	
02.8	2.8	250	0.0695	232.0	x		x	x	x		x	
003.	3	250	0.0605	200.0	x		x	x	x		x	
03.2	3.2	250	100A@250Vac 10KA@125Vdc	0.0539	214.0	x		x	x	x	x	
004.	4	250	400A@250Vac 10KA@125Vdc 10KA@125Vdc	0.0761	9.71	x		x	x	x		
005.	5	250		0.0522	25.0	x		x	x	x		
6.25	6.25	250		0.0346	60.4	x		x	x	x		
007.	7	250		0.0227	47.3	x		x	x	x	x	
008.	8	250		0.0193	67.1	x		x	x	x	x	
010.	10	250	0.0132	137	x		x	x	x	x		
012.	12	250	400A@250Vac 10KA@125Vdc 600A@125Vdc	0.0067	129	x	x	x		x	x***	
012.*	12	250	1500A@250Vac	0.0011	618		x	x		x		
015.	15	250	400A@250Vac 10KA@125Vdc 600A@125Vdc	0.0050	245	x	x	x		x	x***	
015.*	15	250	1500A@250Vac	0.0083	760		x	x		x		
020.	20	250	400A@250Vac 10KA@125Vdc 600A@125Vdc	0.0034	575	x	x	x		x	x***	
020.*	20	250	1500A@250Vac	0.0042	2500		x	x		x		
025.**	25	250	1500A@250Vac	0.0032	4682		x			x		
025.	25	250	400A@250Vac 10KA@60Vdc	0.0024	1030	x	x	x		x		
030.	30	250	600A@125Vdc	0.0019	1690	x	x	x		x		

\*Higher I<sup>2</sup>t version available. Please add suffix "D" to part numbers. For instance, 0325020.MXDP, 0326020.MXDP  
 I<sup>2</sup>t test at 10x rated current.

\*\*Higher I<sup>2</sup>t version available. Please add suffix "W" to part numbers. For instance, 0325025.MXWP

\*\*\*Approved for cartridge versions only, and interrupting rating is 400A@125Vdc and 400A@250Vac

© 2016 Littelfuse, Inc.

Specifications are subject to change without notice.

Revised: 12/16/16

**Temperature Re-rating Curve**

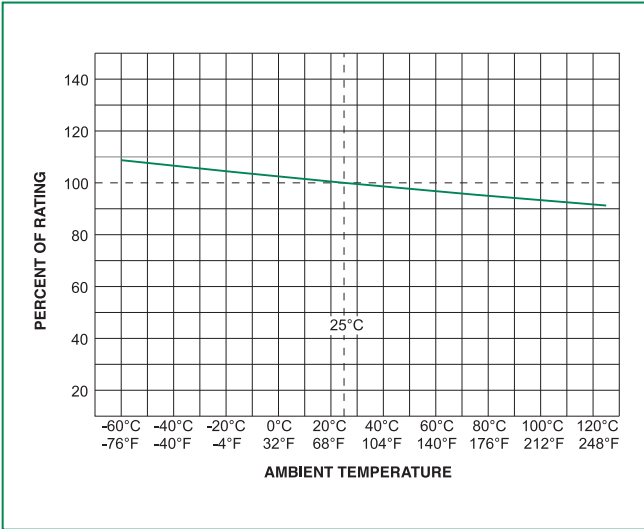

Note:  
Rerating depicted in this curve is in addition to the standard derating of 25% for continuous operation.

**Average Time Current Curves**

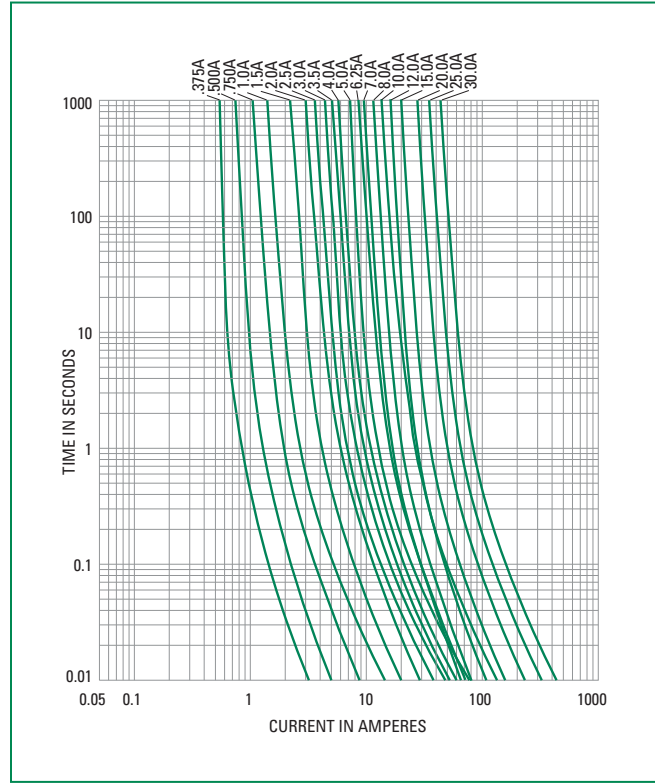

**Soldering Parameters - Wave Soldering**

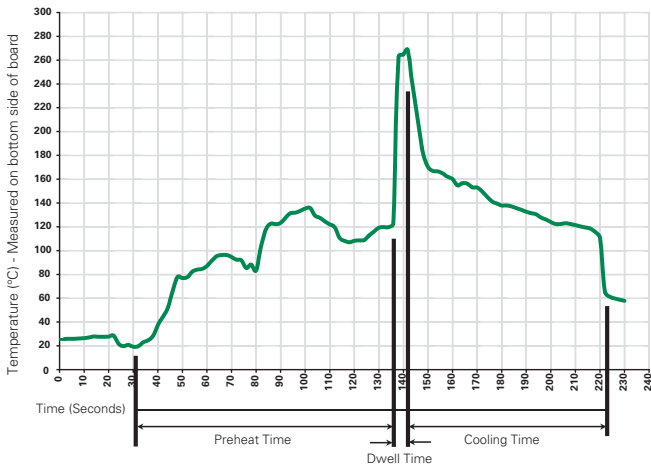

**Recommended Process Parameters:**

Wave Parameter	Lead-Free Recommendation
<b>Preheat:</b> (Depends on Flux Activation Temperature) (Typical Industry Recommendation)	
Temperature Minimum:	100°C
Temperature Maximum:	150°C
Preheat Time:	60-180 seconds
<b>Solder Pot Temperature:</b>	260°C Maximum
<b>Solder Dwell Time:</b>	2-5 seconds

**Recommended Hand-Solder Parameters:**

Solder Iron Temperature: 350°C +/- 5°C  
Heating Time: 5 seconds max.

**Note: These devices are not recommended for IR or Convection Reflow process.**

# Axial Lead & Cartridge Fuses

3AB > Slo-Blo® Fuse > 325/326 Series

**NO EXCEPTION TAKEN**

## Product Characteristics

<b>Materials</b>	Body: Ceramic Cap: Nickel-plated brass Leads: Tin-plated Copper
<b>Terminal Strength</b>	MIL-STD-202, Method 211, Test Condition A
<b>Solderability</b>	MIL-STD-202 Method 208
<b>Product Marking</b>	Cap1: Brand logo, current and voltage ratings Cap2: Series and agency approval marks

<b>Operating Temperature</b>	-55°C to +125°C
<b>Thermal Shock</b>	MIL-STD-202, Method 107, Test Condition B:(5 cycles - 65°C to 125°C)
<b>Vibration:</b>	MIL-STD-202, Method 201
<b>Humidity</b>	MIL-STD-202, Method 103, Test Condition A: High RH (95%) and Elevated temperature(40°C) for 240 hours
<b>Salt Spray</b>	MIL-STD-202, Method 101, Test Condition B

## Dimensions

Measurements displayed in millimeters (inches)

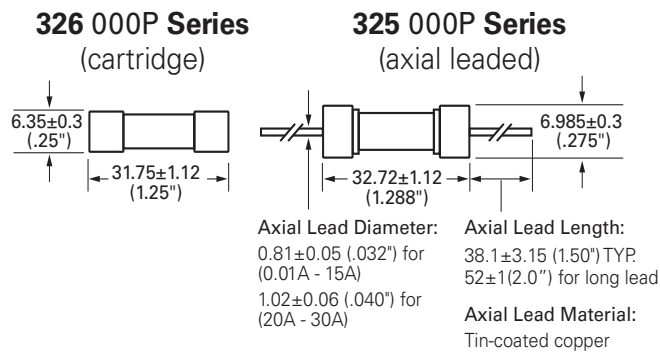

## Part Numbering System

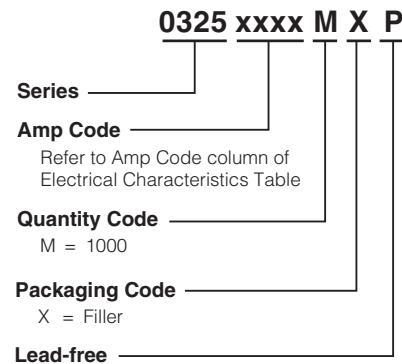

## Packaging

Packaging Option	Packaging Specification	Quantity	Quantity & Packaging Code	Taping Width
<b>325 Series</b>				
Bulk	N/A	5	VX	N/A
Bulk	N/A	100	HX	N/A
Bulk	N/A	1000	MX	N/A
Bulk	N/A	1000	MX52 (long lead)	N/A
Bulk	N/A	1000	MX52L (long lead)	N/A
Bulk	N/A	1000	MXD	N/A
Bulk	N/A	1000	MXF31	N/A
Bulk	N/A	1000	MXW	N/A
<b>326 Series</b>				
Bulk	N/A	5	VX	N/A
Bulk	N/A	100	HX	N/A
Bulk	N/A	1000	MX	N/A
Bulk	N/A	1000	MXCC	N/A
Bulk	N/A	1000	MXD	N/A

### Recommended Accessories

Accessory Type	Series	Description	Max Application Voltage	Max Application Amperage
Holder	<a href="#">155100</a>	Twist-Lock In-Line Fuseholder	32	20
	<a href="#">342</a>	Traditional Panel Mount Fuseholder	250	20
	<a href="#">346</a>	Panel Mount Flip-Top Shock-Safe Fuseholder	250	15
	<a href="#">345</a>	Shock-Safe Fuseholder with PC Mount, Solder Mount and Panel Mount options	250	20
Block	<a href="#">354</a>	Low Profile OMNI-BLOK® Fuse Block	600	30
	<a href="#">359</a>	High Current Screw Terminal Fuse Block		30
Clip	<a href="#">122</a>	High Current Traditional PC Board Fuse Clip	1000	30
	<a href="#">101</a>	Rivet/Eyelet Type Fuse Clip	1000	15

- Notes:
1. Do not use in applications above rating.
  2. Please refer to fuseholder data sheet for specific re-rating information.
  3. Please contact Littelfuse for applications greater than the max voltage and amperage shown.



Main

Range of product	Modicon X80
Product or component type	Discrete output module
Electrical connection	20-way connector
Discrete output number	8 conforming to EN/IEC 61131-2
Discrete output type	Relay
Discrete output voltage	12...24 V 10...34 V DC 24...240 V 10...264 V AC

Complementary

[I <sub>th</sub> ] conventional free air thermal current	3 A
Insulation resistance	> 10 MOhm 500 V DC
Power dissipation in W	<= 2.7 W
Response time on output	<= 10 ms activation <= 8 ms deactivation
Typical current consumption	100 mA at 3.3 V DC
MTBF reliability	1573341 H
Protection type	Overvoltage protection, inductive AC network Overvoltage protection, inductive DC network External overload protection External short-circuit protection
Output overload protection	Use 1 fast blow fuse per channel or group of channel
Output overvoltage protection	Use discharge diode on each output DC Use RC circuit on each output AC Use ZNO surge limiter on each output AC
Output short-circuit protection	Use 1 fast blow fuse per channel or group of channel
Minimum switching current	1 mA 5 V DC
Electrical durability	1000000 cycles AC-12 50 VA 48 V 1000000 cycles DC-12 24 W 24 V 1000000 cycles DC-13 24 W 24 V 2000000 cycles AC-15 24 VA 48 V 0.35

Disclaimer: This documentation is not intended as a substitute for and is not to be used for determining suitability or reliability of these products for specific user applications.

**STANTEC**  
**THIS PAGE ONLY**  
**NO EXCEPTION TAKEN**

2000000 cycles DC-13 10 W 24 V  
300000 cycles DC-12 40 W 24 V  
500000 cycles AC-12 110 VA 48 V  
500000 cycles AC-15 10 VA 48 V 0.35  
500000 cycles AC-15 24 VA 24 V 0.35  
700000 cycles AC-12 50 VA 24 V  
100000 cycles AC-15 220 VA 200...240 V 0.35  
1000000 cycles AC-12 110 VA 110...120 V  
1000000 cycles AC-12 220 VA 200...240 V  
1000000 cycles AC-15 110 VA 200...240 V 0.35  
10000000 cycles AC-15 10 VA 110...120 V 0.35  
10000000 cycles AC-15 10 VA 200...240 V 0.35  
150000 cycles AC-15 110 VA 110...120 V 0.35  
1500000 cycles AC-15 50 VA 110...120 V 0.35  
3000000 cycles AC-15 50 VA 200...240 V 0.35  
500000 cycles AC-12 220 VA 110...120 V

Status LED	1 LED green for module operating (RUN) 1 LED per channel green for channel diagnostic 1 LED red for module I/O 1 LED red for module error (ERR)
Product weight	0.145 kg

## Environment

IP degree of protection	IP20
Product certifications	CE CSA UL RCM Merchant Navy EAC
Standards	EN/IEC 61131-2 EN/IEC 61010-2-201 UL 61010-2-201 CSA C22.2 No 61010-2-201
Dielectric strength	2000 V AC at 50/60 Hz 1 min
Vibration resistance	3 gn
Shock resistance	30 gn
Ambient air temperature for storage	-40...85 °C
Ambient air temperature for operation	0...60 °C
Relative humidity	5...95 % without condensation 55 °C
Protective treatment	TC
Environmental characteristic	Corrosion resistance Dust resistant
Operating altitude	0...2000 m 2000...5000 m (with derating factor)

## Offer Sustainability

Sustainable offer status	Green Premium product
RoHS (date code: YYWW)	Compliant - since 0901 - Schneider Electric declaration of conformity <a href="#">Schneider Electric declaration of conformity</a>
REACH	Reference not containing SVHC above the threshold <a href="#">Reference not containing SVHC above the threshold</a>
Product environmental profile	Available <a href="#">End of life manual</a>
Product end of life instructions	Available

## Contractual warranty

Warranty period	18 months
-----------------	-----------

Modules Mounted on Racks

Dimensions

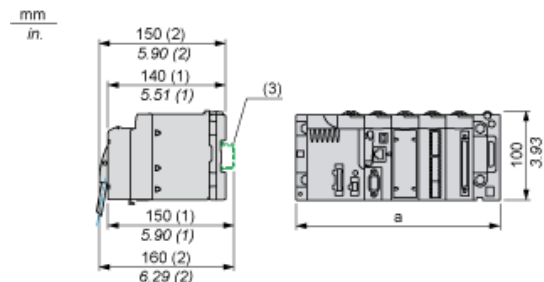

- (1) With removable terminal block (cage, screw or spring).
- (2) With FCN connector.
- (3) On AM1 ED rail: 35 mm wide, 15 mm deep. Only possible with BMXXBP0400/0400H/0600/0600H/0800/0800H rack.

Rack references	a in mm	a in in.
BMXXBP0400 and BMXXBP0400H	242.4	09.54
BMXXBP0600 and BMXXBP0600H	307.6	12.11
BMXXBP0800 and BMXXBP0800H	372.8	14.68
BMXXBP1200 and BMXXBP1200H	503.2	19.81

Connecting the Module

Output Circuit Diagram

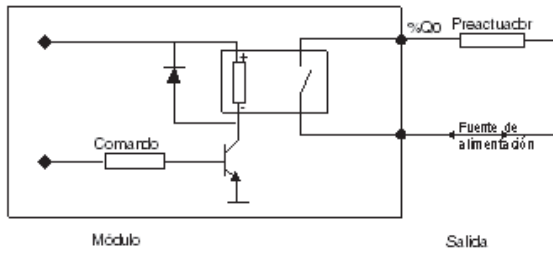

Module Connection

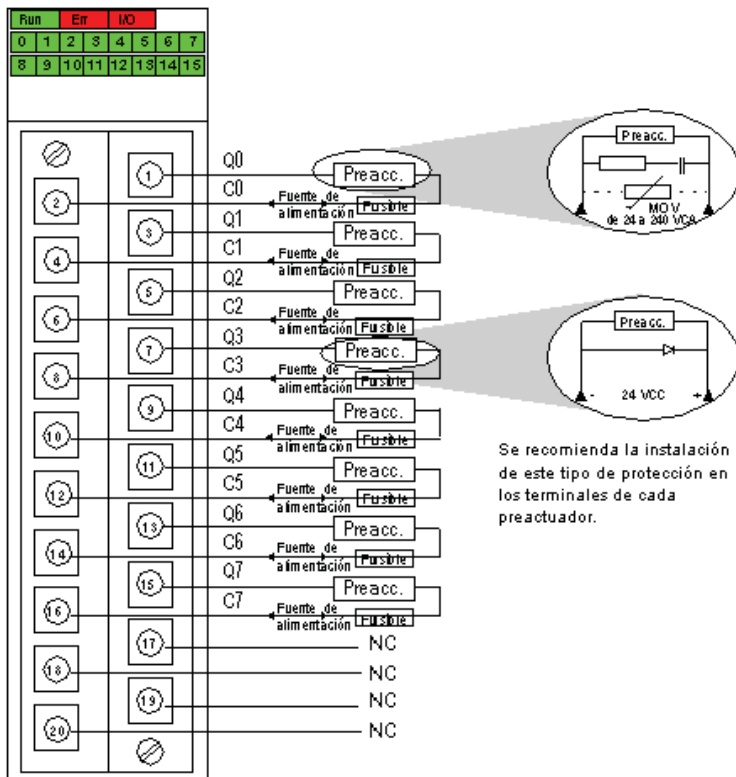

power supply 24VDC or 24...240 VAC  
fuse 1 fast blow fuse of 3 A for each relay  
NC not connected

Product availability : Stock - Normally stocked in distribution facility



Price\* : 341.00 USD



### Main

Range of product	Modicon X80
Product or component type	Discrete input module
Electrical connection	20-way connector
Discrete input number	16
Discrete input type	Isolated
Input type	Capacitive
Discrete input voltage	100...120 V AC
Discrete input current	5 mA
Input compatibility	With 2-wire/3-wire proximity sensors conforming to IEC 60947-5-2

### Complementary

Network frequency	50/60 Hz
Network frequency limits	47...63 Hz
Sensor power supply	20...26 V
Voltage state 1 guaranteed	$\geq 74$ V
Current state 1 guaranteed	$\geq 2.5$ mA
Voltage state 0 guaranteed	$\leq 20$ V
Current state 0 guaranteed	$\leq 1$ mA
Input impedance	13000 Ohm
Insulation resistance	$> 10$ MOhm 500 V DC
Power dissipation in W	$\leq 3.8$ W
AC activation filtering time	10 ms
AC deactivation filtering time	20 ms
Typical current consumption	90 mA at 3.3 V DC
MTBF reliability	1504958 H
Protection type	1 external fuse per group of channel 0.5 A fast blow

**STANTEC**  
**THIS PAGE ONLY**  
**NO EXCEPTION TAKEN**

Voltage detection threshold	< 40 V DC sensor fault > 82 V DC sensor OK
Status LED	1 LED green module operating (RUN) 1 LED per channel green channel diagnostic 1 LED red module I/O 1 LED red module error (ERR)
Product weight	0.25 lb(US) (0.115 kg)

## Environment

IP degree of protection	IP20
Product certifications	CE CSA UL RCM Merchant Navy EAC
Standards	EN/IEC 61131-2 EN/IEC 61010-2-201 UL 61010-2-201 CSA C22.2 No 61010-2-201
Dielectric strength	1500 V AC at 50/60 Hz 1 min
Vibration resistance	3 gn
Shock resistance	30 gn
Ambient air temperature for storage	-40...185 °F (-40...85 °C)
Ambient air temperature for operation	32...140 °F (0...60 °C)
Relative humidity	5...95 % without condensation 55 °C
Protective treatment	TC
Operating altitude	0...6561.68 ft (0...2000 m) 2000...5000 m (with derating factor)

## Ordering and shipping details

Category	18160 - MODICON M340
Discount Schedule	PC34
GTIN	00785901607595
Nbr. of units in pkg.	1
Package weight(Lbs)	0.35000000000000003
Returnability	Y
Country of origin	FR

## Offer Sustainability

Sustainable offer status	Green Premium product
RoHS (date code: YYWW)	Compliant - since 0805 - Schneider Electric declaration of conformity <a href="#">Schneider Electric declaration of conformity</a>
REACH	Reference not containing SVHC above the threshold <a href="#">Reference not containing SVHC above the threshold</a>
Product environmental profile	Available
Product end of life instructio	Available

## Contractual warranty

Period	18 months
--------	-----------

Modules Mounted on Racks

Dimensions

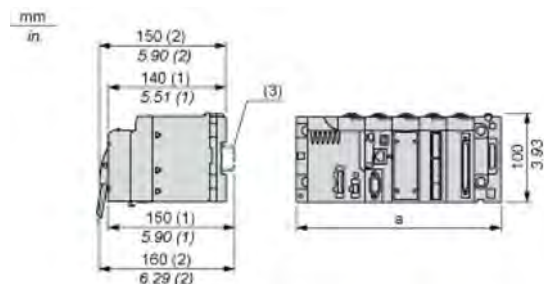

- (1) With removable terminal block (cage, screw or spring).
- (2) With FCN connector.
- (3) On AM1 ED rail: 35 mm wide, 15 mm deep. Only possible with BMXXBP0400/0400H/0600/0600H/0800/0800H rack.

Rack references	a in mm	a in in.
BMXXBP0400 and BMXXBP0400H	242.4	09.54
BMXXBP0600 and BMXXBP0600H	307.6	12.11
BMXXBP0800 and BMXXBP0800H	372.8	14.68
BMXXBP1200 and BMXXBP1200H	503.2	19.81

Connecting the Module

Input Circuit Diagram

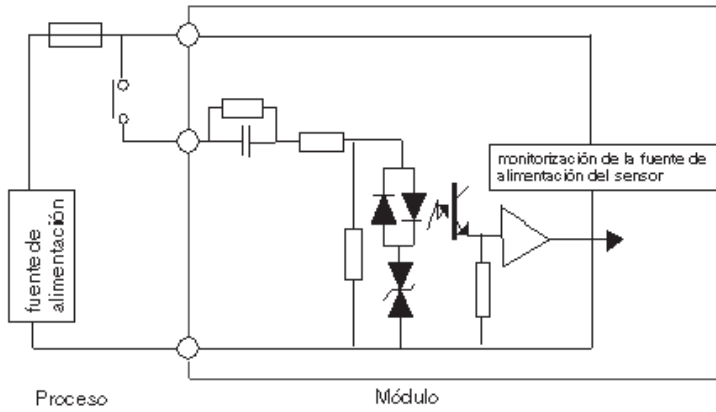

Module Connection

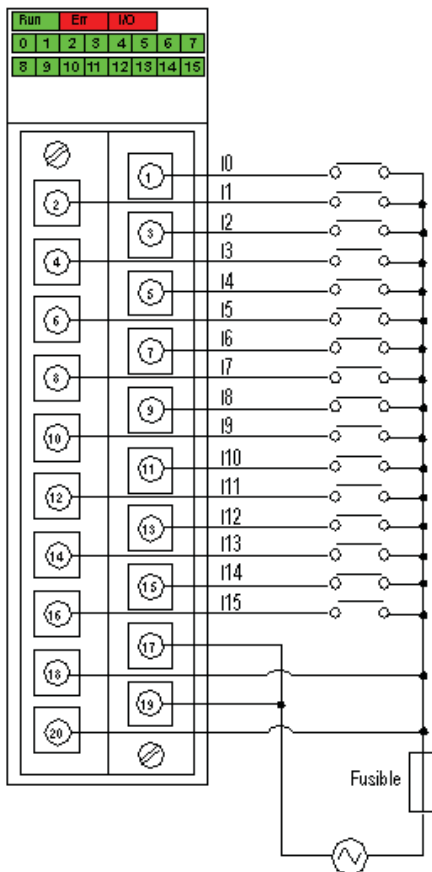

power supply 100...120 VAC  
fuse fast blow fuse of 0.5 A



### Main

Range of product	Modicon X80
Product or component type	Analog output module
Electrical connection	1 connector 20 ways
Input output isolation	Non isolated

### Complementary

Measurement error	$\leq 0.25\%$ of full scale 0...60 °C 0.1 % of full scale 25 °C
Temperature drift	45 ppm/°C 0...20 mA 45 ppm/°C 4...20 mA
Common mode between channels	$\geq 80$ dB
Isolation voltage	1400 V DC between channels and ground 1400 V DC between channels and bus
Detection type	Open circuit 4...20 mA Short circuit 0...20 mA
Load impedance ohmic	$\leq 350$ Ohm 0...20 mA $\leq 350$ Ohm 4...20 mA
Output level	High level
Analogue output number	8
Analogue output type	Current 0...20 mA Current 4...20 mA
Analogue output resolution	15 bits + sign
Supply	Internal power supply via rack
Conversion time	$\leq 4$ ms
Maximum conversion value	0...21 mA 0...20 mA 0...21 mA 4...20 mA
Fallback mode	Configurable Predefined
Status LED	1 LED green RUN 1 LED per channel green channel diagnostic 1 LED red ERR 1 LED red I/O

Disclaimer: This documentation is not intended as a substitute for and is not to be used for determining suitability or reliability of these products for specific user applications

Product weight	0.15 kg
Current consumption	150 mA at 3.3 V DC 74 mA at 24 V DC

**STANTEC**  
**THIS PAGE ONLY**  
**NO EXCEPTION TAKEN**

SUBMITTAL  
Do Not Use  
For Installation

### Environment

Vibration resistance	3 gn
Shock resistance	30 gn
Ambient air temperature for storage	-40...85 °C
Ambient air temperature for operation	0...60 °C
Relative humidity	5...95 % 55 °C without condensation
IP degree of protection	IP20
Product certifications	CE CSA UL RCM Merchant Navy EAC
Standards	EN/IEC 61131-2 EN/IEC 61010-2-201 UL 61010-2-201 CSA C22.2 No 61010-2-201
Protective treatment	TC
Operating altitude	0...2000 m 2000...5000 m (with derating factor)

### Offer Sustainability

Sustainable offer status	Green Premium product
RoHS (date code: YYWW)	Compliant - since 0901 - Schneider Electric declaration of conformity <a href="#">Schneider Electric declaration of conformity</a>
REACH	Reference not containing SVHC above the threshold <a href="#">Reference not containing SVHC above the threshold</a>
Product environmental profile	Available <a href="#">End of life manual</a>
Product end of life instructions	Available <a href="#">End of life manual</a>

### Contractual warranty

Warranty period	18 months
-----------------	-----------

Modules Mounted on Racks

Dimensions

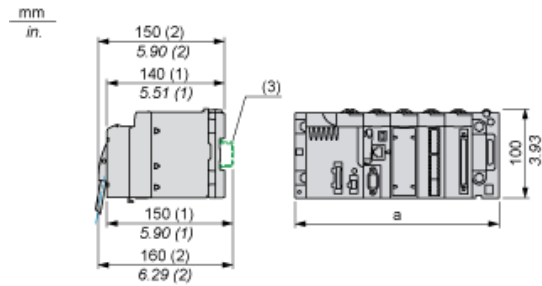

- (1) With removable terminal block (cage, screw or spring).
- (2) With FCN connector.
- (3) On AM1 ED rail: 35 mm wide, 15 mm deep. Only possible with BMXXBP0400/0400H/0600/0600H/0800/0800H rack.

Rack references	a in mm	a in in.
BMXXBP0400 and BMXXBP0400H	242.4	09.54
BMXXBP0600 and BMXXBP0600H	307.6	12.11
BMXXBP0800 and BMXXBP0800H	372.8	14.68
BMXXBP1200 and BMXXBP1200H	503.2	19.81

Wiring Diagram

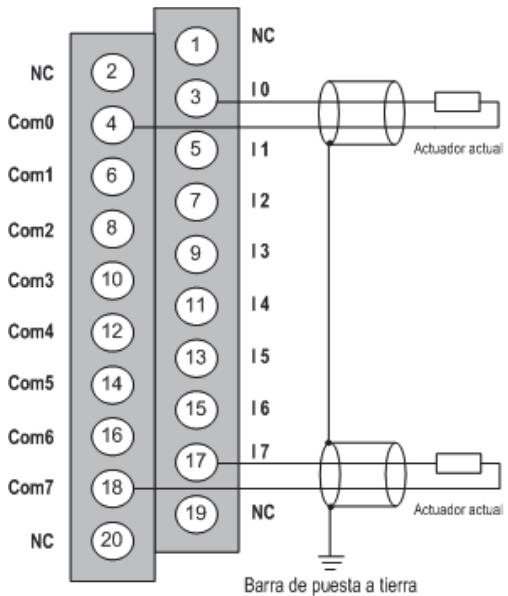

Ix + pole input for channel x.

COMx - pole input for channel x, COMx are connected together internally.

The current loop is self-powered by the output and does not request any external supply.



### Main

Range of product	Modicon X80
Product or component type	Analog input module
Electrical connection	1 connector 28 ways
Input output isolation	Isolated
Input level	High level
Analogue input number	8
Analogue input type	Current +/- 20 mA Current 0...20 mA Current 4...20 mA Voltage +/- 10 V Voltage +/- 5 V Voltage 0...10 V Voltage 0...5 V Voltage 1...5 V

### Complementary

Analog/Digital conversion	16 bits
Analogue input resolution	15 bits + sign
Input impedance	10 MOhm
Permitted overload on inputs	+/- 30 mA 0...20 mA +/- 30 mA 4...20 mA +/- 30 V +/- 10 V +/- 30 V +/- 5 V +/- 30 V 0...10 V +/- 30 V 0...5 V +/- 30 V 1...5 V +/- 30 mA +/- 20 mA
Internal conversion resistor	250 Ohm
Precision of internal conversion resistor	0.1 % - 15 ppm/°C
Type of filter	First order digital filtering
Fast read cycle time	1 ms + 1 ms x number of channels used
Nominal read cycle time	9 ms for 8 channels

**STANTEC**  
**THIS PAGE ONLY**  
**NO EXCEPTION TAKEN**

Measurement error	<= 0.1 % of full scale +/- 10 V 0...60 °C <= 0.1 % of full scale +/- 5 V 0...60 °C <= 0.1 % of full scale 0...10 V 0...60 °C <= 0.1 % of full scale 0...5 V 0...60 °C <= 0.1 % of full scale 1...5 V 0...60 °C <= 0.3 % of full scale +/- 20 mA 0...60 °C <= 0.3 % of full scale 0...20 mA 0...60 °C <= 0.3 % of full scale 4...20 mA 0...60 °C 0.15 % of full scale +/- 20 mA 25 °C 0.15 % of full scale 0...20 mA 25 °C 0.15 % of full scale 4...20 mA 25 °C 0.08 % of full scale +/- 10 V 25 °C 0.08 % of full scale 0...10 V 25 °C 0.08 % of full scale 0...5 V 25 °C 0.08 % of full scale 1...5 V 25 °C 0.08 % of full scale +/- 5 V 25 °C <= 0.2 % of full scale +/- 10 V 0...60 °C
Temperature drift	30 ppm/°C 50 ppm/°C
Common mode between channels	>= 80 dB
Digital value format	+/- 10000 by default +/- 32000 in user scale
Isolation voltage	300 V DC between channels 1400 V DC between channels and ground 1400 V DC between channels and bus
Measurement resolution	0.36 mV +/- 10 V 0.36 mV 0...10 V 0.36 mV 0...5 V 0.36 mV 1...5 V 0.36 mV +/- 5 V 1.4 µA +/- 20 mA 1.4 µA 0...20 mA 1.4 µA 4...20 mA
Maximum conversion value	+/- 11.4 V +/- 10 V +/- 11.4 V 0...10 V +/- 11.4 V 0...5 V +/- 11.4 V 1...5 V 0...30 mA +/- 20 mA 0...30 mA 0...20 mA 0...30 mA 4...20 mA 0...30 mA +/- 5 V
Status LED	1 LED green RUN 1 LED per channel green channel diagnostic 1 LED red ERR 1 LED red I/O
Product weight	0.165 kg
Current consumption	150 mA at 3.3 V DC 45 mA at 24 V DC

## Environment

Vibration resistance	3 gn
Shock resistance	30 gn
Ambient air temperature for storage	-40...85 °C
Ambient air temperature for operation	0...60 °C
Relative humidity	5...95 % 55 °C without condensation
IP degree of protection	IP20
Product certifications	CE CSA UL RCM Merchant Navy EAC
Standards	EN/IEC 61131-2 EN/IEC 61010-2-201 UL 61010-2-201 CSA C22.2 No 61010-2-201

Protective treatment	TC	<b>STANTEC</b> <b>THIS PAGE ONLY</b> <b>NO EXCEPTION TAKEN</b>
Operating altitude	0...2000 m 2000...5000 m (with derating factor)	

### Offer Sustainability

Sustainable offer status	Green Premium product
RoHS (date code: YYWW)	Compliant - since 0901 - Schneider Electric declaration of conformity <a href="#">Schneider Electric declaration of conformity</a>
REACH	Reference not containing SVHC above the threshold <a href="#">Reference not containing SVHC above the threshold</a>
Product environmental profile	Available <a href="#">End of life manual</a>
Product end of life instructions	Available <a href="#">End of life manual</a>

### Contractual warranty

Warranty period	18 months
-----------------	-----------

Modules Mounted on Racks

Dimensions

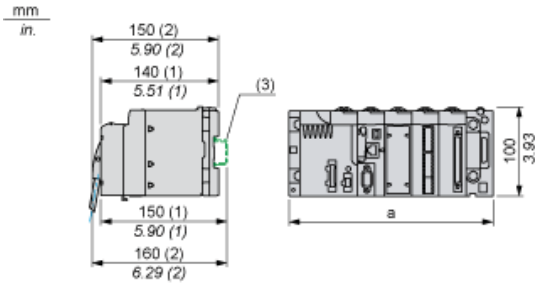

- (1) With removable terminal block (cage, screw or spring).
- (2) With FCN connector.
- (3) On AM1 ED rail: 35 mm wide, 15 mm deep. Only possible with BMXXBP0400/0400H/0600/0600H/0800/0800H rack.

Rack references	a in mm	a in in.
BMXXBP0400 and BMXXBP0400H	242.4	09.54
BMXXBP0600 and BMXXBP0600H	307.6	12.11
BMXXBP0800 and BMXXBP0800H	372.8	14.68
BMXXBP1200 and BMXXBP1200H	503.2	19.81

Wiring Diagram

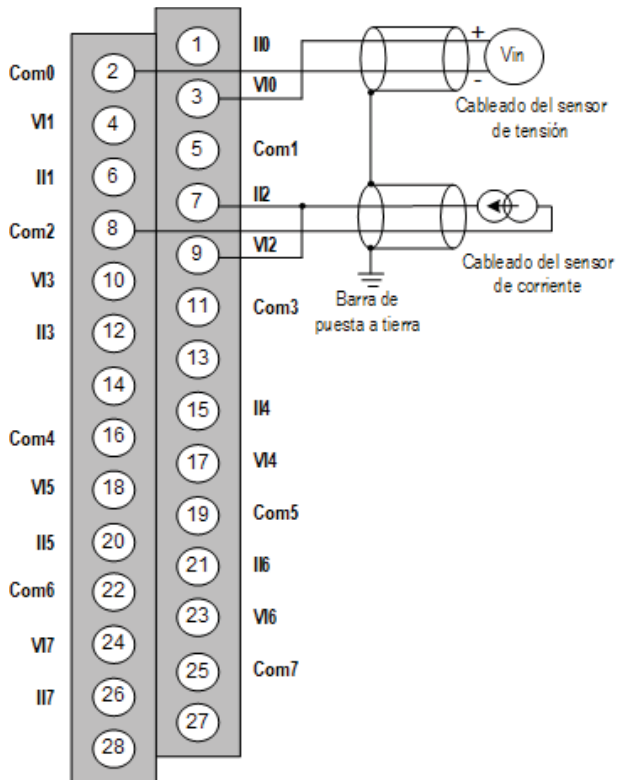

V1x + pole input for channel x  
 COM x - pole input for channel x  
 IIx current reading resistor + input  
 Channel 0 voltage sensor  
 Channel 12-wire current sensor



### Main

Range of product	Modicon M340 automation platform
Accessory / separate part type	Removable connection block
Number of terminals	20 removable screw clamp terminal block
Accessory / separate part destination	For module with 20-way removable terminal block

### Complementary

Product weight	0.075 kg
----------------	----------

### Offer Sustainability

Sustainable offer status	Green Premium product
RoHS (date code: YYWW)	Compliant - since 1036 - Schneider Electric declaration of conformity <a href="#">Schneider Electric declaration of conformity</a>
REACH	Reference not containing SVHC above the threshold <a href="#">Reference not containing SVHC above the threshold</a>
Product environmental profile	Available <a href="#">End of life manual</a>
Product end of life instructions	Available

### Contractual warranty

Warranty period	18 months
-----------------	-----------

Disclaimer: This documentation is not intended as a substitute for and is not to be used for determining suitability or reliability of these products for specific user applications.

Product availability : Stock - Normally stocked in distribution facility



Price\* : 56.00 USD



### Main

Range of product	Modicon M340 automation platform
Accessory / separate part type	Removable connection block
Number of terminals	28 removable spring terminal block
Accessory / separate part destination	For module with 28-way removable terminal block

### Complementary

Product weight	0.15 lb(US) (0.07 kg)
----------------	-----------------------

### Ordering and shipping details

Category	18160 - MODICON M340
Discount Schedule	PC34
GTIN	00785901628859
Nbr. of units in pkg.	1
Package weight(Lbs)	0.19
Returnability	Y
Country of origin	CN

### Offer Sustainability

Sustainable offer status	Green Premium product
RoHS (date code: YYWW)	Compliant - since 1036 - Schneider Electric declaration of conformity <a href="#">Schneider Electric declaration of conformity</a>
REACH	Reference not containing SVHC above the threshold Reference not containing SVHC above the threshold
Product environmental profile	Available
Product end of life instructions	Available

Contractual warranty

Warranty period 18 months

**STANTEC**  
**THIS PAGE ONLY**  
**NO EXCEPTION TAKEN**

SUBMITTAL  
Do Not Use  
For Installation

Product availability : Stock - Normally stocked in distributor facility



Price\* : 2325.00 USD



**Main**

Range of product	Modicon M340 automation platform
Product or component type	Processor module
Concept	CANopen Transparent Ready
Number of racks	4
Number of slots	11
Discrete I/O processor capacity	1024 I/O multi-rack configuration 704 I/O single-rack configuration
Analogue I/O processor capacity	256 I/O multi-rack configuration 66 I/O single-rack configuration
Number of application specific channel	36
Monitoring	Diagnostic counters Modbus Event counters Modbus

**Complementary**

Control channels	Programmable loops
Integrated connection type	Ethernet TCP/IP RJ45 10/100 Mbit/s 1 twisted pair USB port 12 Mbit/s Non isolated serial link RJ45 character mode asynchronous in baseband RS232C full duplex 0.3...19.2 kbit/s 2 twisted shielded pairs Non isolated serial link RJ45 character mode asynchronous in baseband RS485 half duplex 0.3...19.2 kbit/s 1 twisted shielded pair Non isolated serial link RJ45 Modbus master/slave RTU/ASCII asynchronous in baseband RS232C half duplex 0.3...19.2 kbit/s 1 twisted shielded pair Non isolated serial link RJ45 Modbus master/slave RTU/ASCII asynchronous in baseband RS485 half duplex 0.3...19.2 kbit/s 1 twisted shielded pair
Communication module processor capacity	2 Ethernet communication module 4 AS-Interface module
Communication service	Bandwidth management, Ethernet TCP/IP Data Editor, Ethernet TCP/IP Modbus TCP messaging, Ethernet TCP/IP Rack Viewer, Ethernet TCP/IP SNMP network administrator, Ethernet TCP/IP
Port Ethernet	10BASE-T/100BASE-TX

**STANTEC**  
**THIS PAGE ONLY**  
**NO EXCEPTION TAKEN**

Number of devices per segment	0...32 character mode 0...32 Modbus
Number of devices	2 point-to-point character mode 2 point-to-point Modbus
Bus length	0...32.81 ft (0...10 m) serial link non isolated character mode segment 0...32.81 ft (0...10 m) serial link non isolated Modbus segment 0...3280.84 ft (0...1000 m) serial link isolated character mode segment 0...3280.84 ft (0...1000 m) serial link isolated Modbus segment 0...49.21 ft (0...15 m) character mode point-to-point 0...49.21 ft (0...15 m) Modbus point-to-point
Tap links length	15 m serial link non isolated character mode segment 15 m serial link non isolated Modbus segment 40 m serial link isolated character mode segment 40 m serial link isolated Modbus segment
Number of addresses	0...248 character mode 0...248 Modbus
Requests	1 K data bytes per request character mode 252 data bytes per RTU request Modbus 504 data bytes per ASCII request Modbus
Control parameter	One CRC on each frame (RTU) Modbus One LRC on each frame (ASCII) character mode One LRC on each frame (ASCII) Modbus
Memory description	4096 kB internal RAM 256 kB internal RAM data 3584 kB internal RAM program constants and symbols Supplied memory card (BMXRMS008MP) activation of standard web server, class B10 Supplied memory card (BMXRMS008MP) backup of programs, constants, symbols and data
Maximum size of object areas	256 kB unlocated internal data 32634 %Mi located internal bits
Default size of object areas	1024 %MWi internal words located internal data 256 %KWi constant words located internal data 512 %Mi located internal bits
Application structure	1 cyclic/periodic master task 1 periodic fast task 64 event tasks No auxiliary task
Execution time per instruction	0.12 µs Boolean 0.17 µs double-length words 0.25 µs single-length words 1.16 µs floating points
Number of instructions per ms	6.4 Kinst/ms 65 % Boolean + 35 % fixed arithmetic 8.1 Kinst/ms 100 % Boolean
System overhead	0.13 ms fast task 0.7 ms master task
Current consumption	95 mA 24 V DC
Supply	Internal power supply via rack
Marking	CE
Status LED	1 LED green activity on Ethernet network (ETH ACT) 1 LED green processor running (RUN) 1 LED green status of Ethernet network (ETH STS) 1 LED red data rate (ETH 100) 1 LED red I/O module fault (I/O) 1 LED red memory card fault (CARD ERR) 1 LED red processor or system fault (ERR) 1 LED yellow activity on Modbus (SER COM)
Product weight	0.45 lb(US) (0.205 kg)

## Environment

Ambient air temperature for operation	32...140 °F (0...60 °C)
Relative humidity	10...95 % without condensation
IP degree of protection	IP20
Protective treatment	TC
Standards	CSA C22.2 No 142 EN 61131-2

**STANTEC**  
**THIS PAGE ONLY**  
**NO EXCEPTION TAKEN**

### Ordering and shipping details

Category	18160 - MODICON M340
Discount Schedule	PC34
GTIN	00785901476542
Nbr. of units in pkg.	1
Package weight(Lbs)	0.530000000000000003
Returnability	Y
Country of origin	FR

### Offer Sustainability

Sustainable offer status	Green Premium product
RoHS (date code: YYWW)	Compliant - since 0722 - Schneider Electric declaration of conformity <a href="#">Schneider Electric declaration of conformity</a>
REACH	Reference not containing SVHC above the threshold <a href="#">Reference not containing SVHC above the threshold</a>
Product environmental profile	Available
Product end of life instructions	Available

### Contractual warranty

Warranty period	18 months
-----------------	-----------

Modules Mounted on Racks

Dimensions

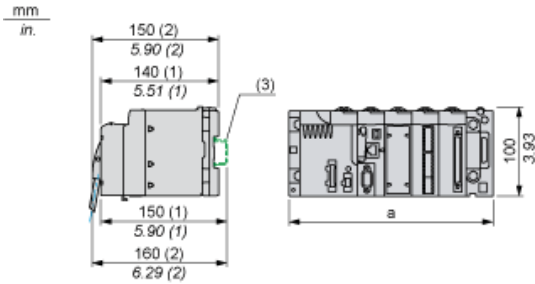

- (1) With removable terminal block (cage, screw or spring).
- (2) With FCN connector.
- (3) On AM1 ED rail: 35 mm wide, 15 mm deep. Only possible with BMXXBP0400/0400H/0600/0600H/0800/0800H rack.

Rack references	a in mm	a in in.
BMXXBP0400 and BMXXBP0400H	242.4	09.54
BMXXBP0600 and BMXXBP0600H	307.6	12.11
BMXXBP0800 and BMXXBP0800H	372.8	14.68
BMXXBP1200 and BMXXBP1200H	503.2	19.81



### Main

Range of product	Modicon M340 automation platform
Accessory / separate part type	Rack

### Complementary

Number of slots	8 bus X
Product compatibility	BMXCPS power supply BMXP34 processor I/O module Specific application module
Power consumption in W	2 W
Electrical connection	1 connector (XBE) expansion module
Fixing mode	By 4 M6 screws plate By clips 35 mm symmetrical DIN rail By 4 screws 4.32...6.35 mm panel
Product weight	0.95 kg

### Environment

IP degree of protection	IP20
Ambient air temperature for operation	0...60 °C
Relative humidity	10...95 % without condensation
Protective treatment	TC

### Offer Sustainability

Sustainable offer status	Green Premium product
RoHS (date code: YYWW)	Compliant - since 0612 - Schneider Electric declaration of conformity <a href="#">Schneider Electric declaration of conformity</a>
REACH	Reference not containing SVHC above the threshold <a href="#">Reference not containing SVHC above the threshold</a>

Product environmental profile Available  
 Product environmental

**STANTEC  
THIS PAGE ONLY  
NO EXCEPTION TAKEN**

Product end of life instructions Available  
 End of life manual

**Contractual warranty**

Warranty period 18 months

Dimensions

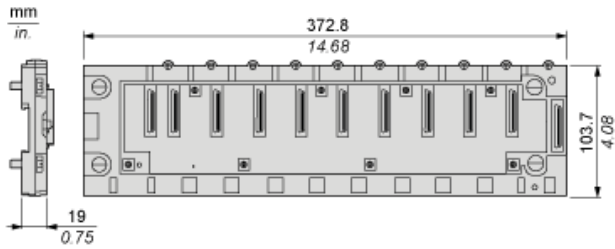

Rack Installation in a Cabinet

Minimum Clearance

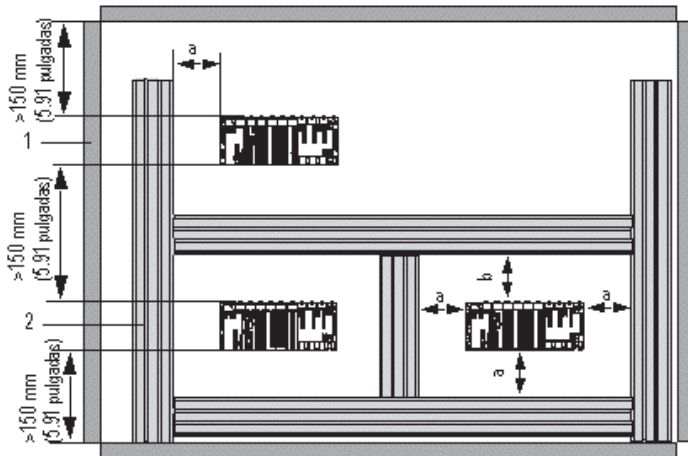

a Greater than or equal to 60 mm (2.36 in.)

b Greater than or equal to 80 mm (3.15 in.)

1 Installation or casing

2 Wiring duct or tray

Mounting and Fastening the Racks

Mounting on 35 mm (1.38 in.) Wide and 15 mm (0.59 in.) Deep DIN Rails with Four HM6 Screws

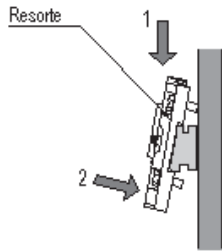

Mounting on Panels

Dimensions in mm / in.

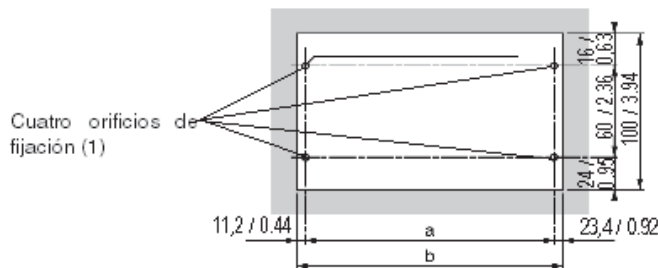

(1) The diameter of the fastening holes must allow use of M4, M5, M6 and UNC #6 screws.

Rack	a	b	Size of the rack and extension module
BMXXBP040 and BMXXBP0400H	207.8 mm (8.187 in.)	242.2 mm (9.543 in.)	243.4 mm (9.59 in.)
BMXXBP0600 and BMXXBP0600H	273 mm (10.756 in.)	307.6 mm (12.12 in.)	308.8 mm (12.167 in.)
BMXXBP0800 and BMXXBP0800H	338.2 mm (13.325 in.)	372.8 mm (14.69 in.)	374 mm (14.736 in.)
BMXXBP1200 and BMXXBP1200H	468.6 mm (18.463 in.)	503.2 mm (19.826 in.)	504.4 mm (19.873 in.)

Mounting on Telequick AM1-PA and AM3-PA Mounting Grids

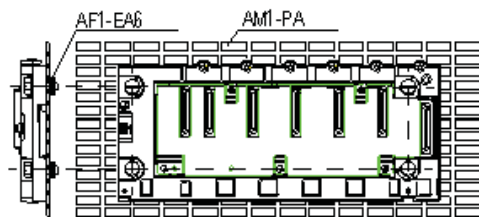

Fasten the rack with four M4, M5, M6 or UNC #6 screws.



### Main

Range of product	Modicon X80
Product or component type	Peripheral remote I/O adaptor

### Complementary

Number of port	1
Integrated connection type	Ethernet/IP for device network
Communication port protocol	Modbus TCP
Realtime clock	With
Memory capacity	448 kB internal memory 96 kB removable memory
Application structure	1 master task
Local signalling	1 LED green for Ethernet network status (link) 1 LED red for external fault (I/O) 1 LED green for activity on Ethernet network (ETH ACT) 1 LED red for memory card fault (CARD ERR) 1 LED green for Ethernet link diagnostics (STS) 1 LED green for module active (RUN) 1 LED red for module error (ERR)
Product compatibility	0...1024 discrete I/O module 0...256 analog I/O module 0...2 Ethernet module
Average consumption in mA	95 mA
Power dissipation in W	2.3 W
Marking	CE
Module format	Standard

### Environment

Environmental characteristic	Standard environment
Product certifications	C-Tick GOST

**THIS PAGE ONLY  
NO EXCEPTION TAKEN**

Standards	CSA C22.2 No 142 EN 61131-2 UL 1604 UL 508 CSA C22.2 No 213
IP degree of protection	IP20
Ambient air temperature for operation	-25...70 °C
Ambient air temperature for storage	-40...85 °C
Operating altitude	<= 2000 m
Altitude transport	<= 3000 m
Relative humidity	95 % without condensation

**Offer Sustainability**

Sustainable offer status	Green Premium product
RoHS (date code: YYWW)	Compliant - since 0901 - Schneider Electric declaration of conformity <a href="#">Schneider Electric declaration of conformity</a>
REACH	Reference not containing SVHC above the threshold <a href="#">Reference not containing SVHC above the threshold</a>
Product environmental profile	Available <a href="#">Product environmental</a>
Product end of life instructions	Available <a href="#">End of life manual</a>





### Main

Range of product	Modicon X80
Product or component type	Power supply module
Product compatibility	Not compatible with BMEXBP..02
Primary voltage	24 V isolated
Supply circuit type	DC
Secondary power	16.8 W 24 V DC I/O module power supply and processor 8.3 W 3.3 V DC I/O module logic power supply

### Complementary

Primary voltage limit	18...31.2 V
Input current	1 A 24 V
Inrush current	30 A 24 V
I <sup>2</sup> t on activation	0.6 A <sup>2</sup> .s 24 V
It on activation	<= 0.15 A.s 24 V
Protection type	Internal fuse not accessible primary circuit Overload protection secondary circuit, 24 V sensor power supply Overvoltage protection secondary circuit, 24 V sensor power supply Short-circuit protection secondary circuit, 24 V sensor power supply
Current at secondary voltage	0.7 A 24 V DC I/O module power supply and processor 2.5 A 3.3 V DC I/O module logic power supply
Power dissipation in W	<= 8.5 W
Status LED	1 LED green rack voltage OK
Control type	RESET push-button cold restart
Electrical connection	1 connector 2 pin(s) alarm relay 1 connector 5 pin(s) line supply, protective earth, 24 V DC input sensor
Cable distance between devices	20 m power supply cable copper 1.5 mm <sup>2</sup> 30 m power supply cable copper 2.5 mm <sup>2</sup>
Insulation resistance	>= 10 mOhm primary/secondary >= 10 mOhm primary/ground
Product weight	0.29 kg

Disclaimer: This documentation is not intended as a substitute for and is not to be used for determining suitability or reliability of these products for specific user applications

**STANTEC**  
**THIS PAGE ONLY**

**NO EXCEPTION TAKEN**

## Environment

Immunity to microbreaks	1 ms
Dielectric strength	1500 V primary/ground 1500 V primary/secondary
Vibration resistance	3 gn
Shock resistance	30 gn
IP degree of protection	IP20
Product certifications	CE CSA UL RCM Merchant Navy EAC
Standards	EN/IEC 61131-2 EN/IEC 61010-2-201 UL 61010-2-201 CSA C22.2 No 61010-2-201
Ambient air temperature for storage	-40...85 °C
Ambient air temperature for operation	0...60 °C
Relative humidity	5...95 % without condensation 55 °C
Protective treatment	TC
Operating altitude	0...2000 m 2000...5000 m (with derating factor)

## Offer Sustainability

Sustainable offer status	Green Premium product
RoHS (date code: YYWW)	Compliant - since 0722 - Schneider Electric declaration of conformity <a href="#">Schneider Electric declaration of conformity</a>
REACH	Reference not containing SVHC above the threshold <a href="#">Reference not containing SVHC above the threshold</a>
Product environmental profile	Available <a href="#">Product environmental</a>
Product end of life instructions	Available <a href="#">End of life manual</a>

## Contractual warranty

Warranty period	18 months
-----------------	-----------

Modules Mounted on Racks

Dimensions

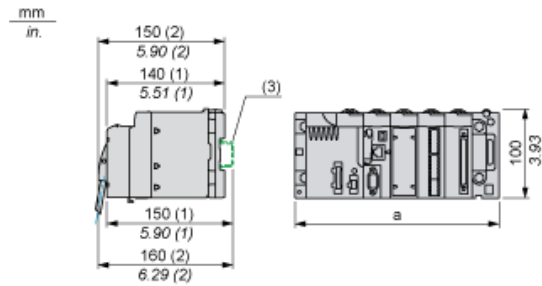

- (1) With removable terminal block (cage, screw or spring).
- (2) With FCN connector.
- (3) On AM1 ED rail: 35 mm wide, 15 mm deep. Only possible with BMXXBP0400/0400H/0600/0600H/0800/0800H rack.

Rack references	a in mm	a in in.
BMXXBP0400 and BMXXBP0400H	242.4	09.54
BMXXBP0600 and BMXXBP0600H	307.6	12.11
BMXXBP0800 and BMXXBP0800H	372.8	14.68
BMXXBP1200 and BMXXBP1200H	503.2	19.81

## Connection of Direct Current Power Supply Modules to a 24 Vdc or 48 Vdc Floating Direct Current Network

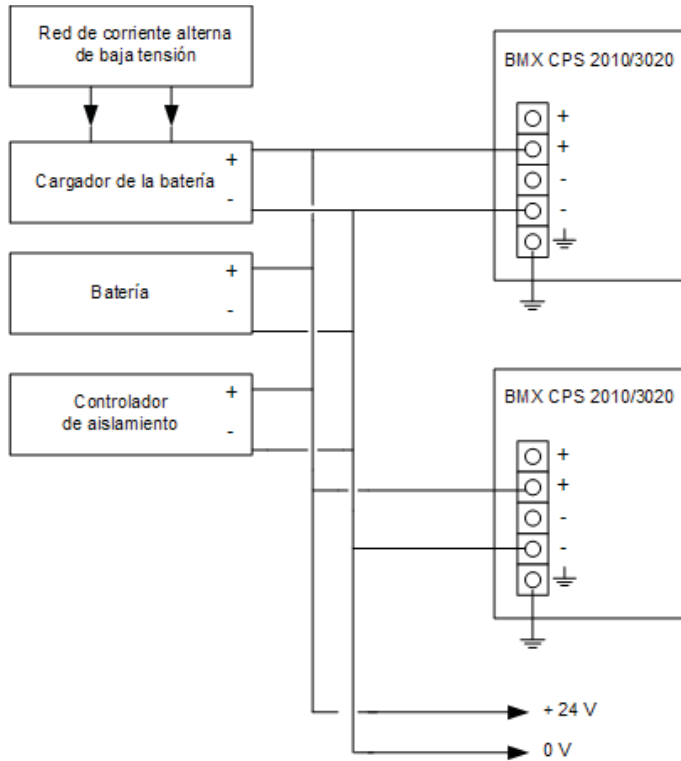

Red flotante de 24 V CC para la alimentación de sensores, actuadores y módulos de entrada/salida.

Connection of Direct Current Power Supply Modules to an Alternating Current Network

Connection of a Single Rack PLC Station

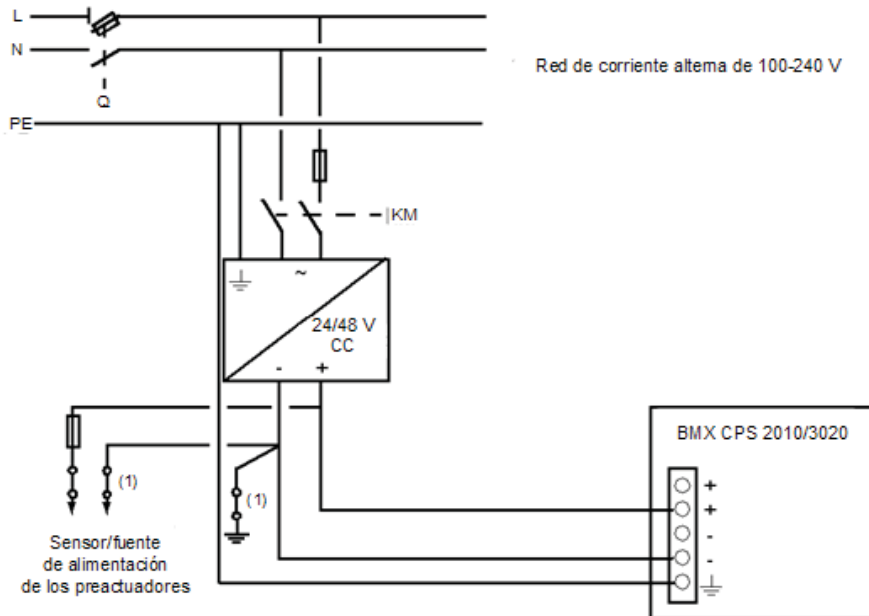

- Q General isolator
- KM Line contactor or circuit breaker
- (1) Insulation connector bar for locating grounding errors

**STANTEC**  
**THIS PAGE ONLY**  
**NO EXCEPTION TAKEN**

### Connection of a Multi-Rack PLC Station

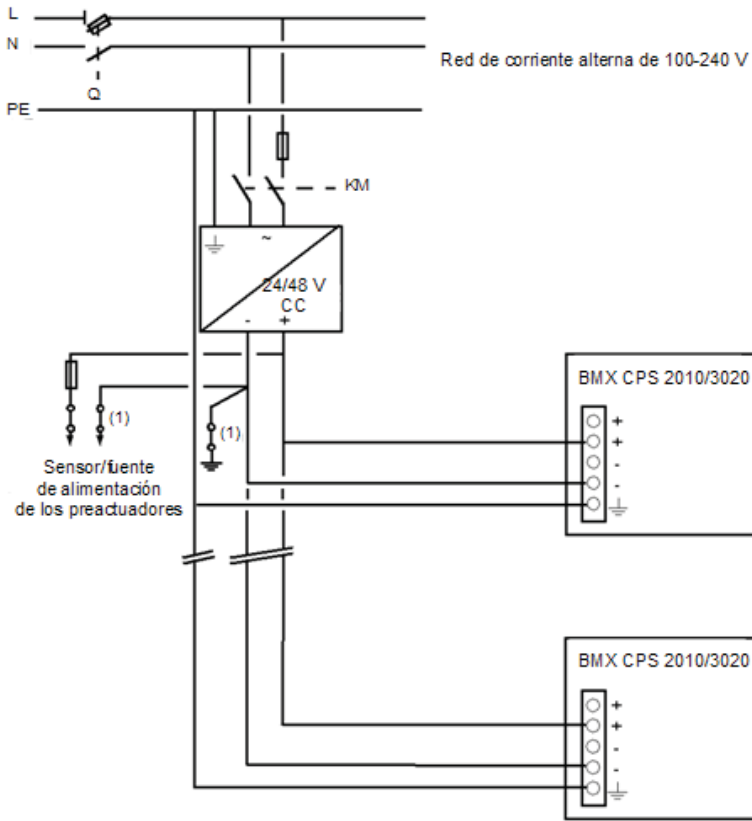

- Q General isolator
- KM Line contactor or circuit breaker
- (1) Insulation connector bar for locating grounding errors



### Main

Range of product	Modicon M340 automation platform
Accessory / separate part category	Protection accessories
Accessory / separate part type	Cover
Accessory / separate part designation	Protective cover
Product compatibility	BMXXBP0400 BMXXBP0600 BMXXBP0800 BMXXBP1200
Accessory / separate part destination	Unoccupied slots on rack
Quantity per set	Set of 5

### Complementary

Product weight	0.005 kg
----------------	----------

### Offer Sustainability

Sustainable offer status	Green Premium product
RoHS (date code: YYWW)	Compliant - since 1508 - Schneider Electric declaration of conformity <a href="#">Schneider Electric declaration of conformity</a>
REACH	Reference not containing SVHC above the threshold <a href="#">Reference not containing SVHC above the threshold</a>
Product environmental profile	Available <a href="#">End of life manual</a>
Product end of life instructions	Available

### Contractual warranty

Warranty period	18 months
-----------------	-----------

**STANTEC**  
**THIS PAGE ONLY**  
**NO EXCEPTION TAKEN**

# EDS-505A/508A/516A Series

*5, 8, and 16-port managed Ethernet switches*



- > Turbo Ring and Turbo Chain (recovery time < 20 ms @ 250 switches), RSTP/STP, and MSTP for network redundancy
- > TACACS+, SNMPv3, IEEE 802.1X, HTTPS, and SSH to enhance network security
- > Easy network management by web browser, CLI, Telnet/serial console, Windows utility, and ABC-01
- > Supports MXstudio for easy, visualized industrial network management



## Introduction

The EDS-505A/508A/516A are standalone 5, 8, and 16-port managed Ethernet switches. With their advanced Turbo Ring and Turbo Chain technology (recovery time < 20 ms), RSTP/STP, and MSTP support the EDS-505A/508A/516A switches increase the reliability and availability of your industrial Ethernet network. Models with an wide operating

temperature range of -40 to 75°C are also available, and the switches support advanced management and security features, making the EDS-505A/508A/516A switches suitable for any harsh industrial environment.

## Features and Benefits

- Command Line Interface (CLI) for quickly configuring major managed functions
- IPv6 Ready logo awarded (IPv6 Logo Committee certified)
- Software-based IEEE 1588 PTPv2 (Precision Time Protocol) for time synchronization of networks
- DHCP Option 82 for IP address assignment with different policies
- Support EtherNet/IP and Modbus/TCP protocols for device management and monitoring
- Compatible with PROFINET protocol for transparent data transmission
- Turbo Ring and Turbo Chain (recovery time < 20 ms @ 250 switches), RSTP/STP, and MSTP for network redundancy
- IGMP snooping and GMRP for filtering multicast traffic
- Port-based VLAN, IEEE 802.1Q VLAN, and GVRP to ease network planning
- QoS (IEEE 802.1p/1Q) and TOS/DiffServ to increase determinism
- Port Trunking for optimum bandwidth utilization
- RMON for efficient network monitoring and proactive capability
- SNMPv1/v2c/v3 for different levels of network management
- TACACS+, SNMPv3, IEEE 802.1X, HTTPS, and SSH to enhance network security
- Bandwidth management to prevent unpredictable network status
- Lock port function for blocking unauthorized access based on MAC address
- Automatic warning by exception through e-mail, relay output

## Specifications

### Technology

#### Standards:

IEEE 802.3 for 10BaseT  
IEEE 802.3u for 100BaseT(X) and 100BaseFX  
IEEE 802.3x for Flow Control  
IEEE 802.1D-2004 for Spanning Tree Protocol  
IEEE 802.1w for Rapid STP  
IEEE 802.1s for Multiple Spanning Tree Protocol  
IEEE 802.1Q for VLAN Tagging  
IEEE 802.1p for Class of Service  
IEEE 802.1X for Authentication  
IEEE 802.3ad for Port Trunk with LACP

#### Software Features

**Management:** IPv4/IPv6, SNMP v1/v2c/v3, LLDP, Port Mirror, DDM, RMON, DHCP Server/Client, DHCP Option 66/67/82, BootP, TFTP, SMTP, RARP, Telnet, Syslog, SNMP Inform, Flow Control, Back Pressure Flow Control

**Filter:** 802.1Q VLAN, Port-Based VLAN, GVRP, IGMP v1/v2, GMRP

**Redundancy Protocols:** STP, RSTP, MSTP, Turbo Ring v1/v2, Turbo Chain, Link Aggregation

**Security:** RADIUS, TACACS+, SSL, SSH, Port Lock, Broadcast Storm Protection (EDS-516A only)

**Time Management:** SNTP, NTP Server/Client, IEEE 1588v2 PTP (software-based)

**Industrial Protocols:** EtherNet/IP, Modbus/TCP

**MIB:** MIB-II, Ethernet-Like MIB, P-BRIDGE MIB, Q-BRIDGE MIB, Bridge MIB, RSTP MIB, RMON MIB Group 1, 2, 3, 9

#### Switch Properties

**Priority Queues:** 4

**Max. Number of VLANs:** 64

**VLAN ID Range:** VID 1 to 4094

**IGMP Groups:** 256

**MAC Table Size:** 8 K

**Packet Buffer Size:** 1 Mbit (EDS-505A/508A), 2 Mbit (EDS-516A)

#### Interface

**RJ45 Ports:** 10/100BaseT(X) auto negotiation speed, Full/Half duplex mode, and auto MDI/MDI-X connection

**Fiber Ports:** 100BaseFX ports (SC/ST connector)

**Console Port:** RS-232 (RJ45 connector)

**DIP Switches:** Turbo Ring, Master, Coupler, Reserve (EDS-505A/508A series only)

**Alarm Contact:** 2 relay outputs with current carrying capacity of 1 A @ 24 VDC

**STANTEC**  
**THIS PAGE ONLY**  
**NO EXCEPTION TAKEN**

**Digital Inputs:** 2 inputs with the same ground, but electrically isolated from the electronics.

- +13 to +30 V for state "1"
- -30 to +3 V for state "0"
- Max. input current: 8 mA

**Optical Fiber**

Fiber Cable Type	100BaseFX			
	OM1	Multi-Mode	Single-Mode (40 km)	Single-Mode (80 km)
		50/125 μm 800 MHz*km	G. 652	G. 652
Typical Distance	4 km	5 km	40 km	80 km
Wave-length	Typical (nm)	1300	1310	1550
	TX Range (nm)	1260 to 1360	1280 to 1340	1530 to 1570
	RX Range (nm)	1100 to 1600	1100 to 1600	1100 to 1600
Optical Power	TX Range (dBm)	-10 to -20	0 to -5	0 to -5
	RX Range (dBm)	-3 to -32	-3 to -34	-3 to -34
	Link Budget (dB)	12	29	29
	Dispersion Penalty (dB)	3	1	1

Note: When connecting a single-mode fiber transceiver, we recommend using an attenuator to prevent damage caused by excessive optical power.  
Note: Compute the "typical distance" of a specific fiber transceiver as follows:  
Link budget (dB) > dispersion penalty (dB) + total link loss (dB).

**Power Requirements**

- Input Voltage:** 24 VDC, redundant dual inputs
- Operating Voltage:** 12 to 45 VDC
- Input Current:** EDS-505A: 0.21 A @ 24 V
- EDS-505A-MM/SS: 0.3 A @ 24 V
- EDS-508A: 0.22A @ 24 V
- EDS-508A-MM/SS: 0.31 A @ 24 V
- EDS-516A: 0.35 A @ 24 V
- EDS-516A-MM: 0.44 A @ 24 V

- Overload Current Protection:** Present
- Connection:** 2 removable 6-contact terminal blocks
- Reverse Polarity Protection:** Present

**Physical Characteristics**

- Housing:** Metal
- IP Rating:** IP30 protection

**Dimensions**

**EDS-505A/508A Series**

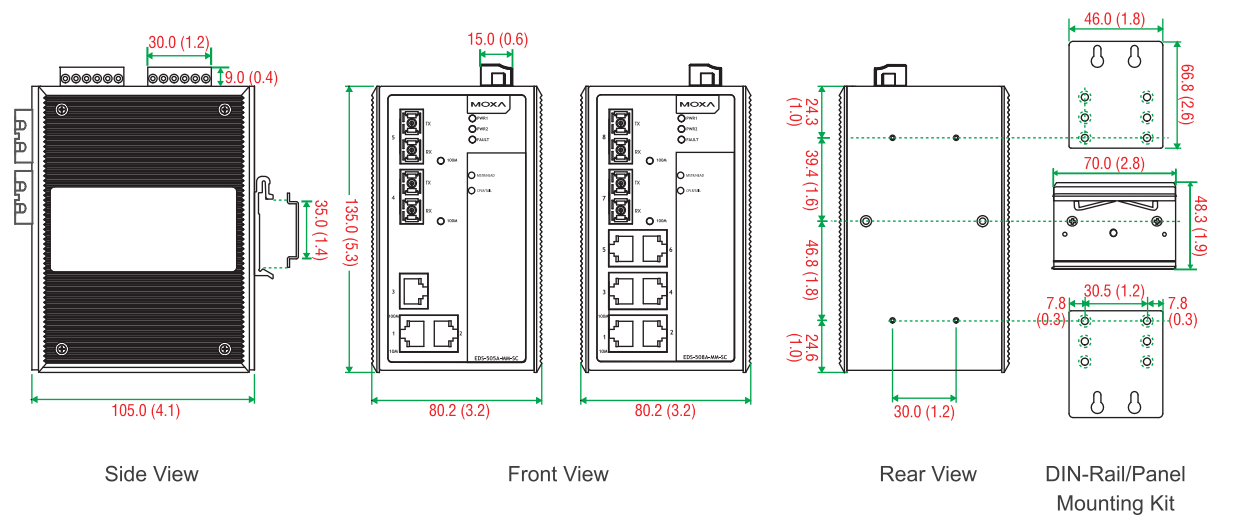

**Dimensions:**

- EDS-505A/508A Series: 80.2 x 135 x 105 mm (3.16 x 5.31 x 4.13 in)
- EDS-516A Series: 94 x 135 x 142.7 mm (3.7 x 5.31 x 5.62 in)

**Weight:**

- EDS-505A/508A Series: 1040 g (2.30 lb)
- EDS-516A Series: 1586 g (3.50 lb)

**Installation:** DIN-rail mounting, wall mounting (with optional kit)

**Environmental Limits**

**Operating Temperature:**

- Standard Models: 0 to 60°C (32 to 140°F)
- Wide Temp. Models: -40 to 75°C (-40 to 167°F)

**Storage Temperature:** -40 to 85°C (-40 to 185°F)

**Ambient Relative Humidity:** 5 to 95% (non-condensing)

**Standards and Certifications**

**Safety:** UL 508, UL 60950-1, CSA C22.2 No. 60950-1, EN 60950-1

**Hazardous Location:** UL/cUL Class 1 Division 2 Groups A/B/C/D, ATEX Zone 2 Ex nA nC IIC T4 Gc

**EMC:** EN 55032/24

**EMI:** CISPR 32, FCC Part 15B Class A

**EMS:** IEC 61000-4-2 ESD: Contact: 6 kV; Air: 8 kV

IEC 61000-4-3 RS: 80 MHz to 1 GHz: 10 V/m

IEC 61000-4-4 EFT: Power: 1 kV; Signal: 0.5 kV

IEC 61000-4-5 Surge: Power: 2 kV; Signal: 1 kV

IEC 61000-4-6 CS: 10 V

IEC 61000-4-8

**Marine:** DNV, GL

**Shock:** IEC 60068-2-27

**Freefall:** IEC 60068-2-32

**Vibration:** IEC 60068-2-6

Note: Please check Moxa's website for the most up-to-date certification status.

**MTBF (mean time between failures)**

**Time:**

EDS-505A Series: 352,000 hrs

EDS-508A Series: 339,000 hrs

EDS-516A Series: 247,000 hrs

**Standard:** Telcordia (Bellcore), GB

**Warranty**

**Warranty Period:** 5 years

**Details:** See [www.moxa.com/warranty](http://www.moxa.com/warranty)

**STANTEC**  
**THIS PAGE ONLY**  
**NO EXCEPTION TAKEN**

**Dimensions**

**EDS-516A Series**

Unit: mm (inch)

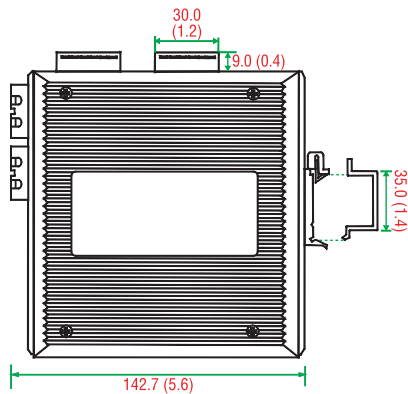

Side View

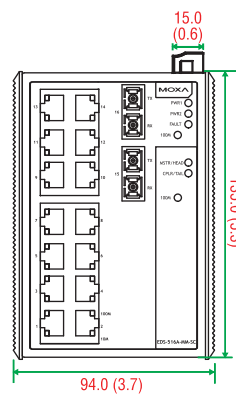

Front View

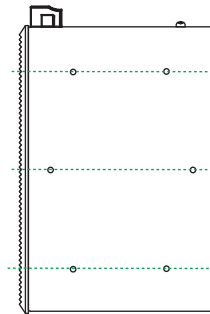

Rear View

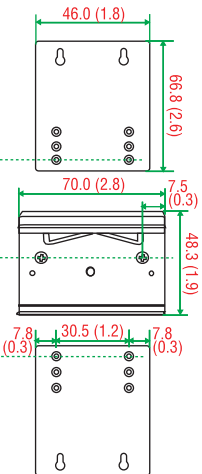

DIN-Rail/Panel-Mounting Kit

**Ordering Information**

Available Models		Port Interface				
Standard Temperature (0 to 60°C)	Wide Temperature (-40 to 75°C)	10/100BaseT(X)	100BaseFX			
			Multi-Mode, SC Connector	Multi-Mode, ST Connector	Single-Mode, SC Connector	Single-Mode, SC Connector, 80 km
<b>EDS-505A/508A Series</b>						
EDS-505A/508A	EDS-505A/508A-T	5/8	-	-	-	-
EDS-505A/508A-MM-SC	EDS-505A/508A-MM-SC-T	3/6	2	-	-	-
EDS-505A/508A-MM-ST	EDS-505A/508A-MM-ST-T	3/6	-	2	-	-
EDS-505A/508A-SS-SC	EDS-505A/508A-SS-SC-T	3/6	-	-	2	-
EDS-508A-SS-SC-80	-	6	-	-	-	2
<b>EDS-516A Series</b>						
EDS-516A	EDS-516A-T	16	-	-	-	-
EDS-516A-MM-SC	EDS-516A-MM-SC-T	14	2	-	-	-
EDS-516A-MM-ST	EDS-516A-MM-ST-T	14	-	2	-	-

**Optional Accessories** (can be purchased separately)

**MXview:** Moxa industrial network management software with 50, 100, 250, 500, 1000, or 2000 nodes

**EDS-SNMP OPC Server Pro:** OPC server software that works with all SNMP devices

**ABC-01:** Configuration backup and restoration tool for managed Ethernet switches, 0 to 60°C operating temperature

**DR-4524/75-24/120-24:** 45/75/120 W DIN-rail 24 VDC power supplies

**MDR-40-24/60-24:** 40/60 W DIN-rail 24 VDC power supplies, -20 to 70°C operating temperature

**RK-4U:** 4U-high 19-inch rack-mounting kit

**WK-46:** Wall-mounting kit, 2 plates with 8 screws

**Package Checklist**

- EDS-505A or EDS-508A or EDS-516A switch
- Serial Cable: CN20070
- Protective caps for unused ports
- Documentation and software CD
- Hardware installation guide (printed)
- Warranty card

**STANTEC**  
**THIS PAGE ONLY**  
**NO EXCEPTION TAKEN**

SUBMITTAL  
Do Not Use  
For Installation

This Page was left blank intentionally.