



Indirect Potable Reuse, a Potential New Water Supply for Northern Nevada?

*John Enloe, Operational Strategies Manager
Truckee Meadows Water Authority*

June 2, 2015



Potable Reuse is a current National Topic

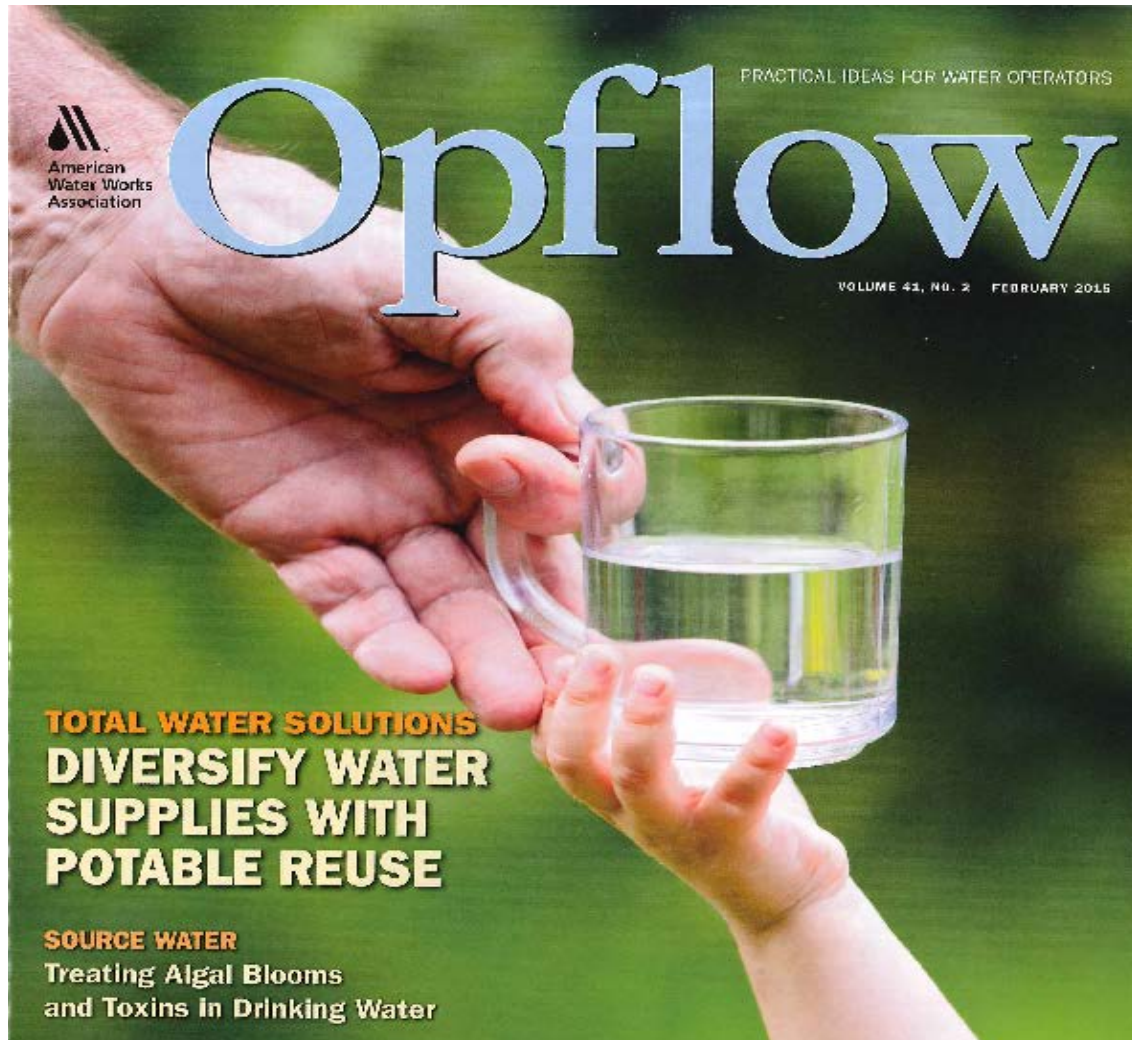



What is Potable Reuse?

- Indirect Potable Reuse – after extensive treatment, water stored in an environmental buffer (lake or aquifer) before entering the drinking water supply.
- Direct Potable Reuse – eliminates the environmental buffer, more robust and redundant treatment.
- De Facto Potable Reuse – a community downstream of another withdraws its drinking water from the surface water containing the discharge from the upstream community.





National / International Potable Reuse Projects

- Reverse Osmosis (RO)
 - Singapore, Scottsdale, AZ
- RO-UV-AOP or Full Advanced Treatment (FAT)
 - Orange County (GWRS) and nearby cities, CA
 - Silicon Valley Advanced Water Purification Center, CA (Demonstration Project)
- Ozone-Biologically Active Carbon Filtration (O3-BAC)
 - El Paso, TX
 - Reno, NV (pilot test)
- Las Vegas / Lake Mead**





Regional Benefits of Indirect Potable Reuse – Why should we consider it?

- Efficient use of limited resource
- Creates an additional beneficial use of recycled water = a new, reliable water supply
- Replenishment of over-drafted aquifers
- Drought / climate change uncertainty





The North Valleys Initiative: Detailed Evaluation of 3 Disposal Options

- Expanded use of reclaimed water – front and backyard residential irrigation
- Export treated effluent out of the basin – discharge to Long Valley Creek, CA
- Indirect Potable Reuse using groundwater replenishment





Expanded Use of Reclaimed Water

- Residential reuse required to dispose of large effluent volume
- Serrano field trip, El Dorado Hills, CA
- Workshop in Reno with NDEP and WCDHD regulators
- Detailed evaluation of dual water system requirements and costs





Conclusions

- Residential reuse was the least desirable option
- Regulators did not want to go there, no regulatory authority
- Monitoring, enforcement, inspection, public contact
- Cost and O&M of dual water system
- Winter storage, 7-8 month irrigation season





Export Treated Effluent Out of the Basin

- Discharge in NV, flows to Long Valley Creek, CA
- Expensive, but could be permitted
- Not politically acceptable at the time
- \$100M spent on new water supply, use it once, then give it to California?





Indirect Potable Reuse – Groundwater Replenishment Concept

- Reno 18 month pilot treatment study
- Extensive pilot testing of MF-O3-BAC process
- No TDS issue (<450 mg/l), don't need RO
- Brine disposal challenge
- Degrade vs. concentrate contaminants





Orange County RO-UV-AOP Full Advanced Treatment (FAT) Process Train

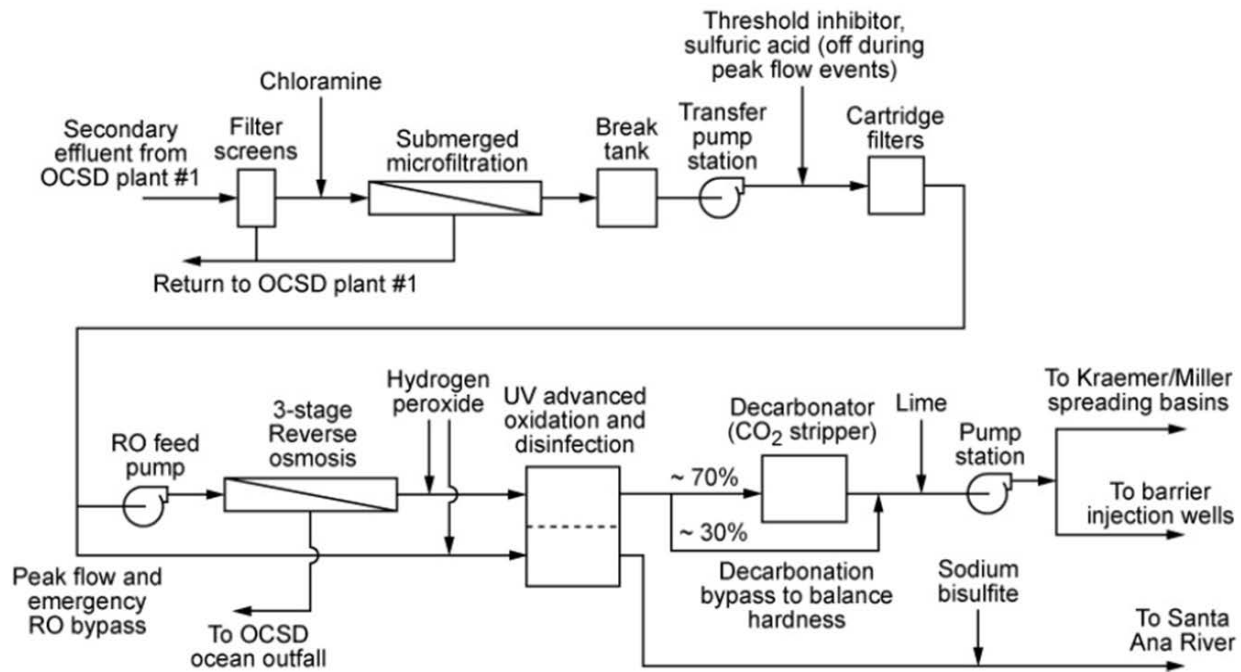

Adapted from OCWD



Ozone-BAC: Alternative to RO

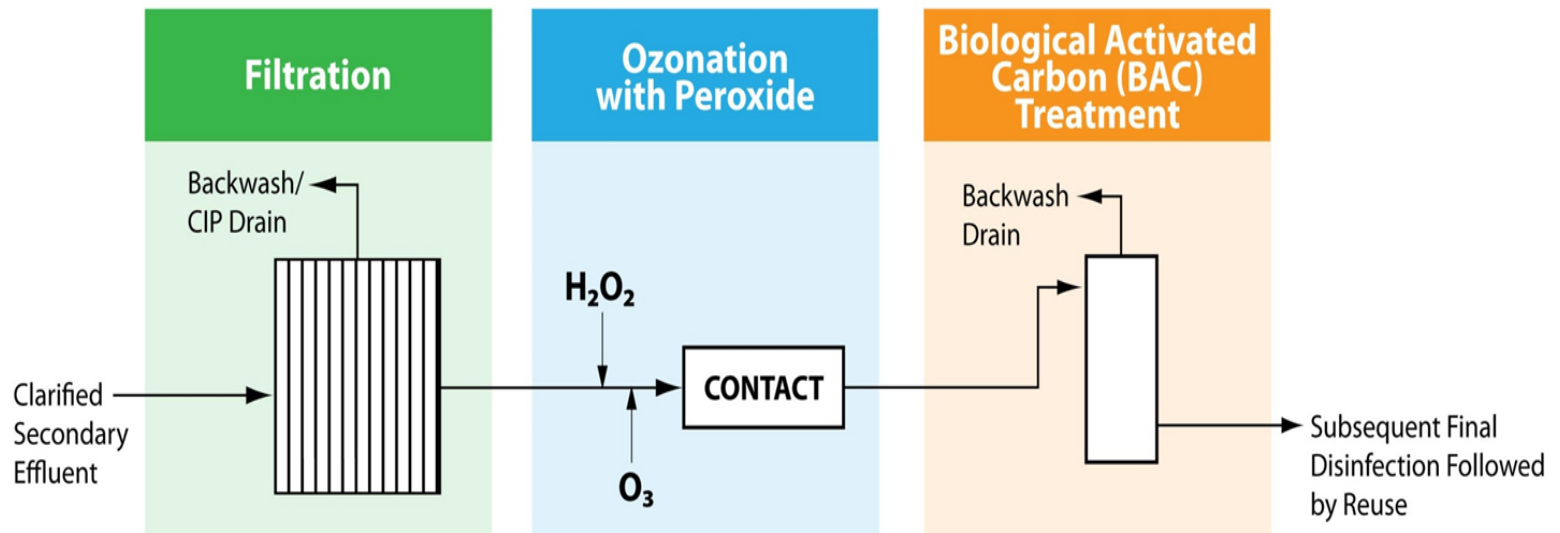

- Most refractory organics destroyed, not concentrated in brine stream
- No brine stream generated needing treatment and/or disposal
- Lower capital cost
- Lower energy utilization and O&M cost

Pilot Testing Sampling Program

- 3 Main sampling events, clean sampling techniques
- 490 Contaminants
- Sampling and quantification of contaminants after each treatment process





MF-O3-BAC Effluent Water Quality

Group	Constituents	Units	Secondary Clarifier Effluent	Membrane Filter Effluent	Ozonation Effluent	BAC Effluent	Blank
Hormones	Estradiol	ng/l	5.9	3.4	1.9	1.8	2
	Estrone	ng/l	65	11.9	0.52	0.5	0.5
Pharmaceuticals	Gemfibrozil	ng/l	45.7	35.3	0.2	0.2	< 0.080
	Ibuprofen	ng/l	4.4	6.4	< 0.39	< 0.39	< 0.39
	Naproxen	ng/l	20.5	17.9	< 0.25	< 0.25	< 0.25
	Triclosan	ng/l	54.7	2.2	< 1.2	< 1.2	< 1.2
	Diazepam	ng/l	2.7	2.8	0.18	< 0.14	< 0.14
	Fluoxetine	ng/l	3.2	2.4	2	< 0.080	< 0.080
	Primidone	ng/l	140	129	4.6	< 0.6	< 0.6
	Trimethoprim	ng/l	270	130	< 2.4	< 2.4	< 2.4
	Atorvastatin	ng/l	14.3	5.5	< 0.11	< 0.11	< 0.11
	Azithromycin	ng/l	323	102	< 22	< 22	< 22
	Caffeine	ug/l	25	10.8	< 0.042	< 0.042	< 0.042
	Ciprofloxacin	ng/l	363	247	< 14	< 14	< 14
	Cotinine	ng/l	54.5	20.5	14	2.3	0.49
	Meprobamate	ng/l	385	343	43.5	3	< 1
	Sulfamethoxazole	ng/l	930	833	6.0	< 0.25	< 0.25
	Methadone	ng/l	65.3	33	0.3	0.13	< 0.4
	Atenolol	ng/l	953	890	10.6	< 1	< 1
	Carbamazepine	ng/l	258	247	0.98	0.8	0.8
	Dilantin	ng/l	253	150	3.1	< 1	< 1
	Diclofenac	ng/l	96	109	< 0.5	< 0.5	< 0.5
	Amoxicillin	ng/l	1633	1020	0.74	ND	ND
	Phenytoin	ng/l	390	343	3.9	ND	ND
	Salicylic Acid	ng/l	25	32.67	28	20.67	48.67
Flame Retardants	TCEP	ng/l	620	545	445	< 3.4	< 3.4
	TCPP	ng/l	2100	2400	1400	< 2.7	< 2.7
	TDCPP	ng/l	633	623	627	0.695	3.23
Industrial EDCs	Bisphenol A	ng/l	18	22	< 0.27	< 0.27	2200
	Octylphenol	ng/l	31	< 25	< 25	< 25	< 25
	Nonylphenol monoethoxylate	ug/l	1.1	0.87	< 0.87	< 0.87	< 0.87
Organics	DEET	ng/l	115	125	2.56	< 0.60	1.2
	Musk Ketone	ng/l	47	38	< 25	< 25	< 25
	BHA	ng/l	76	42	< 1	< 1	< 1
	Atrazine	ng/l	1.3	1.5	0.5	< 0.25	< 0.25
	Benzophenone	ng/l	203	173	< 50	< 50	< 50
	1,4-Dioxane	ug/l	1.53	1.5	0.3	0.4	< 0.13
Ozone Byproducts	Formaldehyde	ug/l	9.2	9.8	133.3	5.8	2.4
	Acetaldehyde	ug/l	3.5	2.1	31.0	< 1	< 1
	Ethyl Glyoxal	ug/l	3.3	3.1	41.3	3.9	< 1.1
	Methyl Glyoxal	ug/l	3.3	3.4	27.0	3.7	< 0.5
	Propanal	ug/l	<0.7	<0.7	3.5	< 0.7	< 0.7
	NDMA	ng/l	1	0.9	7.9	< 0.28	0.385





Findings from Pilot Treatment Study

- MF-O3-BAC process is technically feasible, some process design questions remain
- Regulators were more supportive than residential reuse, but:
 - No statewide regulations, need development
 - CA regulations not necessarily appropriate for NV
 - Need a public dialogue / process



Potable Reuse Project Capital Cost (per MGD)

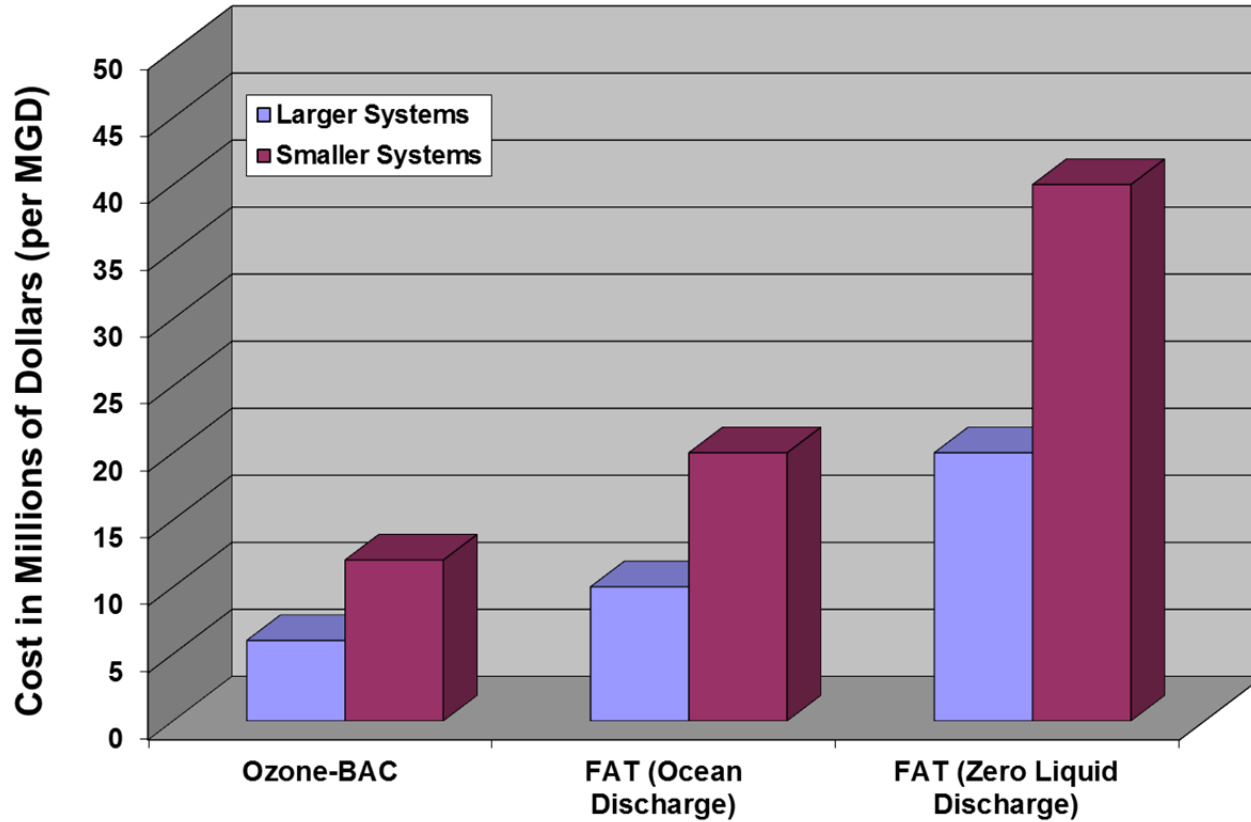



2015 Nevada Reuse Steering Committee

- Conduct a comprehensive review of Nevada's reuse program for treated effluent
- Provide strategic direction for future reuse
 - Snowmaking, water features, industrial processes, food crops, potable reuse, others...
 - Innovative process technologies
- For potable reuse, local communities will have to take on the PR issues





Public Perception Concerns

- Demonstrate the value of reclaimed water
- Define the overall water resource benefits to the region
- Hold a community dialogue about investing in reclaimed water
- Weigh the concerns and potential benefits, is IPR feasible for the Truckee Meadows?
- Develop a plan and agreements for addressing public health, water quality and regulatory issues
- Sponsoring/ lead agency for the initial project

